

# County of El Dorado Drainage Manual



Adopted: March 14, 1995  
Resolution No.: 67-95

Adopted: September 22, 2020  
Resolution No: 140-2020

## ***Introduction***

Urbanization and a focus on drainage priorities in the county of El Dorado provided an impetus for the development of a criteria document to address the procedures of hydrology and hydraulics required for the analysis and design of drainage facilities within the County.

The Board of Supervisors directed the Department of Transportation to develop a Hydrology and Hydraulics Manual with an objective to furnish the user with computational techniques and criteria required for the performance of hydrologic and hydraulic analysis and design of drainage facilities within the County. This manual is intended to outline procedures necessary to provide uniform methodology in the performance of the analysis and design of these facilities. It has been prepared on the basis of research, development of criteria consistent with state of the art procedures and actual design experience.

The results of the analysis and design performed in accordance with the guidelines established by this manual largely support proposed design of discretionary applications such as tentative subdivision maps and parcel maps. The latter applications are projects subject to environmental review whereby the submitted drainage analysis and design proposals will be critiqued for environmental impacts by the County of El Dorado.

## **Acknowledgements**

### **Acknowledgments for the Initial Version (1995)**

**Active Participants:** The following individuals have actively participated in the development of this manual.

David T. Ford, Ph.D., P.E. Hydrologic Consulting Engineer  
Douglas Hamilton, M.S., P.E.  
Douglas P. Boyle, Hydrologist  
Joseph W. Domenichelli, P.E., Psomas and Associates  
Ron Butler, P.E., County of El Dorado  
Robert S. Slater, P.E., County of El Dorado  
Janice Hackett, Administrative Secretary, County of El Dorado

**Review Participants:** The following individuals have participated in the development, review and critique of various aspects of this manual.

Rick Bettis, Ensign & Buckley, Consulting Engineers  
Edward J. Schmit, State Hydrologist, Natural Resources Conservation Service, USDA  
Randy Pesses, P.E., County of El Dorado

#### SAGE Flood Control Committee

Albert Hazbun, Chairman  
John Bassett  
Barbara "Bobbie" Lebeck  
Eric Cotter  
Dave Crosariol  
James C. Kimmel, Natural Resources Conservation Service, USDA  
Mick McGuire  
Craig Olson  
Web Owen  
Michael T. Robertson

### **Acknowledgments for the Updated Version (2020)**

Several people have devoted their time to editing, formatting, proofing, recreating charts, etc. Without their assistance this updated version would not have been realized. A special thanks to the following: Tracy Melton, Jess Melchor, Sarah Beal, Lindsay Tallman, Dave Spiegelberg, and Julie Millard.

## ***Preface***

The *County of El Dorado Drainage Manual (Drainage Manual)* was adopted by the County Board of Supervisors in 1995 to meet the needs of El Dorado County residents, businesses, and regulators. The intervening 25 years have brought significant population growth, residential and commercial development, and improved design and construction standards. In response, the *Drainage Manual* has undergone some revisions.

The primary goals in preparing this updated version are as follows:

- Improve the quality and accuracy of the information provided.
- Correct numerous typographical and formatting errors.
- Incorporate an interactive Table of Contents to make document navigation more user-friendly.

Specific updates to the manual include:

- Incorporation of revised runoff tables using 2007 data in Section 2. Previously, this information was maintained as a separate document from the *Drainage Manual*.
- Incorporation of Jim Goodridge's 2008 rainfall data charts and mean annual rainfall map in Section 2.
- Refreshed various charts for a more aesthetic appearance.
- Added updated reference lists in each section to identify current reference information or references omitted from the 1995 version.

No manual is ever free of errors or incapable of being improved. The Department of Transportation welcomes your comments or corrections.



## ***Climate Change***

The rainfall and hydrologic response effects of a changing climate have not been accounted for in the development of this drainage manual revision. The four Representative Concentration Pathways (RCPs), namely RCP2.6, RCP4.5, RCP6, and RCP8.5, are labeled after a possible range of radiative forcing values in the year 2100 (2.6, 4.5, 6.0, and 8.5 W/m<sup>2</sup>, respectively).

The RCPs are consistent with a wide range of possible changes in future anthropogenic (human) Greenhouse Gas (GHG) emissions, and aim to represent their atmospheric concentrations.

- RCP 2.6 assumes that global annual GHG emissions (measured in CO<sub>2</sub>-equivalents) peak between 2010 and 2020, with emissions declining substantially thereafter.
- RCP 4.5 assumes that emissions peak around 2040, and then decline.
- RCP 6 assumes emissions peak around 2080, and then decline.
- RCP 8.5 assumes emissions continue to rise throughout the 21st century.

The four model projections are in agreement that daytime and nighttime temperatures will continue to increase. For example, the RCP 8.5 scenario estimates an increase of 5°C by the end of the century. All model scenarios also indicate a downward trend in precipitation as snow and an increase in precipitation in the form of rain. Total annual precipitation is also anticipated to increase with wetter wet years and drier dry years. Climate Extreme Value Analysis (i.e. 100-year flood) has found significant upward trends in the future annual maximum of daily and hourly rainfall precipitation.

There is uncertainty with how water vapor changes from warming surface temperatures will affect wintertime atmospheric rivers (ARs) but all studies suggest significant increases in the frequencies and intensities of ARs making landfall, and projections indicate warmer temperatures and increased winter storm intensities. It is anticipated that the values for the 2, 20 and 100 year return intervals will be changing significantly though there is currently no clear guidance with how to account for this.

This statement is included to acknowledge the impact of a changing climate. This drainage manual update revision, however, does not account for projected climate change revisions. This is primarily due to a lack of standardized federal and state guidance on the modeling of future conditions or how to account for anticipated changes in rainfall and hydrologic response using the current state of knowledge on the topic.

# Contents

## **Section 1 – Definitions and General Drainage Guidelines**

|  |      |
|--|------|
| 1.1 Organization of Manual.....  | 1-2  |
| 1.2 Protection of Life and Property .....  | 1-2  |
| 1.3 Disposal of Storm Runoff .....   | 1-3  |
| 1.4 Increased Runoff.....  | 1-4  |
| 1.5 Flood Plains .....   | 1-5  |
| 1.6 Erosion and Pollution Control .....  | 1-5  |
| 1.7 Lake Tahoe Basin.....  | 1-7  |
| 1.8 Drainage Requirements .....  | 1-7  |
| 1.8.1 General Design Criteria .....  | 1-7  |
| 1.8.2 Design Criteria – Land Divisions.....  | 1-7  |
| 1.8.3 Submittal Requirements .....   | 1-14 |
| Appendix 1.1 Additional Regulatory Requirements.....   | 1-18 |
| A1.1.1 Purpose and Scope.....  | 1-18 |
| A1.1.2 Basic Drainage Law Requirements .....   | 1-18 |
| A1.1.3 General Plans .....   | 1-19 |
| A1.1.4 Subdivision Map Act.....  | 1-19 |
| A1.1.5 California Environmental Quality Act (CEQA) .....   | 1-20 |
| A1.1.6 Porter-Cologne Water Quality Control Act.....   | 1-20 |
| A1.1.7 California Fish and Wildlife Code .....   | 1-21 |
| A1.1.8 Section 404 of the National Clean Water Act .....   | 1-21 |
| A1.1.9 National Flood Insurance Program.....   | 1-22 |
| A1.1.10 Section 402 of the Clean Water Act - National Pollutant<br>Discharge Elimination System (NPDES) Program..... | 1-22 |
| Appendix 1.2 Definitions.....  | 1-24 |
| Appendix 1.3 References.....   | 1-40 |
| Appendix 1.3.1 Updated References .....  | 1-41 |

## **Section 2 – Hydrology**

|  |      |
|--|------|
| 2.1 Background.....  | 2-2  |
| 2.2 Overview .....   | 2-3  |
| 2.2.1 Analysis Steps .....                                   | 2-3  |
| 2.2.2 Appropriate Stormwater-runoff Computation Method ..... | 2-4  |
| 2.2.3 Exceptions .....                                       | 2-5  |
| 2.3 Design Precipitation .....                               | 2-5  |
| 2.3.1 Design-storm Duration.....                             | 2-6  |
| 2.3.2 Design-storm Depth.....                                | 2-7  |
| 2.3.3 Design-storm Temporal Distribution .....               | 2-9  |
| 2.4 Hydrograph Method .....                                  | 2-11 |
| 2.4.1 Runoff Volume.....                                     | 2-12 |
| 2.4.2 Runoff Hydrograph .....                                | 2-14 |
| 2.5 Peak-discharge Method .....                              | 2-18 |

|   |      |
|---|------|
| 2.6 Baseflow .....                                      | 2-23 |
| 2.7 Complex Catchment Analysis .....                    | 2-24 |
| 2.7.1 Subcatchment Delineation.....                     | 2-24 |
| 2.7.2 Streamflow Routing .....                          | 2-25 |
| 2.7.3 Water-control Measures .....                      | 2-27 |
| 2.8 Reasonableness .....                                | 2-27 |
| 2.9 Computer Programs.....                              | 2-28 |
| 2.9.1 NRCS Program TR-55.....                           | 2-28 |
| 2.9.2 USACE Program HEC-1 and HEC-HMS .....             | 2-28 |
| Appendix 2.1 References.....                            | 2-29 |
| Appendix 2.1.1 Updated References.....                  | 2-31 |
| Appendix 2.2 El Dorado County Design Rainfall Data..... | 2-32 |
| Appendix 2.3 NRCS Curve Number Tables.....              | 2-48 |
| Appendix 2.4 USGS Regional Frequency Estimates .....    | 2-55 |
| Appendix 2.5 HEC-1 Input Example .....                  | 2-56 |

### **Section 3 – Surface Drainage Design**

|  |      |
|--|------|
| 3.1 Background.....                              | 3-2  |
| 3.2 Analysis Procedures .....                    | 3-2  |
| 3.2.1 Sub-Area Runoff.....                       | 3-3  |
| 3.2.2 Street Flow Hydraulics.....                | 3-3  |
| 3.2.3 Inlet Analysis .....                       | 3-4  |
| 3.2.4 Inlet for Sump Conditions .....            | 3-6  |
| 3.2.5 Analysis Steps .....                       | 3-7  |
| 3.2.6 100-Year Peak Flow Analysis.....           | 3-8  |
| 3.3 Design Criteria .....                        | 3-9  |
| 3.3.1 Overland Flow Criteria.....                | 3-9  |
| 3.3.2 Recommended Minimum Surface Grades.....    | 3-9  |
| 3.3.3 Fencing.....                               | 3-10 |
| 3.3.4 Back of Lot Swales and Other Ditches ..... | 3-10 |
| 3.3.5 Flow on Streets.....                       | 3-10 |
| Appendix 3.1 References.....                     | 3-12 |
| Appendix 3.1.1 Updated References .....          | 3-13 |

### **Section 4 – Hydraulic Design of Closed Conduits**

|   |     |
|---|-----|
| 4.1 Background.....                               | 4-2 |
| 4.2 Analysis Procedures .....                     | 4-3 |
| 4.2.1 Classification of Closed Conduit Flow ..... | 4-3 |
| 4.2.2 Manning’s Equation .....                    | 4-3 |
| 4.2.3 Selection of Manning’s n Value .....        | 4-4 |
| 4.2.4 Uniform Flow in Circular Pipes .....        | 4-5 |
| 4.2.5 Critical Depth in Circular Pipes.....       | 4-5 |

|  |      |
|--|------|
| 4.2.6 Non-uniform Flow in Circular Pipes .....               | 4-6  |
| 4.2.7 Pressure Flow Calculations .....                       | 4-9  |
| 4.2.8 Evaluation of Minor Losses.....                        | 4-9  |
| 4.3 Closed Conduit Design Criteria.....                      | 4-9  |
| 4.3.1 Alignment.....   | 4-9  |
| 4.3.2 Hydraulic Grade Line .....                             | 4-10 |
| 4.3.3 Easements.....   | 4-10 |
| 4.3.4 Design Flow.....                                       | 4-10 |
| 4.3.5 Velocity Requirements.....                             | 4-10 |
| 4.3.6 Pipe Size .....  | 4-10 |
| 4.3.7 Manholes .....   | 4-10 |
| 4.3.8 Inlet Structures .....                                 | 4-11 |
| 4.3.9 Outlet Structures.....                                 | 4-11 |
| 4.3.10 Fencing and Protection Barriers .....                 | 4-11 |
| 4.3.11 Debris Racks .....                                    | 4-12 |
| 4.3.12 Flap Gates .....                                      | 4-12 |
| 4.3.13 Placement and Construction.....                       | 4-12 |
| 4.3.14 Subdrainage .....                                     | 4-12 |
| Appendix 4.1 References.....                                 | 4-13 |
| Appendix 4.1.1 Updated References.....                       | 4-14 |
| Appendix 4.2 Hydraulic Properties for Circular Conduits..... | 4-15 |
| Appendix 4.3 Evaluation of Minor Losses in Pipes .....       | 4-19 |

**Section 5 – Stormwater Storage Design**

|  |      |
|--|------|
| 5.1 Background.....                                    | 5-2  |
| 5.2 Types of Storage Facilities.....                   | 5-3  |
| 5.2.1 Detention Structures .....                       | 5-4  |
| 5.2.2 Retention Structures.....                        | 5-5  |
| 5.2.3 Special Facilities .....                         | 5-5  |
| 5.2.4 Regional v. On-site Impoundments .....           | 5-6  |
| 5.3 Basin (Pond) Design Requirements.....              | 5-7  |
| 5.4 Embankment Design Requirements .....               | 5-8  |
| 5.5 Spillway Design Requirements .....                 | 5-9  |
| 5.6 Outlet Work Design Requirements.....               | 5-9  |
| 5.6.1 Outlet Types .....                               | 5-9  |
| 5.6.2 Outlet Standards.....                            | 5-10 |
| 5.6.3 Trash Racks .....                                | 5-11 |
| 5.6.4 Outlet Safety.....                               | 5-12 |
| 5.7 Hydrologic and Hydraulic Analysis for Design ..... | 5-12 |
| 5.7.1 Inflow Hydrograph Computations .....             | 5-12 |
| 5.7.2 Outflow Hydrograph Computations.....             | 5-12 |
| 5.7.3 Analysis Steps .....                             | 5-15 |
| Appendix 5.1 References.....                           | 5-16 |

|   |      |
|---|------|
| Appendix 5.1.1 Updated References ..... | 5-17 |
|---|------|

**Section 6 – Hydraulic Design of Open Channels**

|   |      |
|---|------|
| 6.1 Background.....   | 6-2  |
| 6.1.1 Channel Types .....                                   | 6-2  |
| 6.1.2 Natural Channels Preferred .....                      | 6-3  |
| 6.1.3 Channel Stability.....                                | 6-3  |
| 6.2 Analysis Procedures .....                               | 6-4  |
| 6.2.1 Classification of Open Channel Flow .....             | 6-5  |
| 6.2.2 Manning’s Equation .....                              | 6-6  |
| 6.2.3 Selection of Manning’s n Value .....                  | 6-6  |
| 6.2.4 Uniform Flow .....                                    | 6-9  |
| 6.2.5 Critical Depth in Open Channels .....                 | 6-9  |
| 6.2.6 Non-uniform Flow .....                                | 6-10 |
| 6.2.7 Flow Analysis Using Hydraulic Computer Programs ..... | 6-11 |
| 6.2.8 Weir Flow.....  | 6-12 |
| 6.3 Channel Design Criteria.....                            | 6-12 |
| 6.3.1 Channel Alignment .....                               | 6-12 |
| 6.3.2 Hydraulic Grade Line .....                            | 6-13 |
| 6.3.3 Easements.....  | 6-13 |
| 6.3.4 Design Flow.....                                      | 6-13 |
| 6.3.5 Freeboard.....  | 6-13 |
| 6.3.6 Low Flow .....  | 6-15 |
| 6.3.7 Velocity Requirements.....                            | 6-15 |
| 6.3.8 Use of Concrete Pipe in Place of an Open Channel..... | 6-17 |
| 6.3.9 Typical Channel Sections .....                        | 6-17 |
| 6.3.10 Design of Unreinforced Concrete Channels .....       | 6-17 |
| 6.3.11 Design of Reinforced Concrete Channels.....          | 6-18 |
| 6.3.12 Design of Rock Slope Protection for Channels.....    | 6-18 |
| 6.4 Related Design Criteria.....                            | 6-21 |
| 6.4.1 Energy Dissipators .....                              | 6-21 |
| 6.4.2 Fencing.....  | 6-22 |
| Appendix 6.1 References.....                                | 6-23 |
| Appendix 6.1.1 Updated References.....                      | 6-24 |
| Appendix 6.2 Fencing Plan.....                              | 6-25 |

**Section 7 – Hydraulic Design of Culverts**

|  |     |
|--|-----|
| 7.1 Background.....                            | 7-2 |
| 7.1.1 Culvert Shapes .....                     | 7-2 |
| 7.1.2 Culvert Materials.....                   | 7-3 |
| 7.1.3 Culvert Inlet Types.....                 | 7-3 |
| 7.2 Analysis Procedures .....                  | 7-3 |
| 7.2.1 Classification of Flow in Culverts ..... | 7-3 |

|  |      |
|--|------|
| 7.2.2 Types of Inlet Control .....                           | 7-4  |
| 7.2.3 Types of Outlet Control.....                           | 7-6  |
| 7.2.4 Analysis Procedure.....                                | 7-8  |
| 7.2.5 Nomograph Design Chart Procedure .....                 | 7-8  |
| 7.2.6 Computer Programs for Culvert Analysis .....           | 7-10 |
| 7.2.7 Analysis of Grates on Culvert Openings.....            | 7-11 |
| 7.3 Culvert Design Criteria.....                             | 7-11 |
| 7.3.1 Water Surface Elevation .....                          | 7-11 |
| 7.3.2 Culvert Material .....                                 | 7-11 |
| 7.3.3 Erosion Protection .....                               | 7-12 |
| Appendix 7.1 References.....                                 | 7-13 |
| Appendix 7.1.1 Updated References.....                       | 7-14 |
| Appendix 7.2 Culvert Hydraulics Nomograph Design Charts..... | 7-15 |

*This page intentionally left blank.*

**Section  
1**

**Definitions and General Drainage Guidelines**

**Contents of this section**

- 1.1 Organization of Manual..... 1-2
- 1.2 Protection of Life and Property ..... 1-2
- 1.3 Disposal of Storm Runoff ..... 1-3
- 1.4 Increased Runoff..... 1-4
- 1.5 Flood Plains ..... 1-5
- 1.6 Erosion and Pollution Control ..... 1-5
- 1.7 Lake Tahoe Basin ..... 1-7
- 1.8 Drainage Requirements ..... 1-7
  - 1.8.1 General Design Criteria ..... 1-7
  - 1.8.2 Design Criteria – Land Divisions ..... 1-7
  - 1.8.3 Submittal Requirements..... 1-14
  
- Appendix 1.1 Additional Regulatory Requirements..... 1-18
  - A1.1.1 Purpose and Scope ..... 1-18
  - A1.1.2 Basic Drainage Law Requirements ..... 1-18
  - A1.1.3 General Plans..... 1-19
  - A1.1.4 Subdivision Map Act ..... 1-19
  - A1.1.5 California Environmental Quality Act (CEQA)..... 1-20
  - A1.1.6 Porter-Cologne Water Quality Control Act..... 1-20
  - A1.1.7 California Fish and Wildlife Code..... 1-21
  - A1.1.8 Section 404 of the National Clean Water Act ..... 1-21
  - A1.1.9 National Flood Insurance Program ..... 1-22
  - A1.1.10 Section 402 of the Clean Water Act - National Pollutant Discharge Elimination System (NPDES) Program ..... 1-22
  
- Appendix 1.2 Definitions ..... 1-24
- Appendix 1.3 References..... 1-40
  - Appendix 1.3.1 Updated References ..... 1-41



## **1.1 Organization of Manual**

This manual is organized into seven sections as follows:

- *Section 1 – Definitions and General Drainage Guidelines*  
Section 1 outlines basic criteria required for drainage analysis, design and submittals.
- *Section 2 – Hydrology*  
Section 2 presents techniques and criteria for determining runoff hydrology.
- *Section 3 – Surface Drainage Design*  
Section 3 discusses the analysis procedures and design criteria for surface drainage improvements.
- *Section 4 – Hydraulic Design of Closed Conduits*  
Section 4 outlines criteria and analytical procedures for closed conduit drainage systems.
- *Section 5 – Stormwater Storage Design*  
Section 5 defines storage design requirements and provides guidance for planning analyzing structures.
- *Section 6 – Hydraulics of Open Channels*  
Section 6 discusses channel types and specific criteria and issues to be considered in the design of such channels.
- *Section 7 – Hydraulic Design of Culverts*  
Section 7 discusses the criteria and analytical procedures of culvert design.

This manual also references several source materials which consider appropriate procedures applicable to the analysis and design of civil drainage facilities. Users are directed to the references as necessary to adequately investigate the details of a particular analysis or design. El Dorado County expects that the users understand that the procedures outlined in this manual are not intended as a substitute for sound engineering practice.

## **1.2 Protection of Life and Property**

The provision of adequate drainage is necessary to preserve and promote the general health, welfare and economic well-being of the public. Drainage is a regional feature that affects all parcels of property. The

responsibility for stormwater management is shared by governmental jurisdictions and all property owners.

Implementation of measures which will lessen the exposure of the public, property and infrastructure to losses due to flooding, improve the long-range land management and use of flood-prone areas, and inhibit, to the maximum extent feasible, incompatible development in such areas should be considered when planning and designing new drainage facilities or improvements to existing drainage facilities.

All habitable structures and other improvements subject to potential loss of life or property when inundated by flood waters shall be protected from damage pursuant to the requirements set forth in the *County of El Dorado Grading, Erosion and Sediment Control Ordinance (2010<sup>1</sup>)* also known as the *Grading Ordinance*. Drainage facilities shall be planned and designed to protect life and property pursuant to applicable provisions included in this document, the *County of El Dorado Design and Improvement Standards Manual (1990)* also known as the *DISM*, and the *Uniform Building Code of the County of El Dorado (2010)*.

### **1.3 Disposal of Storm Runoff**

The planning and design of drainage systems within El Dorado County shall take into consideration any potential downstream impacts including those to property, flow regimes, water quality or riparian and wetlands areas. Provisions mitigating potential impacts shall be included as a part of the drainage analysis for the proposed project.

Planning and design of drainage facilities shall not be based on the premise that drainage problems can be transferred from one location to another except when the transfer is part of a regional solution to flood problems. A proposed development shall not create increased runoff to downstream property through diversion of flows which had previously drained to another area without the implementation of adequate mitigation measures.

Diversion into non-tributary watercourses is discouraged. Diversion of natural runoff or blocking of existing drainage conveyances shall not be permitted without adequate provisions and mitigation. Modification of runoff from unconcentrated flow to concentrated flow associated with proposed downstream disposal shall be evaluated and appropriate mitigation implemented, such as providing sheet flow for drainage or the implementation of erosion control provisions.

---

<sup>1</sup> The *Grading, Erosion, and Sediment Control Ordinance* No. 3983 of 1988 was updated to No. 4719 in 2007 and to No. 4949 in 2010. See Appendix 5.1.1 for updated references.

#### **1.4 Increased Runoff**

Increases in storm runoff from upstream properties resulting from development or other improvements is discouraged in El Dorado County. Improvements which propose to increase stormwater runoff from an upstream property shall be evaluated to determine if downstream conveyance facilities can accept and convey the runoff increases.

In addition, the *El Dorado County Stormwater Quality Ordinance No. 5022* (2015) and the California State Water Resources Control Board's (SWRCB) Municipal Separate Storm Sewer Systems (MS4) Permits require water quality treatment, retention or detention, evapotranspiration, or capture and reuse of stormwater generated from newly created impervious surfaces based on specified storm events for some projects. Compliance with the *Stormwater Ordinance* and MS4 Permit provisions will most likely have an effect on the watershed response, aside from these requirements. Design of drainage/stormwater conveyance systems must consider the requirements of both water quality requirements and the *Drainage Manual* to be effective. If pre- and post-construction conditions are assessed and evaluated in the earliest planning stages, projects applicable to water quality and *Drainage Manual* requirements can typically design facilities that successfully address both water quality and volume requirements.

If downstream facilities do not meet the criteria stated above, a detailed analysis shall be made to include impacts and mitigation to all downstream facilities to show that the downstream existing facilities can adequately accept the increased flows. This analysis shall include conveyances to the confluence of the nearest master planned, regional or previously designed system or until the impacts are determined to be less than significant. The detailed analysis must show that land of downstream properties is not lost due to increased flood plain limits, there is no increase in erosion, there is no net loss of storage available to attenuate peak flows, and the capacity of the downstream facilities are such that they can accommodate the increased flow from the maximum development possible for the entire upstream catchment. The maximum development possible shall be based on the current *El Dorado County General Plan Land Use Element (2018)*.

When downstream facilities are unable to adequately accommodate increases in stormwater runoff, appropriate mitigation measures shall be implemented into the analysis and design. Implementation of detention or retention facilities on-site to attenuate peak runoff to a level which does not impact downstream facilities is acceptable in El Dorado County. Requirements for mitigation of regional flooding problems may necessitate reservation of capacity of these conveyance facilities by the County of El

Dorado. Determination of regional impacts will be considered on a case by case basis.

### **1.5 Flood Plains**

Flood plain requirements must include the definition of the natural easement boundaries necessary for intermittent occupancy by runoff waters. Encroachment upon this easement by development can adversely affect upstream and downstream flooding occurrences during periods of high runoff.

Land development shall be evaluated for impacts to flood plains both onsite and offsite. Measures shall be implemented which will lessen the exposure of property and facilities to flood losses and inhibit incompatible development in flood-prone areas. Flood plain limits shall be delimited along all significant watercourses within the proposed development. Flood plain boundaries shall be shown on preliminary and final subdivision maps. The area inundated should be indicated as a flow easement. Flood plain designations should account for future development within the catchment.

Limits shall be established from applicable Federal Emergency Management Agency (FEMA) studies, U.S. Army Corps of Engineers (USACE) Flood Plain Information Studies, U.S. Geological Survey (USGS) Flood Plain Maps, regional flood studies prepared by private consulting engineers or other appropriate studies.

Proposed development within a flood plain shall have also met all requirements and obtained all necessary approvals from jurisdictional agencies independent of the County of El Dorado and the requirements set forth in this document prior to improvement plan approval. If no requirements exist, documentation shall be provided stating that an investigation was made and requirements do not exist.

### **1.6 Erosion and Pollution Control**

Storm runoff can transport pollutants which can degrade the quality of surface waters. The water quality parameters of concern include, but are not limited to, total suspended solids, oxygen demand, nutrients, trace metals, oil and grease, bacteria, elevated temperatures, pesticides and herbicides. Hydrologic changes can occur when natural lands are developed to support land use needs. Pollutants can occur in higher concentrations in post-development conditions resulting from surface runoff volume increases and evapotranspiration and infiltration decreases.

Additionally, erosion resulting from development can cause an increase in the sources of sediment and other types of water pollution.

Storm Water Management Plans (SWMPs) and MS4 Permit requirements are used as a guide to implement Best Management Practices (BMPs) designed to reduce the discharge of pollutants to the maximum extent practicable with an objective of protecting receiving water quality. BMPs are comprised of scheduling, prohibitions of practices, maintenance procedures, and other management practices to prevent or reduce the discharge of pollutants and protect beneficial uses. Beneficial uses can include drinking water supply, body contact recreation, fishery and wildlife protection and groundwater replenishment.

The *Grading Ordinance* provides for regulation of storm water pollution resulting from development when ground disturbing activities are occurring on private lands. Requirements for erosion and sediment control measures for proposed improvements are outlined in the *DISM*. Guidelines identified in this manual are intended to supplement provisions outlined by specific County of El Dorado ordinances and prescriptive standards as defined in the *DISM*. Additionally, County of El Dorado endorses the use of applicable procedures recommended in the latest version of the following documents:

- Combined El Dorado County Resource Conservation District and El Dorado County Department of Transportation Erosion Control Requirements and Specification, July 2006
- High Sierra Resource Conservation and Development Council, 1991: *Erosion & Sediment Control Guidelines for Developing Areas of the Sierra Foothills and Mountains*
- Tahoe Regional Planning Agency: *Handbook of Best Management Practices*<sup>2</sup>
- California Stormwater Quality Association: *California Storm Water Best Management Practice Handbooks*<sup>3</sup>

---

<sup>2</sup> The *Handbook of Best Management Practices* was updated in 2014. See Appendix 1.3.1 for updated references.

<sup>3</sup> The *California Storm Water Quality Association (CASQA) Best Management Practice Handbooks* were updated in 2003. See Appendix 1.3.1 for updated references. CASQA was formerly known as the California Storm Water Quality Task Force.

## **1.7 Lake Tahoe Basin**

Surface water runoff within the tributary area of Lake Tahoe is subject to specific water quality standards and objectives unique to the Lake Tahoe Basin. Jurisdictional requirements are pursuant to regulations, standards and objectives imposed by the Lahontan Regional Water Quality Control Board and the Tahoe Regional Planning Agency.

All proponents of projects under the above jurisdictional authority must submit plans for drainage facilities to the appropriate permit-issuing authorities. Planning criteria and procedures to calculate stormwater and snowmelt flows and to design drainage facilities shall be subject to approval of the permit-issuing authorities.

## **1.8 Drainage Requirements**

### ***1.8.1 General Design Criteria***

The information presented in this manual is intended to provide consistent, specific criteria and guidelines regarding the design of storm drainage facilities and the management of stormwater in El Dorado County. Additional drainage criteria and design requirements are included in the *DISM* and in the *Grading Ordinance*. Storm drainage planning and design in El Dorado County shall adhere to the criteria presented in this document, the *DISM*, the *Grading Ordinance*, and current water quality requirements. Submittals will be reviewed and evaluated against the criteria outlined in these documents.

### ***1.8.2 Design Criteria – Land Divisions***

- ***General Requirements***

Subdivisions shall be designed to receive surface water, stream water, and flood water emanating from outside its boundaries and from within and passing such water through and off the subdivision without injury to improvements, buildings or building sites and without adversely impacting or exceeding the capacity of existing downstream drainage facilities. Surface waters shall be discharged into the natural watercourse to which they would normally drain. If surface waters are gathered, they must be conveyed under control to a water course. Design of drainage facilities shall be such that they will accommodate the ultimate development within the drainage area with minimum modification to building setback areas around wetlands (i.e., marsh, springs and streams).

- *Design of Drainage Facilities – Hydrologic Design*

Flood estimation used for the design of drainage facilities can be based upon either historical, observed flood data or from data obtained through statistical analysis. Determination of critical events must be made and the probability of recurrence must be analyzed. Acceptable levels of risk must then be established and then the design of stormwater facilities can be based upon the risk (cost) of the flow exceeding a selected design. (Water Environment Federation/American Society of Civil Engineers or WEF/ASCE, 1992).

There is confusion about the meaning and application of the criteria related to drainage design. For example, the “100-year runoff event” is the event that has probability of occurrence of 0.01 in any given year. It is often taken to mean that the event will occur only once in one hundred years, which although true on the average, may not be true for a particular 100-year period (WEF/ASCE, 1992).

Fortunately, the density of precipitation gauges in El Dorado County is sufficient to permit fitting a statistical model of precipitation depths, from which storms of specified return period can be predicted. From these storms, discharge can be estimated with a rainfall-runoff-routing model. If the median or average values of all model parameters are used, the return period of the discharge computed from precipitation should equal approximately the return period of the precipitation (Pilgrim and Cordery, 1975). This is the assumption which the County of El Dorado has adopted to determine acceptable levels of risk in the design of drainage facilities.

The following defines the levels of risk and protection for drainage facilities in El Dorado County.

1. Those watercourses set forth in master drainage plans for specific catchments within El Dorado County shall be designed and constructed not to exceed the quantities of water indicated in such master drainage plans when said plans are adopted. All other watercourses and drainage ways shall be designed by a civil engineer in accordance with the criteria described herein.
2. Drainage facilities for areas greater than 100 acres shall be designed to safely convey the storm runoff from an event with an average recurrence interval of 100 years. All available headwater depth of the culvert may be utilized for these facilities. Flooding effects from back water shall be analyzed when available headwater depth is incorporated into the design.

Drainage facilities for areas less than 100 acres shall be designed to safely convey the storm runoff from an event with an average recurrence interval of 10 years without the headwater depth exceeding the culvert barrel height. Exceptions will be considered on a case by case basis when upstream ponding is required for the attenuation of flood peaks.

3. The use of natural channels for the collection and conveyance of storm water runoff is preferred in El Dorado County. Note: Water quality treatment may be required prior to the discharge of stormwater into a natural channel. The many advantages of natural channels include the following:
  - *Preservation of riparian habitat.*
  - *Water quality enhancement.*
  - *Preservation of flood plain storage areas.*
  - *Energy dissipation due to vegetation, irregular alignments and sections.*
  - *Passive recreation uses.*
  - *Aesthetic qualities consistent with the rural character of El Dorado County.*

Natural channels may be used for the conveyance of storm runoff when the following conditions are satisfied:

- a. The natural drainage ways and other courses shall contain sufficient capacity to safely convey the storm runoff from an event with an average recurrence interval of 100 years.
- b. The natural waterways shall have historically existed in a reasonably stable condition.
- c. It can be shown that erosion is not likely to occur as a result of the land improvements. Channel stability is discussed in Section 6 – Hydraulic Design of Open Channels of this manual.
- d. Considerations are given to the natural floodway and open space requirements of the conveyance facility. Channels and adjacent land areas shall be reserved to provide an unobstructed area for the passage of the 100-year runoff event while providing for the appropriate use of adjacent lands based on knowledgeable awareness



of flood hazards. Where appropriate, floodplain and open space criteria shall comply with FEMA standards and the 100-year flood plain shall be designated.

Natural channels shall be capable of conveying runoff without increased erosion, widening and meandering of the channel alignment due to increased runoff from development.

Improvements to natural channels which provide additional capacity and/or stability erosion may be necessary when these criteria cannot be satisfied. Channel improvements shall adhere to the guidelines set forth in Section 6 – Hydraulic Design of Open Channels of this manual.

4. Design flows shall be computed by use of the methods prescribed in Section 2 – Hydrology of this manual.

- *Design of Drainage Facilities – Hydraulic Design*

1. The depth of flow or ponding shall not exceed a level which would cause inundation of building sites. One foot of freeboard shall be maintained between the building finished floor elevation and the water surface elevation resulting from a storm runoff event with an average recurrence interval of 100 years.
2. The depth of flow or ponding shall not exceed a level which would cause inundation of areas required for on-site sewage disposal systems. Requirements for the planning and design of on-site sewage disposal systems are outlined in the *County of El Dorado Onsite Wastewater Treatment Systems Ordinance (OWTS)*, also known as the *County of El Dorado Septic Ordinance (2018)*.

Inundation of sanitary sewage manholes by stormwater from stormwater conveyance facilities shall be avoided. In cases when inundation of sanitary sewage manholes is unavoidable, approval from the appropriate jurisdictional agency will be required and the manhole shall be sealed sufficient as to not allow stormwater to enter the structure.

3. Roadside ditches are permitted in El Dorado County provided the ditches are designed to carry runoff from the road surface and adjacent tributary lands without damage to the roadway or adjacent property. Roadside ditches required to transport storm runoff that has been gathered and conveyed to the roadside in channels or conduits is discouraged; however, will be reviewed on a case by case basis where it can be demonstrated that the activity will not create inundation of

traffic lanes or additional maintenance requirements. Maintenance can be required due to the deterioration of roadside drainage ditches caused by stormwater runoff. Deterioration may be due to scour from high velocities, sedimentation at low velocities or ponded water. The depth and velocity of flow in roadside ditches shall be analyzed to determine the requirements for scour prevention and other erosion measures, maintenance, prevention of ponding, frequency of cross culverts and right of way requirements. Further guidance can be found in "Introduction to Highway Hydraulics," *Hydraulic Design Series No. 4 (HDS-4)*, published by FHWA, 2008.

Permissible velocities are presented in Table 6.3.1 of this manual. Where practical, the velocities shown in Table 6.3.1 shall be considered as maximum allowable for roadside ditches and open channels. Instances in which velocities are exceeded, the design assumptions shall be justified by the design engineer and shall be reviewed and are subject to approval by El Dorado County on a case by case basis.

4. In general, the placement of new roadways in locations previously occupied by drainage ways is discouraged in El Dorado County. For major land divisions, if large drainage ways must be located within the road rights of way, the water shall be carried underground in closed conduit. Special consideration of the above criteria will be considered for rural locations on a case by case basis when mitigating circumstances can be demonstrated.
5. Drainage ways shall not block reasonable access to lots. Reasonable access is defined as permitting a driveway to be constructed utilizing an eighteen inch diameter pipe or smaller.
6. Storm runoff ponded on road surfaces resulting from depressed areas caused by grade changes or the crown slope of intersecting roads has a substantial effect on traffic safety. Problems include depths of ponding higher than the adjacent curb, ponding which remains on the roadway for long periods of time and vehicles entering ponded areas at high rates of speed. Depressed areas that create ponding which encroach into the traveled land will not be allowed in El Dorado County.
7. Depressed areas that create ponding due to site grading will generally not be allowed. Exceptions will be considered on a case by case basis when retention is required for the attenuation of flood peaks or other mitigating circumstances can be demonstrated.

8. The minimum culvert size for street crossings shall be 18 inches in diameter, except as allowed elsewhere in this manual. No storm drain conduit shall have a diameter less than that of the conduit upstream from it. Where the slope of the culvert is not sufficient to produce self-cleaning velocities, larger culvert sizes should be considered for maintenance requirements. Exceptions will be considered on a case by case basis when upstream ponding is required for the attenuation of flood peaks or other mitigating circumstances can be demonstrated.
9. Roadway cross culverts maintained by El Dorado County placed in drainage ways shall have flared end sections, beveled end sections, or headwalls on the inlet side. The outlet side shall have such end sections or slope protection that will return water to the normal flow without causing erosion.

- *Structural Design*

1. Drainage facilities shall conform to standards found in the *DISM* and in this manual. If applicable standards are not available, structural design shall be made and materials shall be specified by the civil engineer.
2. Drainage channels shall have side slopes of 2 to 1, or flatter unless mechanical stabilization is used. Bank stabilization and stream bed stabilization along constructed or natural channels is required if the channel velocities are sufficient to cause bank or bed erosion.
3. If closed conduit is used for storm drainage, access shall be provided at all angle points, grade breaks, and as required in Section 4 of this manual. Small diameter conduits with short runs may utilize drop inlet structures at angle points in place of manholes.
4. Drainage facilities located at areas subject to vehicular loading shall be able to withstand maximum legal vehicle loads and contain materials that will have a service life of 50 years pursuant to the testing methods for the selected material identified in the current State of California Department of Transportation *Standard Specifications*.

- *Easements for Drainage Purposes*

1. Drainage easements shall be shown on the parcel or final map and identified as such by the words "Drainage Easement." Combined

easements will be considered for approval pursuant to the requirements of shared use.

2. Drainage easements for closed conduits and appurtenances shall be no less than 10 feet in width and sufficient to provide 2 feet of clearance outside such conduits and appurtenances. Drainage easements for closed conduits shall not traverse under a building footprint and shall, insofar as possible, be placed away from the building footprint along, or adjacent to lot, boundary lines in a straight alignment without angle points.
3. Drainage easements for constructed channels and appurtenances shall be no less than 10 feet in width and sufficient to contain the top width of the channel plus an 8 foot continuous maintenance way on one side and 2 feet on the other side of channels less than 20 feet in top width. The maintenance way shall be 15 feet when the channel width is greater than 20 feet.

Drainage easements for minor conveyance swales shall be sufficient to contain the swale plus provide 2 feet of clearance on both sides of the top of the swale. Drainage easements to accommodate the drainage swale shall be shown on the parcel or final map and designated by the following statement:

A perpetual right of way over, upon, and across those strips of land between the rear and/or sidelines of lots and the lines shown hereon and designated "secondary flowage easement" for the purpose of preserving and forever leaving open an easement for the passage of surface drainage.

4. Drainage easements for natural waterways are subject to the following criteria:

Drainage ways originating within the subdivision and not receiving water from culverts or roadside ditches do not require easements. All other drainage ways and all watercourses require drainage easements reserved for drainage purposes.

Drainage easements for natural waterways shall be located and approximately shown within the lot or parcel.

Drainage easements shall be no less than 10 feet wide and sufficient to contain the channel plus additional space for a maintenance way.

Requirements for all watercourses within the jurisdiction of the State of California Department of Fish and Wildlife<sup>4</sup> shall be provided for by the drainage easement.

- *Drainage Easement Maintenance*
  1. Class I Subdivisions shall form a community services district or develop a county services area to provide drainage easement maintenance.
  2. For all other land divisions, drainage easements located outside the areas of El Dorado County rights of way shall have adequate provisions to ensure maintenance as a condition of the land division approval.

### **1.8.3 Submittal Requirements**

Submittal of a hydrologic and hydraulic analysis is required for all proposed drainage facilities. This requirement is applicable to discretionary applications for proposed developments including Class I Subdivisions, Rural Subdivisions, Minor Land Divisions (parcel maps), Commercial, Industrial and Multi-Family Developments to describe the drainage related facilities associated with any of the above activities. In cases where the applicant determines that drainage improvements are minor and would not require a detailed analysis, the applicant can request, in writing, an exemption from this submittal requirement be granted by the County Engineer. Applications will be reviewed on a case-by-case basis when mitigating circumstances can be demonstrated by the applicant.

Provisions in the *Grading Ordinance* also require submittal of a grading and drainage plan when surface drainage is discharged onto any adjoining property. An analysis of the effect of the discharge is required to be included with the submittal. Submittals may incorporate water quality planning documents if facilities will serve both water quality and volume purposes.

Drainage analysis submittals for minor land divisions shall include adequate supporting hydrologic and hydraulic information for the proposed improvements and supporting documentation including computations and any relevant information which will assist in the review process. Minor land divisions are defined in the *County of El Dorado Minor Land Divisions Ordinance No. 5026 – Subpart I* (2015).

---

<sup>4</sup> California Department of Fish and Game was succeeded by the California Department of Fish and Wildlife CC FGC Section 700(b).

Drainage analysis submittals to be provided with the submittal of design plans included in discretionary applications for major land divisions shall include a hydrologic and hydraulic analysis report. Major land divisions are defined in the *County of El Dorado Major Land Divisions Ordinance No. 5026 – Subpart II*. The following outlines requirements for the hydrologic and hydraulic analysis report.

- *Hydrologic and Hydraulic Analysis Report*

The hydrologic and hydraulic analysis report should include a complete analysis of proposed improvements and supporting documentation including computations and any relevant information which will assist in the review process. The report shall be prepared by a Civil Engineer who is registered in the State of California. The report shall bear the State of California Registered Professional registration seal with signature, license number and registration certificate expiration date of the Engineer responsible for the preparation of the report. The following information is considered as the minimum for inclusion in the drainage study submittal.

- *Introduction and Background*

The introduction and background should consist of a discussion of the proposed project including existing conditions. A discussion on the purpose and scope of the drainage study and a discussion on the purpose methodology for the analysis should also be included. The report should contain a description of the project site and a location map. A discussion of the level of detail for the study and general assumptions including those associated with parameter estimations considered for the analysis should be incorporated. Existing drainage problems or proposed alterations to existing drainage features or flows should be identified and thoroughly discussed. Discussion of constraints which influence selection of available alternatives should also be included.

- *Location Map/Description*

A discussion of the project area including a map identifying the location of the proposed project should be included in the study.

- *Catchment Description/Delineation*

The catchment tributary to project improvements and to downstream facilities being analyzed should be delineated on mapping sufficient to identify the parameters utilized in the analysis. Scale and detail should

be sufficient for the level of analysis. A base map created from information on a U.S.G.S. 7.5 minute quadrangle map will be considered as minimum required for the submittal.

- *Hydrologic Analysis*

The hydrologic analysis should include a presentation and discussions of the results obtained by the analysis and calculations performed pursuant to the guidelines set forth in Section 2 – Hydrology of this manual.

- *Hydraulic and Structural Analysis of Existing and Proposed Drainage Improvements*

The hydraulic and structural analysis should include a presentation and discussions of the results obtained by the analysis and calculations performed pursuant to applicable guidelines set forth in Sections 3 through 7 of this manual. The hydraulic and structural analysis should also include a discussion of the condition of existing drainage facilities including hydraulic capacities, flow characteristics and structural integrity. A discussion of the proposed drainage facilities should also be included with respect to the similar issues. Mapping should be included which is sufficient in detail to identify the drainage system and analytical parameters.

- *Risk Assessment/Impacts Discussion*

As a minimum, an evaluation of the significance of computed discharges with respect to flood protection, flood damage and redistribution of losses incurred by flooding should be included in the report. Vulnerability of exposure should be determined and proposed improvement levels of protection should be justified. Cost/benefit review of increased levels of protection and analysis/estimate of potential damage to property at risk should be investigated and discussed in the report. A discussion of any potential catastrophic losses including associated value should be adequately discussed when applicable.

Impacts to downstream facilities and other proposed mitigation measures included in the design should be discussed. Potential impacts resulting from back water effects, hydraulic scour and deposition, off-site discharges and other environmental issues should be thoroughly analyzed and discussed in the report.

- *Unusual or Special Conditions*

Any unusual or special conditions should be discussed in the report. These might include those related to existing facilities, physical or hydrological characteristics of the catchment and unusual or special requirements of the existing or proposed drainage system such as those related to operation or maintenance. Description of any special permits or special conditions required from regulatory agencies other than El Dorado County for the construction of proposed drainage improvements should be thoroughly discussed in the report.

- *Conclusions*

A conclusion section should be included in the report. Outcomes resulting from the proposed improvement analysis should be summarized and proposals, recommendations and requirements should be identified and adequately discussed.

- *Technical Appendix of Supporting Documentation for Calculations*

A technical appendix should be included in the report. The technical appendix should include documentation of the analysis including reference materials, documentation of parameter estimations used in the analysis, historical data used in the analysis, worksheets, computer input/output files, water surface profiles, cross section information and flood plain mapping. The appendix will be reviewed as the complete technical support data package.



## **Appendix 1.1 Additional Regulatory Requirements**

### **A1.1.1 Purpose and Scope**

Any given development project is subject to requirements or conditions based on broad authorities granted to various jurisdictions to provide protection from or mitigation of effects of the development. The purpose of this section is to identify and describe the basic authorities and their requirements in general terms.

### **A1.1.2 Basic Drainage Law Requirements**

Drainage law is primary case, or common law. Common law originates from the accumulation of many court decisions which become precedent for future similar occurrences.

Drainage law is complex; however, the courts have established some general principles which apply in general to development projects which are outlined as follows:

1. Under the natural watercourse rule, an upstream property owner is immune from any damage to downstream riparian property caused by surface water runoff within a natural watercourse.
2. An upstream property owner that alters or diverts a natural watercourse can be held liable for damage caused to the downstream property owner if the upstream property owner failed to take reasonable steps to avoid damage to the downstream property owner. The downstream property owner is also required to act reasonably to avoid damage. Similarly, a downstream property owner that alters or diverts a natural watercourse can be held liable for damage caused to an upstream property owner if the downstream property failed to act reasonably. The test for reasonableness requires consideration of all relevant circumstances, and anticipates both the upstream and downstream owners will act reasonably.
3. The California Supreme Court in *Locklin v. City of Lafayette* (1994) 7 Cal.4th 327, 337 articulated the reasonableness standard in California as follows:

“This test requires consideration of the purpose for which the improvements were undertaken, the amount of surface water runoff added to the streamflow by the defendant's improvements in relation to that from development of other

parts of the watershed, and the cost of mitigating measures available to both upper and downstream owners. Those costs must be balanced against the magnitude of the potential for downstream damage. If both plaintiff and defendant have acted reasonably, the natural watercourse rule imposes the burden of stream-caused damage on the downstream property.”

### ***A1.1.3 General Plans***

The General Plan is used by local government to define goals and policies regarding land use and development. The General Plan is empowered, and its scope prescribed, by state law. It is the basis of many derivative plans and ordinances which are intended to implement its goals and policies. The General Plan also grants discretionary powers to local planning commissions to impose specific conditions on projects to achieve broad goals and objectives.

### ***A1.1.4 Subdivision Map Act***

Specific drainage improvements or drainage fees and assessments may be imposed by the local jurisdiction largely based on powers granted in the Subdivision Map Act. The Subdivision Map Act is contained in Division 2 (commencing with Section 66410) of Title 7 of the Government Code. The sections of this Act specifically which provide authority for the imposition of conditions related to drainage requirements include Government Code Sections 66411; 66418; 66419; 66421; 66457; and 66483.

The Subdivisions Map Act gives local agencies the authority to: provide drainage facilities necessary for the general use of lot owners, the subdivision and the local neighborhood; to provide for proper grading and erosion control; to require dedication or irrevocable offers of dedication of real property within the subdivision for drainage easements; and to provide for the imposition and collection of fees needed to defer actual or estimated costs of constructing drainage facilities for the removal of surface and storm waters from local or neighborhood drainage areas.

The exact nature of these improvements may be specified in local ordinances which identify specific improvements such as storm sewers, subdrain systems, detention basins, pumps, and catch basins, or ordinances general in nature which simply require improvements for facilities to carry storm runoff.

Although local governments have broad authority to require drainage easements, that authority is limited by Sections 66411 and 66421 of the Subdivision Map Act which state that local ordinances be consistent with, and not in conflict with, the Subdivision Map Act.

#### ***A1.1.5 California Environmental Quality Act (CEQA)***

CEQA requires that local agencies disclose and consider the environmental implications of their actions and requires avoidance of environmental impacts where feasible. Mitigation requirements may be identified in a regional plan and fees or assessments imposed on specific developments within the plan area, or any specific development project may be required to assess and mitigate to avoid environmental impacts.

#### ***A1.1.6 Porter-Cologne Water Quality Control Act***

California Water Code Section 13000, et seq., also known as the Porter-Cologne Water Quality Control Act, gives the State of California, through the State Water Resources Control Board (SWRCB) and the various Regional Water Quality Control Boards (RWQCBs), the primary responsibility for control of state water quality. The primary enforcement mechanisms are Water Code Sections 13260, 13301, 13304, and 13266.

Section 13260 states that any person proposing to or discharging waste within any region that could affect state water quality, other than into a community sewer system, must file a report with the Board that contains such information as required by the Board. Proposed changes or changes in the character of any previously approved discharge require an additional report be filed. Criminal penalties can be attached to violations of the Act.

Section 13266 states that each citizen or county must notify the Board if a subdivision map is filed, or if a building permit is filed which may involve the discharge of waste other than from dwellings involving five families or less, or discharge other than to a community sewer system.

Finally, Section 13301 gives Boards the authority to issue Cease and Desist Orders for violations of the Act, while Section 13304 provides the State Attorney General with the power to petition the Superior Court for prohibitory or mandatory injunctions to stop violations of the Act.

Further, the Subdivision Map Act, Government Code Section 66474.6, provides that the governing body of a local agency shall determine whether discharge of waste from a proposed subdivision into an existing

community sewer system would cause a violation of existing Board requirements. If the proposed waste discharge would cause or add to such violations, the proposed subdivision can be denied.

#### ***A1.1.7 California Fish and Game Code***

The California Fish and Game Code also regulates drainage into a bed, channel, or bank of any river, stream, or lake. Specifically, Section 1602 of the Fish and Game Code makes it unlawful to substantially divert or obstruct the natural flow of, or substantially change or use any material from the bed, channel, or bank of any river, stream, or lake, or deposit or dispose of material containing pavement where it may pass into a river, stream, or lake, unless the person notifies the California Department of Fish and Wildlife (CDFW) and pays a fee. The person also has to enter into an agreement with the CDFW if the CDFW makes certain findings on the activity, unless an exception applies. The CDFW may impose constraints for protecting fish and wildlife as a condition of that agreement.

The CDFW has, in Section 720 of Title 14 of the California Code of Regulations, designated all rivers, streams, lakes, and streambeds in the state, including ones that have an intermittent flow of water, to fall within the protection of Section 1602 of the Fish and Game Code.

#### ***A1.1.8 Section 404 of the National Clean Water Act***

Section 404 of the Clean Water Act “prohibits the placement or discharge of fill or dredged material into waters of the United States” without a permit from the Corps of Engineers.” (1985). “Waters of the United States” includes streams which “...are periodically or permanently inundated by surface or ground water and support vegetation adapted for life in saturated soil.”

This includes much of the natural drainage in El Dorado County.

The USACE coordinates the concerns of various reviewing agencies and the public. Permits are circulated among these parties, and any conditions to the permit are based on their legitimate concerns. Procedures and requirements are further explained in the “Regulatory Program, Applicant Information,” USACE’s, *Engineer Pamphlet No. EP 1145-2-1*, 1985.

### ***A1.1.9 National Flood Insurance Program***

The National Flood Insurance Program was developed in 1968 to: provide federally subsidized insurance policies to the owners of flood plain properties; and provide incentives to local government to plan and regulate land use and building design in flood hazard areas. This program is set forth in the National Flood Insurance Act (42 U.S.C. Sections 4041-4131).

FEMA has overall, and very broad, responsibility for administering the National Flood Insurance Program, but local communities participating in this program review specific development proposals to assure that structures which may be in a 100-year floodplain are protected from flood damages and that any changes in the floodplain do not cause unacceptable increases in the elevation of the 100-year water surface. Property developers may be held liable for designing and/or constructing drainage projects which aggravate existing insurance risks.

### ***A1.1.10 Section 402 of the Clean Water Act - National Pollutant Discharge Elimination System (NPDES) Program***

Clean Water Act Section 402 is officially administered by the U.S. Environment Protection Agency (USEPA) and addresses water pollution by regulating point sources that discharge pollutants to waters of the United States. In California, USEPA has delegated its authority to the SWRCB, which, in turn, delegates implementation responsibility to the nine RWQCBs. The NPDES Program is the permitting mechanism that requires the implementation of controls designed to prevent harmful pollutants from being washed by stormwater runoff into local water bodies. The NPDES program provides both general (those that cover a number of similar or related activities) and individual (activity- or project-specific) permits. NPDES permits typically applicable to the County of El Dorado include Municipal Separate Storm Sewer Systems (MS4) permits, the Construction General Permit (CGP), the Industrial General Permit (IGP), and Waste Discharge Requirements (WDR) Permits.

- ***NPDES MS4 Permitting Program***

The SWRCB regulates stormwater discharges from MS4s through its MS4 Program. USEPA defines an MS4 as a conveyance or system of conveyances (including roads with drainage systems, municipal streets, catch basins, curbs, gutters, ditches, man-made channels, or storm drains) owned or operated by a State. Permits are issued under two phases depending on the size of the urbanized area/municipality. Phase I MS4 Permits are issued for medium and large municipalities, and are

often issued to a group of co-permittees within a metropolitan area. The SWRCB began issuing Phase II Permits for small municipalities (population less than 100,000) in 2003. Both Phase I and Phase II MS4 Permits include the following six minimum control measures: 1) Public Education and Outreach, 2). Public Participation and Involvement, 3). Illicit Discharge Detection and Elimination (IDDE), 4). Construction Site Runoff Control, 5). Post-construction Runoff Control, and 6). Pollution Prevention and Good Housekeeping. The County of El Dorado is covered under two RWQCBs. The West Slope Phase II MS4 NPDES Permit is administered by the Central Valley RWQCB (Region 5). The Lake Tahoe Phase I MS4 NPDES Permit is administered by the Lahontan RWQCB (Region 6). In May 2015, the County adopted a County-Wide Storm Water Quality Ordinance (Ordinance No. 5022) to ensure compliance with MS4 Permit requirements to the Maximum Extent Practicable (MEP) standard.

- *NPDES CGP Permitting Program*

The SWRCB regulates discharges from projects that disturb one (1) acre or more of soil or from projects that disturb less than one acre but are part of a larger common plan of development. Discharges are required to obtain coverage under the CGP prior to the commencement of ground disturbing activities. The CGP requires the development of a Storm Water Pollution Prevention Plan (SWPPP) and permittees are further required to monitor construction activities and report compliance to ensure that BMPs are correctly implemented and are effective in controlling the discharge of construction-related pollutants.

## **Appendix 1.2 Definitions**

The definitions set forth in this section are to provide for a consistent understanding of the terms related to drainage engineering in El Dorado County. Certain specialized definitions are defined in each individual part where they apply.

Acre-Foot – The amount of water that will cover one acre to a depth of one foot. (Equals 43,560 cubic feet).

Act of God – Rainfall, inundation, flooding, and general storm runoff damage arising from natural causes without the intervention of mankind, and which human prudence could not foresee or prevent.

Appurtenances to Storm Drains – Structures, devices, and appliances, other than pipe or conduit, which are an integral part of a drainage system, such as manholes, storm water inlets, detention storage facilities, etc.

Apron – A floor or lining of concrete, timber, or other suitable material at the toe of a dam, discharge side of a spillway, a chute, or other discharge structure, to protect the waterway from erosion from falling water or turbulent flow.

Backfill – (1) The operation of filling an excavation after it has once been made, usually after some structure has been placed therein. (2) The material placed in an excavation in the process of backfilling.

Backwater – The increase in water surface elevation induced upstream from such things as a bridge, culvert, dike, dam, another stream at a higher stage, or other similar structures or conditions that obstruct or constrict a channel relative to the elevation occurring under natural channel and floodplain conditions.

Backwater Effect – Increase in upstream depth above normal depth due to channel obstruction, confinement of flow or abrupt change in channel section, slope, roughness or alignment.

Backwater Curve – The term applied to the longitudinal profile of the water surface in an open channel when flow is steady, but non-uniform.

Baffles – Deflector vanes, guides, grids, gratings, or similar devices constructed or placed in flowing water to, (1) check or effect a more uniform distribution of velocities, (2) absorb energy, (3) divert, guide, or agitate the liquids, and (4) check eddy currents.

Bank – The lateral boundary of a stream or channel confining water flow.

Base Flood – The flood having a one percent chance of being exceeded in any given year. The “base flood” is commonly used as the “standard flood” in federal flood insurance studies.

Base Floodplain – The area subject to flooding by the base flood.

Bedding – The foundation under a drainage structure.

Bed Load – Sediment that moves by rolling, sliding or skipping along the bed and is essentially in contact with the stream bed.

Berm – A horizontal stripe or shelf built into an embankment or cut, to break the continuity of an otherwise long slope, usually for the purpose of reducing erosion, improving stability, or to increase the thickness or width of cross section of an embankment.

Bridge – A structure for carrying traffic over a watercourse, depression, or other obstacle.

CalTrans – California Department of Transportation.

Capacity – The effective carrying ability of a drainage structure or facility. May also refer to storage capacity.

Carry Over – The quantity of water which continues past an inlet.

Catch Basin – A basin combined with a storm drain inlet to trap solids.

Catchment Area – (1) The contributing area to a single drainage basin, expressed in acres, square miles, or other unit of area. Also called Drainage Area or Watershed. (2) The area served by a drainage system receiving storm and surface water; or by a water-course.

Channel – (1) A natural or artificial watercourse of perceptible extent which periodically or continuously contains moving water, or which forms a connecting link between two bodies of water. It has a definite bed and banks which serve to confine the water. (2) The deep portion of a river or waterway which is used by watercraft. Also see Watercourse.

Channel Storage – The volume of water stored in a channel. Generally considered in the attenuation of the peak of a flood hydrograph moving downstream.

Check – A barrier placed in a ditch, canal or channel to decrease the velocity of the flow of water so as to minimize erosion of the bottom and



banks or to raise the level of the water. Also used for diverting water from one channel to another, as in irrigation usage.

Chute – An inclined conduit or structure used for conveying water at a high velocity to lower levels. For vertical structures, see Drop.

Concentrated Flow – Flow which is altered from its natural surface runoff and has accumulated into a single narrow ditch, channel or pipe.

Conduit – Any pipe, arch or box through which water is conveyed.

Confluence – A junction of streams or channels.

Control – A section or reach of an open conduit or channel which maintains a stable relationship between stage or discharge.

Conveyance – A measure of the water carrying capacity of a stream or channel.

Cost/Benefit Ratio – A comparison of the cost of a project with the good accruing from it.

County Engineer – Department of Transportation, Deputy Director of Development, Right of Way and Environmental (DRE).

Course – A natural or artificial channel for passage of water.

Cross-Street Flow – Flow across the traffic lanes of a street from external sources, as distinguished from sheet flow of water falling on the pavement surface.

Culvert – A closed conduit for the passage of surface drainage water under or over a roadway, railroad, canal, or other impediment.

Culvert, Box – Generally, a rectangular or square concrete structure for carrying large amounts of water under a roadway. This term is sometimes applied to long underground conduits.

Dam – A barrier constructed across a watercourse for the purpose of (1) creating a reservoir, (2) diverting water therefrom into a conduit or channel.

Datum – A plane, level, or line from which heights and depths are calculated or measured.

Debris Basin – A basin formed behind a low dam, or an excavation in a stream channel, to trap debris or bed load carried by a stream. The value of a basin depends on cleaning-out of debris periodically to restore its capacity.

Detention – Temporary ponding of stormwater to attenuate or reduce peak runoff rates.

Detention, Upstream – Normally used for the detention of water close to the point of rainfall occurrence, usually applied to rooftop ponding, parking lot ponding, and small storage basins.

Development – Any man-made change to improved or unimproved real estate, including but not limited to buildings or other structures, mining, dredging, filling, grading, paving, excavation or drilling operations.

Discharge – A volume of water flowing past a given point per unit time. In its simplest concept, discharge means outflow; therefore, the use of this term is not restricted as to course or location, and it can be applied to describe the flow of water from a pipe or from a drainage basin. If the discharge occurs in some course or channel, it is correct to speak of the discharge of a canal or stream into a lake, stream, or ocean.

DISM – *The Design and Improvements Standards Manual* (or subsequent document) of the County of El Dorado.

Diversion – The change in character, location, direction, or quantity of flow of a natural drainage course.

DOT – El Dorado County Department of Transportation.

Drainage – (1) A general term applied to the removal of surface or sub-surface water from a given area either by gravity or by pumping. The term is commonly applied herein to surface water. (2) The area from which water occurring at a given point or location on a stream originates. In such case, the term is synonymous with Drainage Area and Watershed. (3) The term is also used in a general sense to apply to the flow of all liquids under the force of gravity.

Drainage Area – See Catchment Area.

Drainage Way – Those natural depressions in the earth's surface, such as swales, ravines, draws and hollows, in which surface waters tend to collect, but which do not constitute a watercourse in the defined sense.

Drains – A pipe, ditch, or channel for collecting and conveying water. Sometimes used in “Storm Drains” when describing an urban storm drainage system to carry the initial runoff.

Drawdown – The vertical distance the free water elevation is lowered or the reduction of the pressure head due to the removal of free water.

Drop – A vertical structure in a conduit or canal installed for the purpose of dropping water to a lower level.

Drop Inlet Culvert – A culvert installed with a drop inlet on one end and daylighted at the other end.

Encroachment – The advance or infringement of uses, plant growth, fill, excavation, buildings, permanent structures or development into a floodplain which may impede or alter the flow capacity of a floodplain.

Energy Dissipator – A structure for the purpose of slowing the flow of water and reducing the erosive forces present in any rapidly flowing body of water.

Erosion – Wearing away of the lands by running water and waves, abrasion, and transportation.

FEMA – Federal Emergency Management Agency.

Flood – A general and temporary condition of partial or complete inundation of normally dry land areas from the overflow of inland or tidal waters; the unusual and rapid accumulation or runoff of surface waters from any source.

Flood Control – The elimination or reduction of flood losses by the construction of flood storage reservoirs, channel improvements, dikes, and levees, by-pass channels, or other engineering works.

Flood Plain – Any land area susceptible to being inundated by water from any source. Land formed by deposition of sediment by water; alluvial land.

Flood Plain Management – Control of use of land subject to flooding.

Flood Proofing – A combination of structural changes and adjustments to properties subject to flooding primarily for the reduction of flood damages.

Flood Storage – Storage of water during floods to reduce downstream peak flows.

Flood Plain Fringe – That portion of the flood plain that lies outside the regulatory area. Its hazard should be recognized although it is not great enough to make public regulations desirable.

Flood Waters – Waters which escape from a watercourse in great volume and flow over adjoining lands in no regular channel, though the fact that such errant waters make for themselves a temporary channel or follow some natural channel, gully or depression, does not affect their character as flood waters or give to the course which they follow the character of a natural watercourse.

Floodway – Floodway is that portion of the regulatory area required for the reasonable passage or conveyance of the design flood. This is the area of significant depths and velocities, and due consideration should be given to effects of fill, loss of cross sectional flow area, and resulting increased water surface elevations.

Flood Storage Area – Flood storage area is that portion of the regulatory area that may serve as a temporary storage area for flood waters from the 100-year flood and that lies landward of the floodway.

Flow – A term used to define the movement of water, silt, sand, etc.; discharge; total quantity carried by a stream.

Flow Line – (1) The position of the water surface in a flowing stream or conduit for a normal or specified rate of discharge. (2) The hydraulic grade line in an open channel.

Freeboard – The vertical distance between the normal maximum level of the surface of the liquid in a conduit, reservoir, tank, basin, canal, etc., and the top of the confining structure, which is provided so that waves and other movements of the liquid will not overtop such confining structures.

Frequency Curve – A curve that expresses the relation between the frequency of occurrence and the magnitude of the variables. The theoretical frequency curve is a derivative of the probability curve.

Gabion – A wire basket containing earth or stones, deposited with others to provide protection against erosion.

Grade – (1) The inclination or slope of a channel, canal, conduit, etc., or natural ground surface, usually expressed in terms of the percentage of number of units of vertical rise (or fall) per unit of horizontal distance. (2) The elevation of the invert of the bottom of a conduit, canal, culvert, sewer,

etc. (3) The finished surface of a canal bed, road bed, top of an embankment, or bottom of an excavation.

Gutter – See Street Nomenclature

Gutter Flow – Flow in a gutter.

Habitable Structure – Any building or structure which would suffer significant damage to inundation of flood waters.

Headwater – (1) The upper reaches of a stream near its source. (2) The region where ground waters emerge to form a surface stream. (3) The water upstream from a structure.

Hydraulics – A branch of science that deals with practical applications of the mechanics of water movements.

Hydraulic Gradient – A hydraulic profile of the piezometric level of the water, representing the sum of the depth of flow and the pressure. In open channel flow, it is the water surface.

Hydraulic Jump – The hydraulic jump is an abrupt rise in the water surface which occurs in an open channel when water flowing at supercritical velocity is retarded by water flowing at subcritical velocity. The transition through the jump results in a marked loss of energy, evidenced by turbulence of the flow within the area of the jump. The hydraulic jump is often used as a means of energy dissipation.

Hydrograph – A graph showing stage, flow, velocity, or other property of water with respect to time.

Hydrology – The science that deals with the processes governing the occurrence and movement of water upon and beneath the land areas of the earth.

Impervious – A term applied to a material through which water cannot pass, or through which water passes with great difficulty.

Infiltration – (1) The entering of water through the interstices or pores of a soil to other porous medium. (2) The quantity of ground-water which leaks into a sanitary or combined sewer or drain through defective joints. (3) The entrance of water from the ground into a sewer or drain through breaks, defective joints, or porous walls. (4) The absorption of liquid water by the soil, either as it falls as precipitation, or from a stream flowing over the surface. See Surface Infiltration.

Inlet – (1) An opening into a storm sewer system for the entrance of surface storm runoff, more completely described as a storm sewer inlet. (2) A structure at the diversion end of a conduit. (3) The upstream connection between the surface of the ground and a drain or sewer, for the admission of surface or storm water.

Inlet Gratings –

- a. Longitudinal Bar Grate – A grate in which the bars are oriented parallel to the direction of the flow.
- b. Transverse Bar Grate – A grate in which the bars are located at some angle, usually perpendicular to the direction of flow.

Inlet Types –

- a. Combination Inlet – An inlet composed of a curb opening and a grated gutter opening inlet acting as a unit. Usually the gutter opening is placed directly in front of the curb opening. This arrangement is called a contiguous combination inlet, or more simply a combination inlet. When the curb and gutter openings are placed in an overlapping, or end to end position, the arrangement is called an overlapping, offset, or special combination inlet.
- b. Curb opening Inlet – A vertical opening in a curb through which the gutter flow passes. The gutter may be undepressed or depressed in the area of the curb opening.
- c. Grated Inlet – An opening in the gutter covered by one or more grates through which the water falls. As with all inlets, grated inlets may be either depressed or undepressed and may be located either on a continuous grade or in a sump.
- d. Multiple Inlet – Two or more closely spaced inlets acting as a unit. The two inlets may be of any of the types mentioned above.

Intensity – As applied to rainfall, is a rate usually expressed in inches per hour.

Interception – As applied to hydrology, refers to the process by which precipitation is caught and held by foliage, twigs, and branches of trees, shrubs and buildings, never reaching the surface of the ground, and is lost by evaporation.

Invert – The bottom of a drainage facility along which the lowest flows would pass.

*Isohyetal Line* – A line drawn on a map or chart joining points which receive the same amount of precipitation.

*Isohyetal Map* – A map containing isohyetal lines and showing rainfall intensities.

*Left Bank* – The left-hand bank of a stream or dam when the observer is facing downstream.

*Lining* – Material such as concrete, rock, cobbles, grass, geotextiles, etc., placed on the sides and bottom of a ditch, channel, and reservoir to prevent or reduce seepage of water through the sides and bottom and/or to prevent erosion.

*Lip* – A small wall on the downstream end of an apron, to break the flow from the apron.

*Manhole* – A structure through which a person may gain access to an underground or enclosed conduit or facility.

*Nappe* – The sheet or curtain of water overflowing a weir or dam. When freely overflowing any given structure, it has a well-defined upper and lower surface.

*NRCS* – Natural Resources Conservation Service (formerly the Soil Conservation Service).

*NOAA* – National Oceanic and Atmospheric Administration.

*NWS* – National Weather Service.

*Orifice* – (1) An opening with closed perimeter and of regular form in a plate, wall, or partition, through which water may flow. (2) The end of a small tube, such as a Pitot tube, piezometer, etc.

*Peak Rate of Runoff* – The maximum rate of runoff during a given runoff event.

*Permeability* – The quality of a soil horizon which permits movement of water through it when saturated and actuated by hydrostatic pressure.

*Pervious* – Applied to a material through which water passes relatively freely.

Point of Concentration – That point at which water flowing from a given drainage area concentrates.

Pollution – A state of physical impurity or uncleanliness, usually brought about by the addition of sanitary sewage, harmful industrial waste, or other harmful materials to water which make it unfit for use.

Precipitation – Any moisture that falls from the atmosphere, including snow, sleet, rain, and hail.

Reach – Any length of river or channel. Usually used to refer to sections which are uniform with respect to discharge, depth, area or slope, or sections between gaging stations.

Regime – The system of order characteristic of a stream; its behavior with respect to velocity and volume, form of and changes in channel, capacity to transport sediment, amount of material supplied for transportation, etc.

Retention – Containment of runoff by ponding to be discharged by infiltration and evaporation or by release after the storm has ended.

Riprap – Broken stone or boulders placed compactly or irregularly on dams, levees, ditches, dikes, etc., for protection of earth surfaces against the erosive action of water.

Right Bank – The right-hand bank of a stream or dam when the observer is facing downstream.

Riparian – Pertaining to the banks and other adjacent, terrestrial environs of freshwater bodies, watercourses, and surface emergent aquifers, whose imported waters provide soil moisture significantly in excess of that available through local precipitation.

Risk – The potential adverse consequences measured in terms of inconvenience, damage, safety or professional liability or political retribution. (WEF/ASCE, 1992).

Risk Analysis – The quantification of exposure, vulnerability and probability. (WEF/ASCE, 1992).

Routing, Hydraulic – (1) The derivation of an outflow hydrograph of a channel or stream from known values of upstream inflow. (2) The process of determining progressively the timing and shape of a flood wave at successive points along a stream or channel.



Runoff – That part of the precipitation which reaches a stream, drain, sewer, etc., directly or indirectly.

- a. Direct Runoff – The total amount of surface runoff and subsurface storm runoff which reaches stream channels.
- b. Overland Runoff – Water flowing over the land surface before it reaches a definite stream channel or body of water.

Sanitary Sewer – A closed conduit carrying sewage and other waste liquids, but not including intentionally added surface and storm water.

Scour – The erosive action of running water in streams or channels in excavating and carrying away material from the bed and banks.

SCS – Soil Conservation Service (now the Natural Resources Conservation Service).

Sediment – Material of soil and rock origin transported, carried, or deposited by water.

Sheet flow – Any flow spread out and not confined, i.e., flow across a flat open field.

Silt Basin – A basin or reservoir installed in a storm drainage system to retard velocity, causing sedimentation and providing storage for deposited solids.

Slope – See Grade.

Spillway – A waterway in or about a dam or other hydraulic structure, for the escape of excess water. Also referred to as By-Channel, By-Wash, and Diversion Cut.

Stage – The elevation of a water surface above its minimum; also above or below an established “low water” plane; hence above or below any datum of reference; gauge height.

Storm – A disturbance of the ordinary, average conditions of the atmosphere which, unless specifically qualified, may include all meteorological disturbances such as wind, rain, snow, hail, or thunder.

Storm Sewer – A closed conduit for conducting storm water that has been collected by inlets or collected by other means. The various parts of a drainage system are defined as follows:

- a. Lateral (Collection) Storm Sewer – A sewer that has inlets connected to it but has no other storm sewer connected.
- b. Branch (Submain) Storm Sewer – A sewer which receives runoff from a relatively small area and discharges into a trunk or main sewer, and may or may not have inlet connections.
- c. Trunk (Main) Storm Sewer – A sewer which receives the discharge from several branches (submains) and generally serves a relatively large area, and may or may not have inlet connections.
- d. Outfall Storm Sewer – A sewer which receives the runoff from a collecting system, such system being lateral (collection) storm drains, branch (submain) storm sewers, and trunk (main) storm sewers, as are required, and carries such runoff to a point of final discharge.
- e. Relief Storm Sewer – A storm sewer that is provided to relieve a storm drainage system which does not have the capacity to carry off the Design Storm.

Storm Drainage System – All facilities used for conducting the storm water through and from a drainage area to the point of final outlet, consisting of any or all of the following: conduits and appurtenant features, canals, channels, ditches, streams, gulches, gullies, flumes, culverts, streets, and pumping stations.

Storm Runoff – The water from precipitation running off the surface of a drainage area during and immediately following a period of rain.

Stream – A body of water flowing in a natural surface channel.

- a. Continuous – A stream which habitually flows or contains water throughout its entire course, or between any two points on its course.
- b. Effluent – A stream or stretch of stream which receives water from ground water in the zone of saturation. The water surface of such a stream stands at a lower level than the water table or piezometric surface of the ground water body from which it receives water.
- c. Ephemeral – (1) One that flows only in direct response to precipitation. Such a stream receives no water from springs and no long-continued supply from melting snow or other surface source. Its channel is at all times above the water table. (2) The term may be arbitrarily restricted to streams or stretches of streams that do not flow continuously during periods of as much as one month.

- d. Influent – A stream or stretch of stream which contributes water to the zone of saturation. The water surface of such a stream stands at a higher level than the water table or piezometric surface of the ground water body to which it contributes water.
- e. Intermittent – A stream which flows during protracted periods, but not continually, when it receives water from springs or surface runoff.
- f. Perennial – A stream which flows continuously at all seasons of a year and during dry as well as wet years. Such streams are usually fed by ground water, and their water surface generally stands at a lower level than that of the water table in the locality.

Stream Flow – A term used to designate the water which is flowing in a stream channel, canal, ditch, etc.

Stream Response – Changes in the dynamic equilibrium of a stream by any one, or combination of various causes.

Street Flow – The total flow of storm runoff in a street, usually being the sum of the gutter flows on each side of the street. Also the total flow where there are no curbs and gutters.

Street Nomenclature –

- a. Cross Fall – In a lateral pavement cross-section, it is the difference in the elevation between the gutter flow lines.
- b. Cross Pan – A concave paved surface crossing a street, usually at pavement intersections, for the purpose of carrying surface water across the street to continue the surface flow.
- c. Crown – In the pavement, it is the highest point in the paving cross-section.
- d. Crown Slope – The slope of the pavement perpendicular to the crown.
- e. Curb – The lateral side of the pavement terminated by either a vertical or a sloped section.
- f. Curb and Gutter Section – A curb section constructed integrally with the gutter.
- g. Grade – The longitudinal slope measured along the crown.

h. Gutter – A paved section designed to carry surface flow. Often the gutter is terminated with a curb when located at the edge of a street section.

Subdrain – An underground conduit designed to permit infiltration for the purpose of collecting ground water.

Subgrade – (1) The bottom of a trench, or other excavation, that is somewhat below the predetermined elevation of the bottom of the final excavation or structure which is to be placed therein, the intervening space being backfilled with some special material such as sand, gravel, broken stone, or tamped earth, or impervious lining, or occupied by the structure for which the excavation was made. The term is also applied to the elevation of such bottom. (2) The natural soil area beneath a street or road.

Subsoil – That portion of a normal soil profile underlying the surface or A-horizon. Its depth and physical properties control to a considerable degree the movement of soil moisture.

Sump – Low point in natural or improved surface topography where surface flows will pond if a drain is not provided.

Sump Condition – Water restricted to an inlet area because the inlet is located at a low point.

Surface Detention – The storm runoff detained on the surface of the ground at or near where the rainfall occurred, and which will run off later.

Surface Flow or Sheet Flow – The surface flow from rainfall on pavements, ground surfaces, and other exposed surfaces until such flow reaches a gutter, ditch, water course, inlet, or other point of concentration.

Surface Infiltration – That rainfall which percolates into the ground surface and which therefore does not contribute directly to the storm runoff flow.

Surface Runoff – The movement of water on earth's surface, whether flow is over the surface of the ground or in channels.

Suspended Load – Sediment that is supported by the upward components of turbulent currents in a stream and that stays in suspension for an appreciable amount of time.

Swale – A shallow, gentle depression in the earth's surface. This tends to collect the waters to some extent as a drainage course, although waters in a swale are not considered stream waters.

Trash Rack – A grid, screen, or other barrier constructed to catch debris and exclude it from a downstream conduit.

Trench – An excavation made for installing pipes, masonry walls, and other purposes. A trench is distinguished from a ditch in that the opening is temporary and is eventually backfilled.

Tributary Basin – An area tributary to a specific point under study.

Water, Various Forms –

- a. Diffused Surface – (1) Flood water which has escaped from a stream channel. (2) Water on its way to a stream which has not reached a defined channel, and which is derived from rainfall, melting snow, seepage, or springs.
- b. Drainage – (1) Water which has been collected by a drainage system and discharged into a watercourse. (2) Water flowing in a drain derived from ground, surface, or storm water.
- c. Foreign – Water occurring in a stream or other body of water which originated in another drainage basin.
- d. Ground – Water in the ground beneath the surface. In a strict sense, the term applies only to water below the water table.
- e. Storm – The water from precipitation running off the surface of a drainage area during and immediately following a period of rain.
- f. Stream – Former surface waters which have gathered together into a well-defined watercourse.
- g. Surface – Waters are those falling upon, arising from, and naturally spreading over lands and produced by rainfall, melting snow, or springs. They continue to be surface waters until, in obedience to the laws of gravity, they percolate through the ground or flow vagrantly over the surface of the land into well-defined watercourses or streams.

Watercourse – A running stream of water, a natural stream, or storm water channel, including rivers, creeks, runs, and rivulets. Streams flow in a particular direction though it need not flow continually. They may sometimes be dry, and they usually flow in a definite channel having a bed, sides, or banks. It does not include the water flowing in the hollows or ravines in land, which is the surface water from rain or melting snow and is discharged through them from a higher to a lower level, but which at

other times are destitute of water. Also known as Drainage Way and Waterway.

- a. Artificial – A surface watercourse constructed by human agencies, usually referred to as channel, canal, or ditch.
- b. Natural – A surface watercourse created by natural agencies and conditions.

Watershed – See Catchment Area.

Wetland – A zone periodically or continuously submerged or having high soil moisture, which has an aquatic or riparian component or both, and is maintained by imported water supplies in excess of those available through local precipitation.

### **Appendix 1.3 References**

- Chow, V.T, Maidment, D.R., and Mays, L.W. (1988). *Applied Hydrology*. McGraw-Hill. New York, NY.
- Denver Regional Council of Governments (1978). *Urban Storm Drainage Criteria Manual, Volume 1*. Denver, CO.
- High Sierra Resource Conservation and Development Council (1991). *Erosion & Sediment Control Guidelines for Developing Areas of the Sierra Foothills and Mountains*. County of El Dorado, CA.
- Maidment, D.R. (1992). *Handbook of Hydrology*. McGraw-Hill. New York, NY.
- Orange County Environmental Management Agency (1986). *Hydrology Manual*. County of Orange, CA.
- Pilgrim, D.H. and Cordery, T. I. (1975). "Rainfall Temporal Patterns for Design Floods." *ASCE Journal of the Hydraulics Division*, 101(HYI), Jan., 1975, pp. 81-85.
- Placer County Flood Control and Water Conservation District (1990). *Stormwater Management Manual*. Auburn, CA.
- Psomas and Associates (1991). *El Dorado County Drainage Manual (Draft)*. Sacramento, CA.
- Soil Conservation Service (1986). "Urban Hydrology for Small Watersheds." *Technical Report 55*. USDA, Springfield, VA.
- Stahre, P. and Urbonas, B. (1990). *Stormwater Detention*. Prentice Hall. Englewood Cliffs, NJ.
- Storm Water Quality Task Force (1993). *California Storm Water Best Management Practice Handbooks*. State of California.
- Tahoe Regional Planning Agency (1986). *Handbook of Best Management Practices*. Zephyr Cove, NV.
- Water Environment Federation/American Society of Civil Engineers (1992). *Design and Construction of Urban Stormwater Management Systems*. New York, NY.
- See Appendix 1.3.1 for updated references*

### **Appendix 1.3.1 Updated References**

Listed below are the updated versions of select references for this section or references that were absent from the original *Drainage Manual*. If an updated version was not available, the original version should be referenced.

California Department of Transportation (2018). *Standard Specifications*. Sacramento, CA.

California State Water Resources Control Board. Municipal Stormwater Program Website. State of California.  
[https://www.waterboards.ca.gov/water\\_issues/programs/stormwater/municipal.html](https://www.waterboards.ca.gov/water_issues/programs/stormwater/municipal.html)

California Stormwater Quality Association (2003). *Stormwater Best Management Practice Handbooks*. State of California.

County of El Dorado (1990). *Design and Improvement Standards Manual*. Placerville, CA.

County of El Dorado (2006). Combined El Dorado County Resource Conservation District and El Dorado County Department of Transportation Erosion Control Requirements and Specifications. Placerville, CA.

County of El Dorado (2010). *Grading, Erosion, and Sediment Control*. Ordinance No. 4949. Placerville, CA.

County of El Dorado (2010). *Uniform Building Code*. Ordinance No. 4948. Placerville, CA.

County of El Dorado (2015). *Stormwater Quality*. Ordinance No. 5022. Placerville, CA.

County of El Dorado (2015). *Major Land Divisions*. Ordinance No. 5026 – Subpart I. Placerville, CA.

County of El Dorado (2015). *Minor Land Divisions*. Ordinance No. 5026 – Subpart II. Placerville, CA.

County of El Dorado (2018). *General Plan Land Use Element*. Placerville, CA.

County of El Dorado (2018). *Onsite Wastewater Treatment Systems*. Ordinance No. 5049. Placerville, CA.



- Federal Highway Administration (2008). "Introduction to Highway Hydraulics," *Hydraulic Design Series No. 4 (HDS-4)*. Washington, DC.
- Orange County Environmental Management Agency (1996). *Hydrology Manual 1996 Addendum*. County of Orange, CA.
- Stahre, P. and Urbonas, B. (1993). *Stormwater: Best Management Practices and Detention for Water Quality, Drainage, and Cso Management*. Prentice-Hall, Incorporated. Englewood Cliffs, NJ.
- Tahoe Regional Planning Agency (2014). *Best Management Practices Handbook*. Lake Tahoe, CA.
- U.S. Army Corps of Engineers (1985). "Regulatory Program, Applicant Information." *Engineer Pamphlet No. EP 1145-2-1*. Washington, DC.
- Urban Drainage and Flood Control District (2016). *Urban Storm Drainage Criteria Manual, Volume 1: Management, Hydrology, and Hydraulics*. Denver, CO.

**Section  
2**

**Hydrology**

Design and construction of stormwater management facilities in El Dorado County are regulated by standards set by the Board of Supervisors. These standards govern the long-term level of protection to be provided by the facilities. In most cases, the level of protection is defined explicitly in terms of a design storm that must be controlled, contained, or otherwise managed in the interest of public safety. This section defines these design storms and describes accepted procedures for estimating the magnitude in El Dorado County.

**Contents of this section**

- 2.1 Background..... 2-2
- 2.2 Overview ..... 2-3
  - 2.2.1 Analysis Steps ..... 2-3
  - 2.2.2 Appropriate Stormwater-runoff Computation Method ..... 2-4
  - 2.2.3 Exceptions ..... 2-5
- 2.3 Design Precipitation ..... 2-5
  - 2.3.1 Design-storm Duration..... 2-6
  - 2.3.2 Design-storm Depth..... 2-7
  - 2.3.3 Design-storm Temporal Distribution ..... 2-9
- 2.4 Hydrograph Method ..... 2-11
  - 2.4.1 Runoff Volume..... 2-12
  - 2.4.2 Runoff Hydrograph ..... 2-14
- 2.5 Peak-discharge Method ..... 2-18
- 2.6 Baseflow ..... 2-23
- 2.7 Complex Catchment Analysis ..... 2-24
  - 2.7.1 Subcatchment Delineation..... 2-24
  - 2.7.2 Streamflow Routing ..... 2-25
  - 2.7.3 Water-control Measures ..... 2-27
- 2.8 Reasonableness ..... 2-27
- 2.9 Computer Programs..... 2-28
  - 2.9.1 NRCS Program TR-55..... 2-28
  - 2.9.2 USACE Program HEC-1 and HEC-HMS ..... 2-28
  
- Appendix 2.1 References..... 2-29
  - Appendix 2.1.1 Updated References..... 2-31
  - Appendix 2.2 El Dorado County Design Rainfall Data..... 2-32
  - Appendix 2.3 NRCS Curve Number Tables..... 2-48
  - Appendix 2.4 USGS Regional Frequency Estimates ..... 2-55
  - Appendix 2.5 HEC-1 Input Example ..... 2-56

## **2.1 Background**

Design criteria for stormwater management facilities in El Dorado County are “standard-based” (WEF/ASCE, 1992). That is, design is based on an adopted set of regulatory standards. In El Dorado County, these standards are based on risk of facilities failing (hydraulically) to provide protection from flooding due to the largest discharge in any year. That risk is specified in terms of return period: the long-term average time between failures. Return period is the reciprocal of annual probability of exceedance. Thus the 10-yr discharge has annual probability of exceedance equal 0.10, and a facility designed for the 10-yr discharge has annual probability of 0.10 of failing to provide protection from the annual maximum flood. Likewise, a facility designed to carry the 100-yr discharge has annual probability of failure equal 0.01.

If sufficient streamflow data were available throughout El Dorado County, design discharges for specified return periods (quantiles) could be estimated for current conditions with statistical-analysis methods. In the U.S., standards for such analysis were proposed by the Interagency Advisory Committee on Water Data<sup>5</sup> in Bulletin #17B (1982). The procedure in Bulletin #17B uses recorded annual maximum discharge to calibrate a statistical model with which quantiles can be predicted. Unfortunately, this procedure is of limited use for design-discharge estimation in El Dorado County because:

- Few streams in developing areas of El Dorado County are gauged.
- Land-use changes alter the response of a catchment to rainfall, so design-flood discharges determined with data for undeveloped or natural conditions do not reflect discharges expected with developed conditions. (Of course, facilities must be designed for these developed conditions.)
- In many cases, flood hydrographs are required for design. The statistical analysis procedure does not provide these.

Consequently, an alternative analysis procedure is required.

Fortunately, the density of precipitation gauges in the County is sufficient to permit fitting a statistical model of precipitation depths, from which storms of specified return period can be predicted. From these storms, discharge can be estimated with a rainfall-runoff-routing model. If the median or average values of all model parameters are used, the return period of the discharge computed from precipitation should equal approximately the return period of the precipitation (Pilgrim and Cordery,

---

<sup>5</sup> The name of Interagency Advisory Committee on Water Data is now the Advisory Committee on Water Data.

1975). This then provides the information needed for stormwater management.

## **2.2 Overview**

### **2.2.1 Analysis Steps**

In summary, the steps required to define design discharge from precipitation in El Dorado County are as follows:

1. Define the locations at which design quantiles or hydrographs are required and identify the corresponding catchments.
2. Determine the present and projected land uses and other pertinent physical characteristics for each catchment.
3. Determine the return periods (risk) for which runoff hydrograph or peak discharge is to be computed. (See Section 1 for El Dorado County requirements.)
4. Select the appropriate hydrological procedure for computing the required runoff hydrograph or peak discharge. (See Section 2.2.1 for analysis requirements.)
5. Define the design-storm characteristics required by the hydrological procedures. (See Section 2.3.)
6. Estimate model parameters and compute runoff for the design event. (See Section 2.4 or 2.5, depending on the stormwater-runoff computation method selected.)
7. If necessary, add baseflow, and route and combine computed hydrographs. (See Section 2.6 and 2.7 for guidelines.)
8. Assess the reasonableness of the computed runoff hydrograph or peak discharge. (See Section 2.8.)
9. Evaluate the significance of the computed discharges. Although the County sets minimum design standards, the engineer should examine the marginal cost of designing for a greater level of protection. In some cases, the level of protection can be increased significantly with a modest increase in cost. Further, the design levels admittedly do not represent the worst case; they represent a compromise between cost and risk. If a potential exists for catastrophic losses, the engineer

should evaluate the consequences of events larger than the specified design events.

### **2.2.2 Appropriate Stormwater-runoff Computation Method**

To estimate stormwater discharge peaks or hydrographs, the engineer must account for surface runoff, routing, and storage. El Dorado County accepts either of two approaches to this, depending on study needs and catchment characteristics. The first approach, described in section 2.4, yields a runoff hydrograph using a simple model of infiltration and interception plus a unit-hydrograph mode. The second approach, described in Section 2.5, yields only an estimate of peak discharge as a linear function of rainfall intensity.

In principle, the hydrograph method can be used for analysis and design of drainage facilities for any catchment in the County. However, if a catchment is small, if the hydrological processes in the catchment are relatively simple, and if runoff volume is not a concern, then a peak-only model may be adequate. This would be true, for example, for design of a culvert to carry runoff from a small industrial site in which most rain that falls will run off without ponding, with minor storage or energy loss in channels. In that case, a peak-only model would provide adequate information to design the culvert.

As a rule-of-thumb, use of the peak-only method is restricted to catchments with area less than 100 acres. In any analyses in which the peak-only model is used, the design engineer must determine and demonstrate that the model is, in fact, appropriate. If one or more of the following conditions are true, the peak-only method *cannot* be used unless the engineer demonstrates conclusively that the effects of that condition are negligible:

- Natural or man-made ponding of stormwater in the catchment affects peak discharge;
- Design and operation of larger drainage facilities is required;
- Routing is required to model adequately the runoff because of the impact of channel flow;
- The catchment is large enough that design-storm rainfall depths vary significantly across the catchment; or

- Differences in catchment response to rainfall cause variations in timing of peaks, so hydrographs must be computed to evaluate the impact of coincident peaks.

### **2.2.3 Exceptions**

Although Section 2 describes acceptable methods and procedures for stormwater-runoff computation, El Dorado County concurs with Loague and Freeze (1985) that

*...hydrologic modeling is more an art than a science...The usefulness of the results depends in large measure on the talents and experience of the hydrologist...It is unlikely that the results of an objective analysis of modeling methods...can ever be substituted for the subjective talents of an experienced modeler.*

Accordingly, the County is open to use of procedures not described herein, if the engineer can demonstrate that those procedures reproduce observed events and provide reasonable results.

### **2.3 Design Precipitation**

Both stormwater-runoff computation methods accepted by the County estimate design discharge from precipitation. This precipitation is defined either as a design storm (for the hydrograph method) or as a design intensity (for the peak method). Steps in determining the design storm precipitation are as follows:

1. Select appropriate storm duration. (See Section 2.3.1.)
2. Determine the precipitation depth for the storm duration. (See Section 2.3.2.)
3. If necessary, correct the depth for area and snowmelt.
4. If the hydrograph method is used, use the storm depth and the design-storm temporal distribution to determine the design-storm hyetograph. (See Section 2.3.3.) Otherwise, determine the design precipitation intensity = depth/duration.

### 2.3.1 Design-storm Duration

The design-storm duration appropriate for stormwater runoff computation depends on the hydrologic-response characteristics of the catchment. The duration selected must be sufficiently long that the entire catchment contributes to discharge at the outlet, taking into account overland and channel flow and storage in the catchment.

If the peak-only method is used, the presumption is that most flow is overland. In that case, the storm duration should equal the time of concentration,  $t_c$ , of the catchment. Section 2.4.2 provides guidance for estimation of  $t_c$ . For convenience with the depth-duration-frequency relationship used in El Dorado County, the duration may be rounded up to 5, 10, 15, 30, or 60 minutes. If  $t_c$  exceeds 60 minutes, natural or man-made ponding of stormwater in the catchment almost certainly affects peak discharge, and routing likely is required to model adequately the runoff because of the impact of discharge in channels. In that case, the hydrograph method, rather than peak-only method, should be used.

If the hydrograph method is used, selection of storm duration is more difficult. Regarding this, the Hydrologic Engineering Center (1982) suggests that:

- *...a minimum storm duration should be selected at least equal to, and preferably well in excess of, the estimated travel time (time of concentration) at the downstream-most point of interest...*
- *This selected duration should be increased considerably if total volume of runoff as well as peak discharge is of importance in the study.*
- *Reservoir studies require long-duration events for full assessment of the reservoir flood storage needed.*

With these guidelines in mind, and for consistency with common practice (including practices of the USDA Natural Resources Conservation Service<sup>6</sup>), the following storm durations are required:

1. For drainage planning with the hydrograph method, a 24-hour storm;
2. For regional detention basin design, a longer duration historical storm, selected with concurrence of El Dorado County.

The engineer must identify clearly the duration of the design storm and justify its selection.

---

<sup>6</sup> The USDA Natural Resources Conservation Service (NRCS) was formerly known as the Soil Conservation Service (SCS).

### 2.3.2 Design-storm Depth

Rainfall depth-duration-frequency relationships for El Dorado County were developed by Jim Goodridge (1989, updated 2008). In those relationships, depth for a specified duration and frequency is specified as a function of mean annual rainfall.

Steps necessary to estimate the design storm depth for any catchment from the depth-duration-frequency relationships are as follows:

1. Locate the catchment of interest on the El Dorado County mean annual rainfall map, and determine from the map the mean annual rainfall for the catchment. This map is included in Appendix 2.2.
2. For the selected storm duration and frequency, find the appropriate depth estimated by Goodridge. Table 2.3.1 shows the depths for the 10-yr and 100-yr events for 24-hr storms for selected mean annual rainfall values. Depths for other durations, frequencies, and mean annual rainfall values are available in the Goodridge report and are shown in tables in Appendix 2.2.
3. If the catchment is sufficiently large or is oriented in such a fashion that mean annual rainfall varies significantly within the catchment, repeat steps 2 and 3 for a grid of many points over the catchment. Then compute an average of the point values.
4. Adjust the design depth to an areal average depth.
5. If the design storm is likely to fall on a snowpack, estimate and add snowmelt.

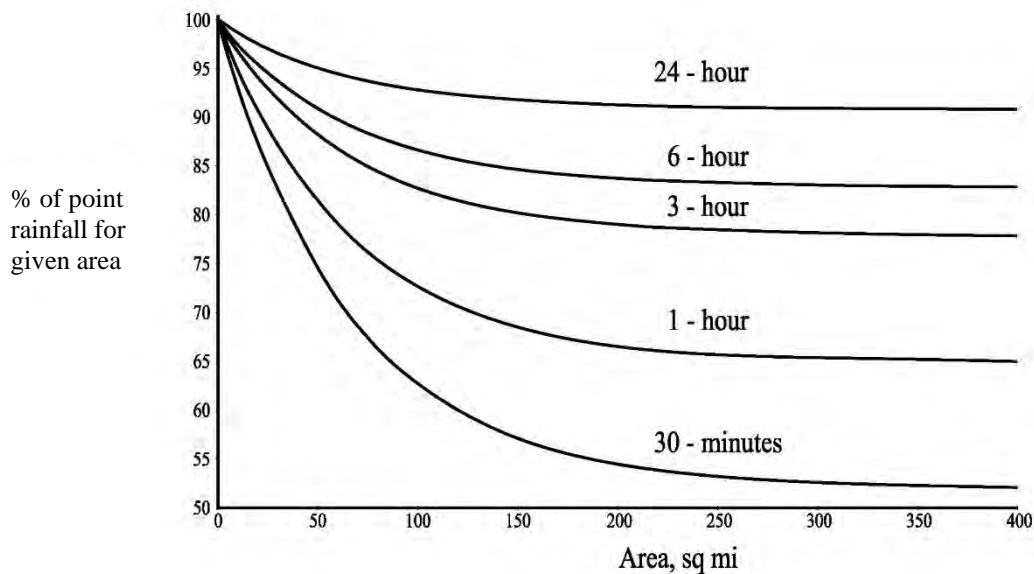
**Table 2.3.1 10-yr and 100-yr 24-hr Design Depths  
as a Function of Mean Annual Rainfall  
(Source: Goodridge, 2008)**

| Mean annual<br>rainfall, in in.<br>(1) | 10-yr, 24-hr<br>depth, in in.<br>(3) | 100-yr, 24-hr<br>depth, in in.<br>(5) |
|--|--------------------------------------|---------------------------------------|
| 20                                     | 2.58                                 | 3.65                                  |
| 30                                     | 3.88                                 | 5.48                                  |
| 40                                     | 5.17                                 | 7.31                                  |
| 50                                     | 6.46                                 | 9.13                                  |
| 60                                     | 7.75                                 | 10.96                                 |
| 70                                     | 9.04                                 | 12.79                                 |



Suppose, for illustration, that the catchment of interest is a 5 sq mi catchment near Rescue, CA. The design storm selected is a 100-yr, 24-hr event. From the map in Appendix 2.2, the mean annual rainfall is estimated to be 30 in. From Table 2.3.1 (or the more detailed tables in Appendix 2.2), the 100-yr, 24-hr depth is found to be 5.48 in. The average intensity for the storm is  $5.48 \text{ in./24 hr} = 0.23 \text{ in./hr}$ .

Models for estimating runoff due to rainfall assume a uniform spatial distribution of rainfall over the catchment. However, intense rainfall is unlikely to be distributed uniformly over a large catchment; for a specified frequency and duration, the average rainfall depth over an area is less than the depth measured at a gauge. To account for this, the U.S. Weather Bureau (1958) derived, from the means of annual series of point and areal values for several dense, recording-raingauge networks, factors by which point depths are to be reduced to yield areal-average depths. The factors, expressed as a percentage of point depth, are a function of area and duration, as shown in Fig. 2.3.1. These depth-reduction factors are to be used for analysis of runoff from large catchments in El Dorado County. However, in accordance with the recommendation of the World Meteorological Organization (1983), point values are to be used without reduction for areas up to  $25\text{km}^2$  (6000 acres). Further, in accordance with the recommendation of the Hydrologic Engineering Center (1982), no adjustment should be made for durations less than 30 minutes, because such duration corresponds to a short time of concentration. A short time of concentration, in turn, is indicative that the catchment must be relatively small, so no adjustment is necessary.



**FIG. 2.3.1 Depth-area Adjustment**  
(Source: U.S. Weather Bureau, 1958)

For catchments subject to snow accumulation, melt due to rainfall can contribute significantly to runoff. To account for this, an appropriate adjustment to design storm precipitation should be made. The engineer should refer to appropriate publications of the USACE, the NRCS, and the World Meteorological Organization, and should coordinate with the County to select this adjustment.

### ***2.3.3 Design-storm Temporal Distribution***

If a design-storm runoff hydrograph is to be computed, the temporal distribution of the design depth must be specified. For El Dorado County, NRCS type IA and type I temporal distributions are used for the 24-hr storm, depending on the location of the catchment of interest within the County.

According to NRCS California Bulletin no. CA210-4-6 (March 11, 1994), the type IA distribution best represents storm patterns likely to occur in areas in which the ratio of the 6-hr 1%-chance depth to the 24-hr 1%-chance depth ( $P_6/P_{24}$ ) is less than 0.518, and the type I distribution best represents storm patterns likely to occur in areas in which  $P_6/P_{24}$  is between 0.518 and 0.640. To simplify identification of the appropriate storm type using the criteria, El Dorado County staff collected point rainfall depths from the analyses by Goodridge for gauges bracketing the County line, determined  $P_6/P_{24}$  for each, and conducted a linear regression analysis with ( $P_6/P_{24}$ ) as the dependent variable and elevation as the independent (letter from DOT to NRCS; August 1, 1994). This indicated that  $P_6/P_{24}$  is 0.518 at 1,640 ft elevation. Thus with concurrence of the NRCS (NRCS file memo 210-18; September 13, 1994), El Dorado County requires uses of the NRCS type I distribution for catchments with elevation less than 1,640 ft and use of the type IA distribution for those above 1,640 ft. Of course, this boundary at 1,640 ft is hypothetical; it simply represents the approximate location at which predominate storm types shift. If portions of the catchment are both above and below 1,640 ft, the implication is that neither storm is significantly more likely. In that case, the engineer should either (1) exercise reasonable judgment to select one of the distributions and explain how it was selected, or (2) subdivide the catchment and use the appropriate distribution for each subdivision.

The NRCS temporal distributions are shown in Table 2.3.2. To derive the required 24-hr storm depths, each fraction in cols. 2 and 5 for the type IA or in cols. 3 and 6 for the type I storm is multiplied by the adjusted 24-hr rainfall total. This yields cumulative rainfall depth, in inches. The cumulative depth at times not shown in the table can be found with linear interpolation. Incremental rainfall can be computed by computing differences in successive values.

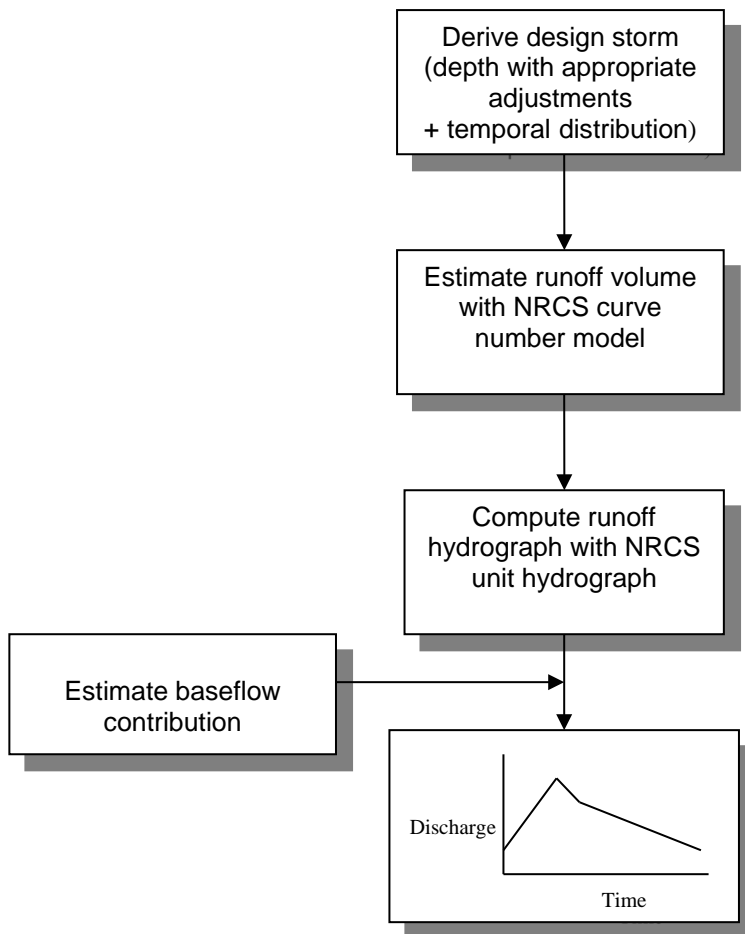
For example, for Rescue, CA the 24-hr 100-yr depth is 5.48 in. The elevation at Rescue is less than 1,640 ft, so the type I distribution will be used. The rainfall fraction shown for 0.5 hr is 0.008, so the cumulative rainfall after 0.5 hr is  $(0.008)(5.48) = 0.04$  in. The fraction shown for 1.0 hr is 0.017, so after 1hr, the cumulative rainfall will be  $(0.017)(5.48) = 0.09$  in. The incremental rainfall from time 0.0 hr to 0.5 hr is  $(0.04 - 0.00) = 0.04$  in, and the incremental rainfall from time 0.5 hr to 1.0 hr is  $(0.10 - 0.04) = 0.06$  in. These calculations can be continued to define the incremental rainfall for subsequent 0.5 hr intervals.

**Table 2.3.2 NRCS Type IA and I 24-hr Rainfall Distributions**  
(Source: NRCS TR-55 program files)

| Time, hrs<br>(1) | Fraction of 24-hr total |               | Time, hrs<br>(4) | Fraction of 24-hr total |               |
|------------------|-------------------------|---------------|------------------|-------------------------|---------------|
|                  | Type IA<br>(2)          | Type I<br>(3) |                  | Type IA<br>(5)          | Type I<br>(6) |
| 0.0              | 0.000                   | 0.000         | 12.5             | 0.683                   | 0.706         |
| 0.5              | 0.010                   | 0.008         | 13.0             | 0.701                   | 0.728         |
| 1.0              | 0.022                   | 0.017         | 13.5             | 0.719                   | 0.748         |
| 1.5              | 0.036                   | 0.026         | 14.0             | 0.736                   | 0.766         |
| 2.0              | 0.051                   | 0.035         | 14.5             | 0.753                   | 0.783         |
| 2.5              | 0.067                   | 0.045         | 15.0             | 0.769                   | 0.799         |
| 3.0              | 0.083                   | 0.055         | 15.5             | 0.785                   | 0.815         |
| 3.5              | 0.099                   | 0.065         | 16.0             | 0.800                   | 0.830         |
| 4.0              | 0.116                   | 0.076         | 16.5             | 0.815                   | 0.844         |
| 4.5              | 0.135                   | 0.087         | 17.0             | 0.830                   | 0.857         |
| 5.0              | 0.156                   | 0.099         | 17.5             | 0.844                   | 0.870         |
| 5.5              | 0.179                   | 0.112         | 18.0             | 0.858                   | 0.882         |
| 6.0              | 0.204                   | 0.126         | 18.5             | 0.871                   | 0.893         |
| 6.5              | 0.233                   | 0.140         | 19.0             | 0.884                   | 0.905         |
| 7.0              | 0.268                   | 0.156         | 19.5             | 0.896                   | 0.916         |
| 7.5              | 0.310                   | 0.174         | 20.0             | 0.908                   | 0.926         |
| 8.0              | 0.425                   | 0.194         | 20.5             | 0.920                   | 0.936         |
| 8.5              | 0.480                   | 0.219         | 21.0             | 0.932                   | 0.946         |
| 9.0              | 0.520                   | 0.254         | 21.5             | 0.944                   | 0.956         |
| 9.5              | 0.550                   | 0.303         | 22.0             | 0.956                   | 0.965         |
| 10.0             | 0.577                   | 0.515         | 22.5             | 0.967                   | 0.974         |
| 10.5             | 0.601                   | 0.583         | 23.0             | 0.978                   | 0.983         |
| 11.0             | 0.623                   | 0.624         | 23.5             | 0.989                   | 0.992         |
| 11.5             | 0.644                   | 0.655         | 24.0             | 1.000                   | 1.000         |
| 12.0             | 0.664                   | 0.682         |                  |                         |               |

## **2.4 Hydrograph Method**

Stormwater runoff hydrographs are determined with the procedure illustrated in Fig. 2.4.1. The NRCS curve number and unit hydrograph models are described in detail in section 4 or the *National Engineering Handbook* (1972), commonly referred to as *NEH-4*, and in *NRCS's Urban Hydrology for Small Watersheds Technical Release 55* (1986), commonly referred to as *TR-55*. For convenience, the methods are summarized here. However, the NRCS documents are considered the authoritative references on model application, notwithstanding any guidance provided herein.



**FIG. 2.4.1 Runoff Computation Procedure**

### 2.4.1 Runoff Volume

Stormwater runoff volumes for hydrograph computations are estimated with the NRCS curve number (CN) model. This model estimates the volume of direct runoff per unit area,  $P_e$ , as:

$$P_e = \frac{(P - I_a)^2}{P - I_a + S} \quad (\text{Eq. 2.4.1})$$

in which  $P$  = depth of rainfall;  $I_a$  = initial abstraction before ponding; and  $S$  = potential maximum depth of water retained in the catchment. This equation applies if  $(P - I_a) > 0$ ; otherwise the rainfall is “lost” to the initial abstraction.  $P_e$  is sometimes referred to as the rainfall excess; it is the rainfall that is neither retained on the surface nor infiltrated into the soil.

From data for gauged catchments, the NRCS found that, on the average, the initial abstraction and maximum retention were related as:

$$I_a = 0.2S \quad (\text{Eq. 2.4.2})$$

Also from analysis of gauged data, the NRCS found that maximum retention could be predicted as a function of antecedent moisture, land-cover type / hydrologic treatment, and soil type. The predictive relationship uses an intermediate variable, called the curve number (CN) that is related to retention as:

$$S = \frac{1000}{CN} - 10 \quad (\text{Eq. 2.4.3})$$

The NRCS has determined and tabulated CN values for various land uses on the various soil types for average antecedent moisture conditions. CN tables are included in *NEH-4* and in *TR-55*. For convenience, the tables are reproduced and included as Appendix 2.3. For simplicity in these tables, the NRCS categorized soils as those with high infiltration rates and, hence, low runoff potential (hydrologic soil group A); those with moderate infiltration rates when thoroughly wetted (hydrologic soil group B); those with low infiltration rates when thoroughly wetted (hydrologic soil group C); and those with very low infiltration rates and high runoff potential (hydrologic soil group D).

For a catchment that consists of a variety of land uses and soil types, a CN is computed for each combination, and a composite CN is computed as the spatially-weighted average.

To compute a runoff hydrograph, the temporal distribution of rainfall excess must be estimated. This is accomplished by computing first the cumulative rainfall depth for the design storm, as demonstrated in Section 2.3. Equation 2.4.1 is then solved to estimate cumulative excess at each time step. Differences in successive cumulative excess values are the incremental excess values. These are used to compute the runoff hydrograph.

For illustration, the calculations for the first few hours of a 24-hr storm are shown in Table 2.4.1. These computations are for the Rescue, CA example, using CN=70. Col. 2 shows the cumulative rainfall depths from the 24-hr 100-yr design storm, with a type 1 distribution. The maximum retention, according to Equation 2.4.3, is 4.29 in., and the initial abstraction, according to Equation 2.4.2, is 0.86 in. Consequently, until the cumulative rainfall exceeds this initial abstraction (sometime between 6.5 and 7.0 hrs), the excess rainfall (shown in col. 3) is zero. Thereafter, the excess is the value computed with Equation 2.4.1. The values in col. 4 are the differences in successive values in col. 3. These incremental excess values are necessary for computation of the runoff hydrograph.

**Table 2.4.1 Rainfall Excess Computation Example**

| Time, hr<br>(1) | Cumulative<br>rainfall, in.<br>(2) | Cumulative<br>excess, in.<br>(3) | Incremental<br>excess, in.<br>(4) |
|-----------------|------------------------------------|----------------------------------|-----------------------------------|
| 0.0             | 0.00                               | 0.00                             | 0.00                              |
| 0.5             | 0.05                               | 0.00                             | 0.00                              |
| 1.0             | 0.10                               | 0.00                             | 0.00                              |
| 1.5             | 0.15                               | 0.00                             | 0.00                              |
| 2.0             | 0.20                               | 0.00                             | 0.00                              |
| 2.5             | 0.26                               | 0.00                             | 0.00                              |
| 3.0             | 0.32                               | 0.00                             | 0.00                              |
| 3.5             | 0.38                               | 0.00                             | 0.00                              |
| 4.0             | 0.44                               | 0.00                             | 0.00                              |
| 4.5             | 0.51                               | 0.00                             | 0.00                              |
| 5.0             | 0.58                               | 0.00                             | 0.00                              |
| 5.5             | 0.65                               | 0.00                             | 0.00                              |
| 6.0             | 0.73                               | 0.00                             | 0.00                              |
| 6.5             | 0.81                               | 0.00                             | 0.00                              |
| 7.0             | 0.91                               | 0.00                             | 0.00                              |
| 7.5             | 1.01                               | 0.01                             | 0.01                              |
| 8.0             | 1.13                               | 0.02                             | 0.01                              |
| 8.5             | 1.27                               | 0.04                             | 0.02                              |
| 9.0             | 1.48                               | 0.08                             | 0.04                              |
| 9.5             | 1.76                               | 0.16                             | 0.08                              |
| etc.            |                                    |                                  |                                   |

### 2.4.2 Runoff Hydrograph

A runoff hydrograph can be computed from rainfall excess with the following equation:

$$Q_n = \sum_{m=1}^{n, n \leq M} P_m U_{n-m+1} \quad (\text{Eq. 2.4.4})$$

In which  $Q_n$  = hydrograph ordinate  $n$  (at time  $n\Delta t$ );  $P_m$  = rainfall excess ordinate  $m$  (in time interval  $m\Delta t$ );  $\Delta t$  = computation time interval;  $U_{n-m+1}$  = unit hydrograph (UH) ordinate  $(n-m+1)$  (at time  $(n-m+1)\Delta t$ ); and  $M$  = number of periods of excess rainfall (of duration  $\Delta t$ ). For El Dorado County, the NRCS unit hydrograph UH is used with Equation 2.4.4. This is a dimensionless UH in which the ordinate at any time is defined as a fraction of the UH peak discharge. The UH ordinates, in dimensionless format, are given in Table 2.4.2.

**Table 2.4.2 NRCS Dimensionless UH**  
(Source: NEH-4, 1972)

| % time to UH peak (% $T_p$ )<br>(1) | % UH peak (% $q_p$ )<br>(2) |  | % time to UH peak (% $T_p$ )<br>(3) | % UH peak (% $q_p$ )<br>(4) |
|-------------------------------------|-----------------------------|--|-------------------------------------|-----------------------------|
| 0.0                                 | 0.00                        |  | 1.7                                 | 0.46                        |
| 0.1                                 | 0.03                        |  | 1.8                                 | 0.39                        |
| 0.2                                 | 0.10                        |  | 1.9                                 | 0.33                        |
| 0.3                                 | 0.19                        |  | 2.0                                 | 0.28                        |
| 0.4                                 | 0.31                        |  | 2.2                                 | 0.207                       |
| 0.5                                 | 0.47                        |  | 2.4                                 | 0.147                       |
| 0.6                                 | 0.66                        |  | 2.6                                 | 0.107                       |
| 0.7                                 | 0.82                        |  | 2.8                                 | 0.077                       |
| 0.8                                 | 0.93                        |  | 3.0                                 | 0.055                       |
| 0.9                                 | 0.99                        |  | 3.2                                 | 0.04                        |
| 1.0                                 | 1.00                        |  | 3.4                                 | 0.029                       |
| 1.1                                 | 0.99                        |  | 3.6                                 | 0.021                       |
| 1.2                                 | 0.93                        |  | 3.8                                 | 0.015                       |
| 1.3                                 | 0.86                        |  | 4.0                                 | 0.011                       |
| 1.4                                 | 0.78                        |  | 4.5                                 | 0.005                       |
| 1.5                                 | 0.68                        |  | 5.0                                 | 0.00                        |
| 1.6                                 | 0.56                        |  |                                     |                             |

The UH peak is given by

$$q_p = \frac{484A}{T_p} \quad (\text{Eq. 2.4.5})$$

in which  $q_p$  = UH peak, in cfs;  $A$  = catchment area, in sq mi; and  $T_p$  = time to UH peak, in hr. This time to peak is given by

$$T_p = \frac{\Delta D}{2} + L \quad (\text{Eq. 2.4.6})$$

in which  $\Delta D$  = duration of unit rainfall excess, in hr; and  $L$  = catchment lag time, in hr. According to the *NEH-4*, for average conditions this lag can be estimated as 60%  $t_c$ .

According to *TR-55*, the time of concentration is the time it takes for runoff to travel from the hydraulically most distant part of the storm area to the watershed outlet or other point of reference downstream. It is generally understood as applying to surface runoff (NRCS, 1986). *TR-55* suggests that this flow time may be divided into three components: (1) sheet flow time, or time in which water flows overland in no clearly defined channel; (2) shallow flow time, in which water flows at shallow depths in rills or in streets or gutters; and (3) channel flow time, in which the runoff is in a clearly-defined channel. *TR-55* provides the following guidance for estimating these times:

*Sheet flow:* The travel time of sheet flow can be estimated with the following simplified solution to the kinematic-wave equations:

$$T_t = \frac{0.007(nL)^{0.8}}{(P_2)^{0.5}S^{0.4}} \quad (\text{Eq. 2.4.7})$$

in which  $T_t$  = sheet flow travel time, in hr;  $n$  = roughness coefficient for sheet flow (*not* to be confused with Manning's coefficient used in channel or pipe calculations);  $L$  = length of overland flow surface, in ft (< 300 ft);  $P_2$  = 2-yr, 24-hr rainfall depth, in inches; and  $S$  = land slope, in ft/ft. Roughness coefficients for sheet flow covering a variety of land uses are shown in Table 2.4.3. Roughness coefficients for additional land uses are tabulated in publications from the Hydrologic Engineering Center (1979, 1990).



*Shallow concentrated flow:* The velocity of shallow flow over an unpaved surface is estimated as:

$$V = 16.1345(s)^{0.5} \quad (\text{Eq. 2.4.8})$$

in which  $V$  = shallow-concentrated flow velocity, in ft/sec; and  $S_0$  = slope, in ft/ft. For flow over a paved surface, the velocity may be estimated as:

$$V = 20.3283(s)^{0.5} \quad (\text{Eq. 2.4.9})$$

In either case, the travel time is the flow path length divided by the velocity.

*Channel flow:* The velocity of flow in a clearly-defined channel is estimated with Manning's equation, assuming discharge equals the average annual value (2-yr event). If this discharge is unknown, the regression equation presented in Appendix 2.4 can be used to provide an estimate. The channel-flow travel time is the channel length divided by the velocity.

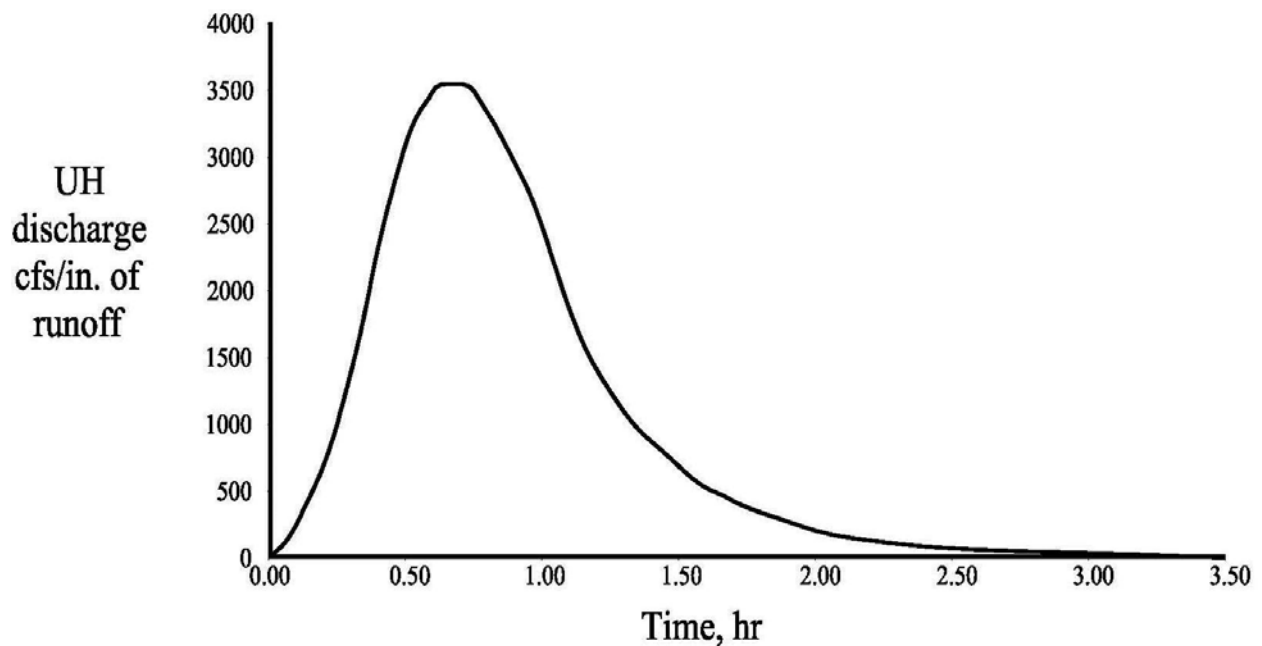
**Table 2.4.3 Roughness Coefficients for Sheet Flow**  
(Source: TR-55, 1986)

| Surface description<br>(1)                                | Sheet flow $n$<br>(2) |
|---|-----------------------|
| Smooth surfaces (concrete, asphalt, gravel, or bare soil) | 0.011                 |
| Fallow (no residue)                                       | 0.05                  |
| Cultivated soils:   |                       |
| Residue cover $\leq 20\%$                                 | 0.06                  |
| Residue cover $> 20\%$                                    | 0.17                  |
| Grass:  |                       |
| Short grass prairie                                       | 0.15                  |
| Dense grasses   | 0.24                  |
| Bermuda grass   | 0.41                  |
| Range (natural)   | 0.13                  |
| Woods:  |                       |
| Light underbrush  | 0.40                  |
| Dense underbrush  | 0.80                  |

When the various travel times are determined,  $t_c$  can be computed as the sum. The UH lag is estimated as 60%  $t_c$ , and Equation 2.4.5 is solved to

find the UH peak. In the solution of Equation 2.4.6, it is convenient to select  $\Delta D$  equal the computation time step. Then the resulting UH can be used directly with rainfall excess, which is computed with this same time step, to estimate the runoff hydrograph.

Fig. 2.4.2 shows the 10-min UH developed for an example 5-sq mi catchment in which  $t_c = 1$  hr. In that case, lag = 0.60 hr. Solving Equation 2.4.6 yields  $T_p = 0.683$  hr. Equation 2.4.5 yields  $q_p = 3541.5$  cfs/in. of excess rainfall. To develop the UH, values in cols. 1 and 3 of Table 2.4.2 are multiplied by  $T_p$ , and the values in cols. 2 and 4 are multiplied by  $q_p$ . To compute storm runoff, Equation 2.4.4 is solved with the UH and excess.



**FIG. 2.4.2 Example of 10-min UH for 5 sq mi Catchment**

## **2.5 Peak-discharge Method**

For cases in which a hydrograph is not required, peak discharge may be estimated as:

$$Q=CiA \quad (\text{Eq. 2.5.1})$$

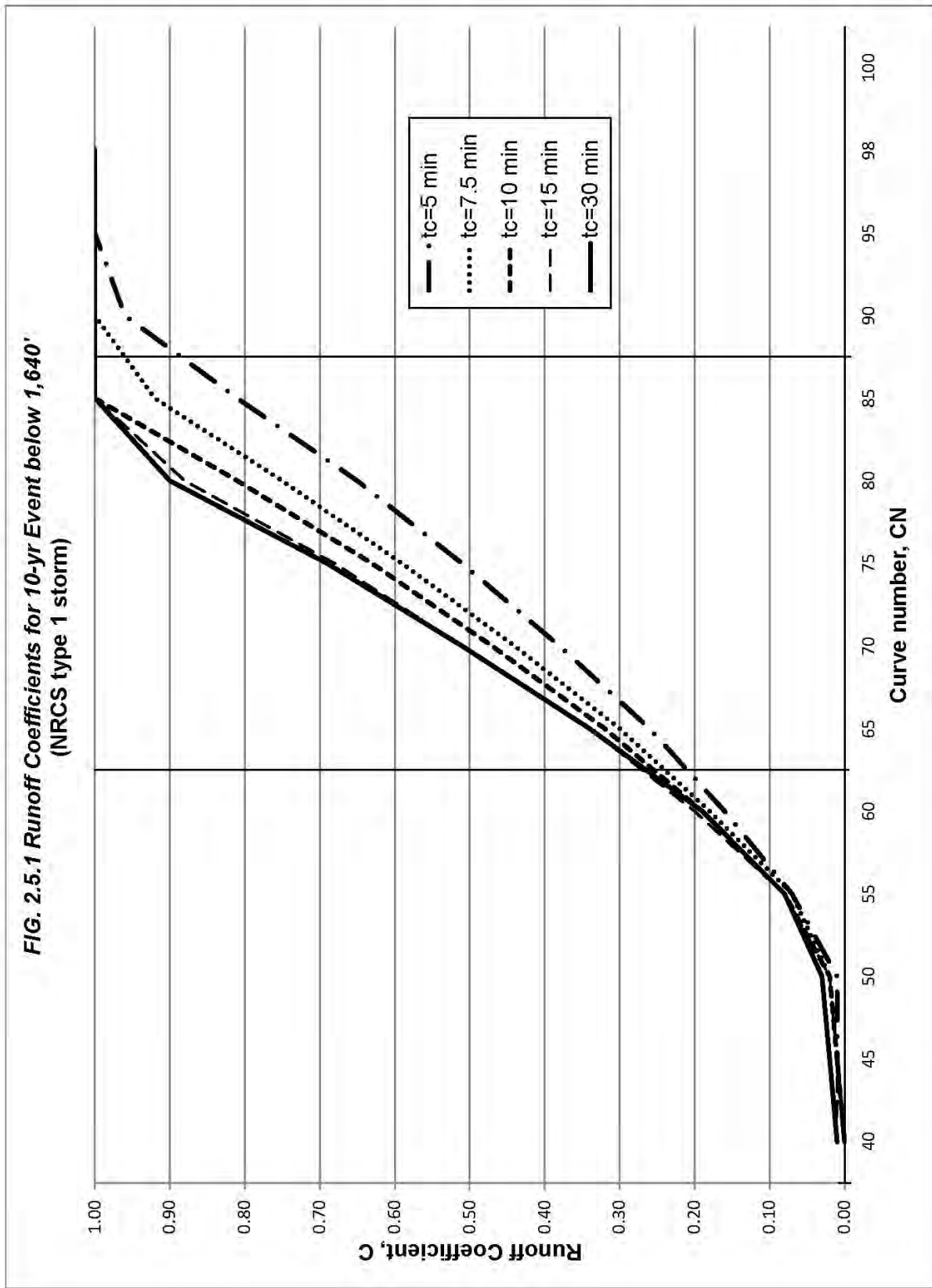
in which  $Q$  = the peak discharge, in cfs;  $i$  = design rainfall intensity, in in./hr, over a duration equal  $t_c$  for the catchment;  $A$  = catchment area, in acres; and  $C$  is a dimensionless runoff coefficient that accounts for the lumped effects of all processes that affect the transformation of rainfall to runoff.

Equation 2.5.1 commonly is known as a rational equation; use is common and guidance in use is readily available. (See, for example, WEF/ASCE, 1992). That guidance is not repeated here.

Use of the rational equation for stormwater peak computations for El Dorado County differs from what may be common practice in only two ways:

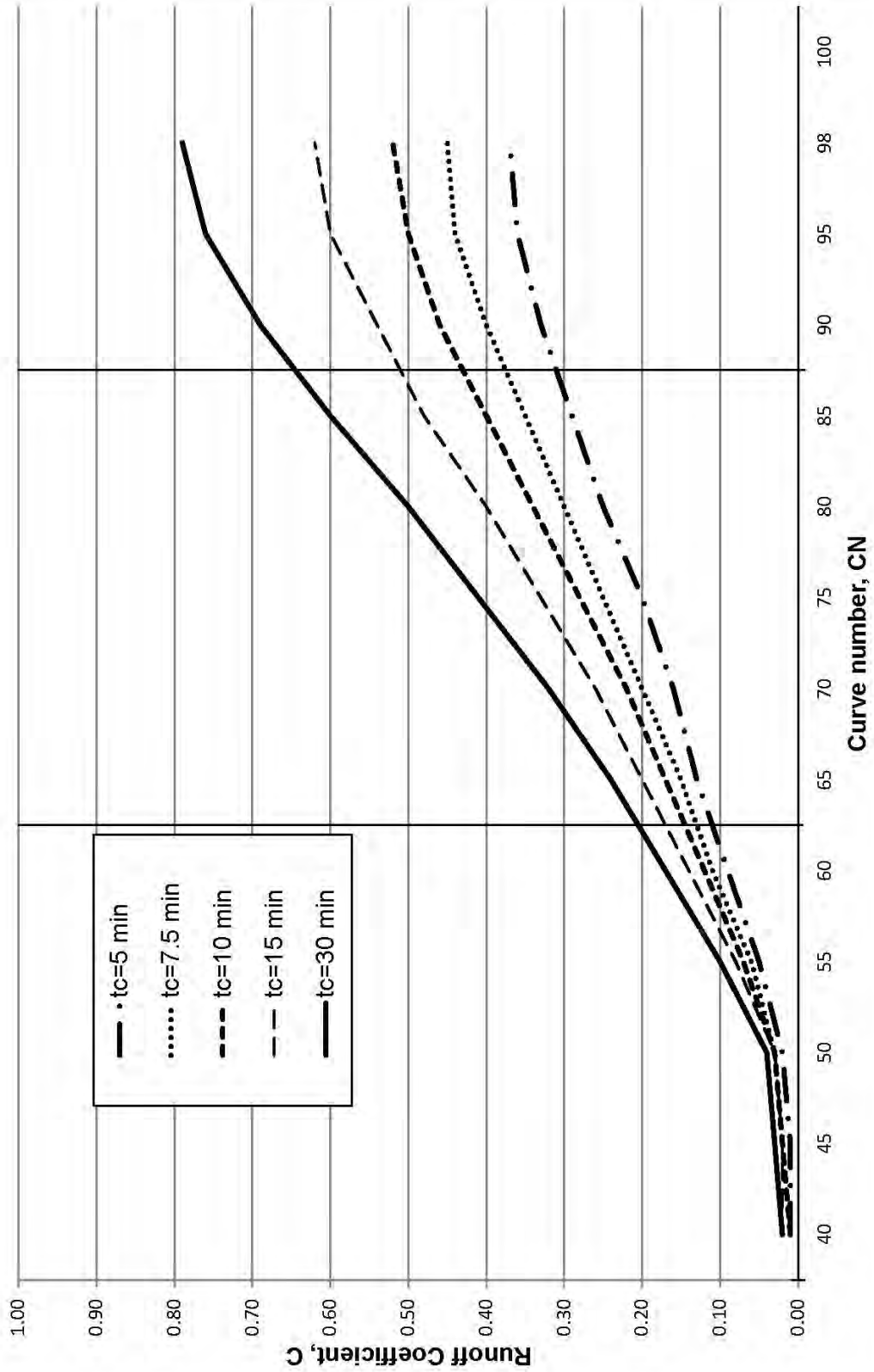
- *Computation of time of concentration.* The time of concentration must be estimated as described in Section 2.4, thus yielding consistent estimates regardless of the runoff computation method used.
- *Runoff coefficient.* To insure consistency with runoff peaks estimated with the hydrograph method,  $C$  is specified as a function of return period, time of concentration, land use, soil type, and storm type. Values of  $C$  for the 10-yr and 100-yr events above and below elevation 1,640 ft are shown in Figs. 2.5.1, 2.5.2, 2.5.3 and 2.5.4 respectively. These values were derived by the County following the procedure outlined by McKuen and Bondelid (1981). This procedure is based on the assumption that if, under the proper circumstances, the hydrograph method and the rational method are equally accurate and appropriate, both should yield the same quantile. In summary, the coefficients were found by computing the peak flow with the *TR-55* CN and UH hydrograph models, using a 24-hr storm with the appropriate rainfall depth for the selected return period. Then  $C$  is found using  $i$  = rainfall intensity for  $t_c$  in the rational equation.

Note that for consistency with the hydrograph method, these tables use CN as the index of land use/soil type. The value shown is a composite CN and is estimated as described in Section 2.4.1.

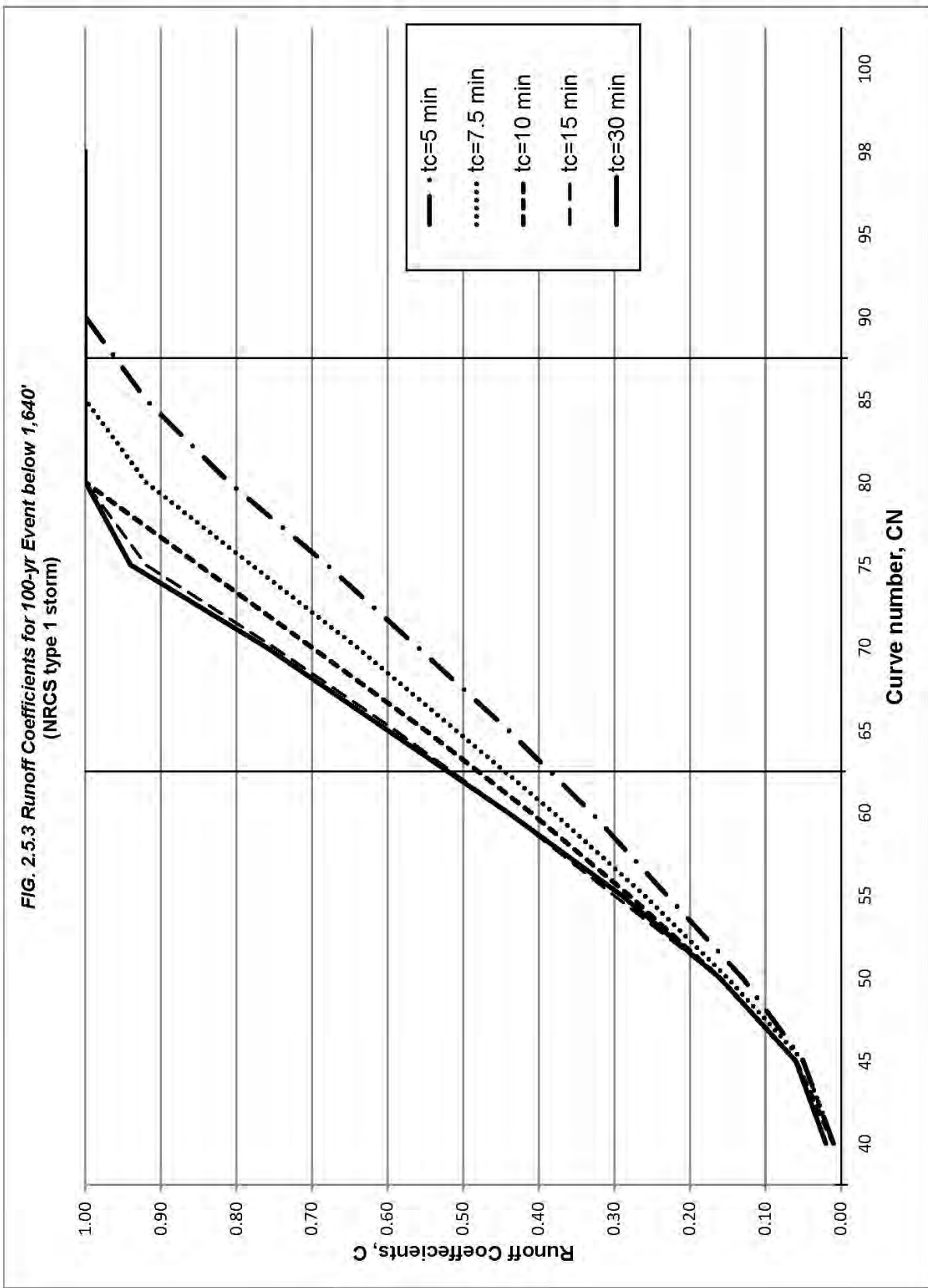


**FIG. 2.5.1 Runoff Coefficients for 10-yr Event below 1,640'**

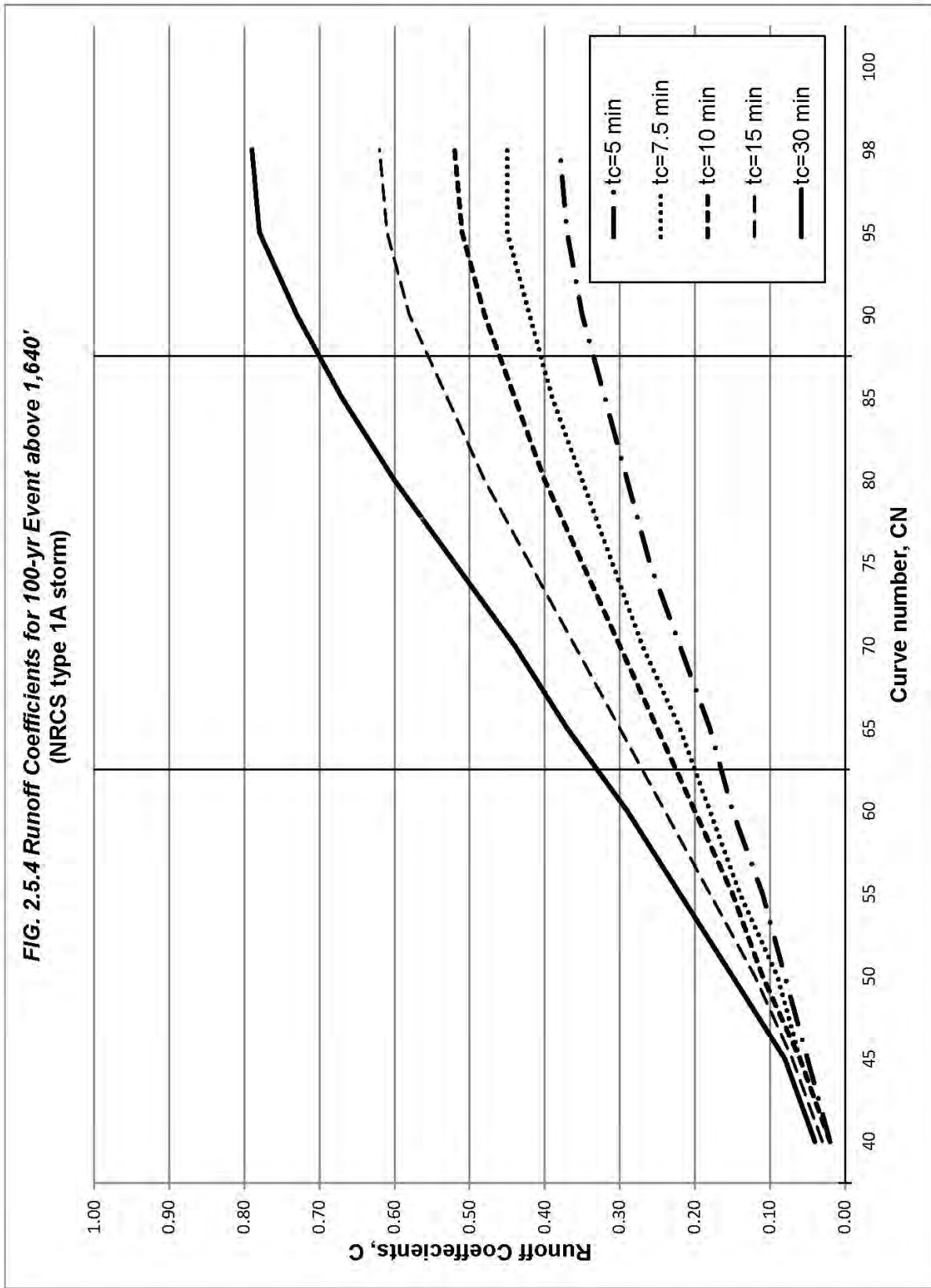
**FIG. 2.5.2 Runoff Coefficients for 10-yr Event above 1,640'  
(NRCS type 1A storm)**



**FIG. 2.5.2 Runoff Coefficients for 10-yr Event above 1,640'**



**FIG. 2.5.3 Runoff Coefficients for 100-yr Event below 1,640'**



**FIG. 2.5.4 Runoff Coefficients for 100-yr Event above 1,640'**

## **2.6 Baseflow**

Baseflow is "... drainage from ground water bodies whose water tables are above the levels of the streambeds" (Amerman and Naney, 1982). The source is precipitation (rain or snow) that has fallen, infiltrated, percolated, and traveled as interflow or groundwater flow to the channel.

Baseflow enters the stream channel via seepage and springs. Thus, if drainage in a catchment is primarily in lined channels or a pipe system, baseflow will be negligible and may be ignored. On the other hand, for unlined channels in El Dorado County, the engineer must account for baseflow, regardless of which method is used for runoff computation. The following methods of accounting for baseflow are acceptable:

- Determine and add a constant discharge. This is appropriate for an ephemeral stream. The rate may be estimated by inspection or by analysis of gauge data for similar catchments.
- Use an empirical model of baseflow, such as that in computer programs HEC-1, HEC-HMS or current industry standard. That model and others assume that drainage from ground water bodies decreases exponentially with time after rainfall stops; the flow rate at the beginning of a storm is a measure of the antecedent condition. Then, when the catchment is sufficiently charged with water during a storm, the runoff rate will again exhibit this same pattern of exponential decay as water drains from the catchment. Psomas and Associates (1991) proposed the parameters shown in Table 2.6.1 for this HEC-1 baseflow model, "... based on stream flow records in the Sierra Nevada foothills."

**Table 2.6.1 HEC-1 Baseflow-model Parameters**  
(Source: Psomas and Associates, 1991)

| Return period, in yrs | Initial flow, in cfs (STRTQ) | Ratio of flow at point of recession to flow 1 hr later (RTIOR) | Recession flow as fraction of runoff peak (QRCSN) |
|-----------------------|------------------------------|--|---|
| (1)                   | (2)                          | (3)  | (4)   |
| 2                     | 2                            | 1.05   | 0.1   |
| 5                     | 4                            | 1.05   | 0.1   |
| 10                    | 5                            | 1.05   | 0.1   |
| 25                    | 6                            | 1.05   | 0.1   |
| 50                    | 8                            | 1.05   | 0.1   |
| 100                   | 10                           | 1.05   | 0.1   |
| 200                   | 12                           | 1.05   | 0.1   |
| 500                   | 14                           | 1.05   | 0.1   |



El Dorado County recognizes that inclusion or omission of baseflow may have significant impact on stormwater facility design. For example, if baseflow is present but is mistakenly omitted, the volume of runoff may be underestimated, and a detention structure designed to control the 100-yr event may fail to do so. Consequently, it is the engineer's responsibility to properly account for this baseflow, regardless of the runoff-computation method used, and to explain the rationale for the accounting.

## **2.7 Complex Catchment Analysis**

For many analyses for stormwater management facilities in El Dorado County, catchments that contribute to discharge at the point of interest are sufficiently small that their response to rainfall is uniform throughout, and the impacts of channel flow are negligible. In that case, the catchment can be analyzed as a single unit, with a simple model of the transformation of rainfall to runoff.

If rainfall or hydrologic characteristics vary significantly in a catchment or if runoff hydrographs are required at intermediate locations, the engineer must subdivide the catchment for analysis. With this subdivision, runoff from individual subcatchments is computed with the hydrograph method, and the hydrographs are combined. If necessary, the hydrographs are routed before combining to account for channel-flow impacts.

### **2.7.1 Subcatchment Delineation**

Subcatchments may vary in size from a few acres to a few square miles, depending on the following:

- Locations at which significant quantities of water enter the drainage system;
- Locations at which discharge peaks and hydrographs should be determined to permit facility design or evaluation;
- Existing and projected drainage patterns;
- Existing and projected land uses;
- Physical characteristics of each subcatchment, including slopes, vegetation, soil types.

The engineer should provide maps delineating the subcatchments and showing clearly the drainage facilities.

### **2.7.2 Streamflow Routing**

Streamflow routing models account for the motion of flood flows in channels by solving the continuity and momentum equations. A number of alternative simplified solutions to these equations may be used for stormwater modeling, including:

- Muskingum-Cunge (diffusion-wave) model;
- Kinematic-wave model;
- Muskingum model;
- Storage (Modified Puls) model.

In addition to these, the equations may be solved with a dynamic-wave routing model. Such a model solves the “full” equations without simplification.

The appropriate routing model depends on the data available and the characteristics of the channel and the runoff hydrograph. A dynamic-wave model can be used in any case, but this level of complexity typically is not required. If the criteria shown in Table 2.7.1 are met, one of the simplified models can be used.

It is beyond the scope of this manual to provide specific guidance for parameter selection for all acceptable routing models. A hydrology text, such as *Applied Hydrology* (Chow, Maidment, and Mays, 1988), or pertinent publications of the USACE should be consulted.

**Table 2.7.1 Appropriate Simplified Routing Models  
(Adopted from USACE Engineering Manual 1110-2-1417, 1994)**

| Criteria<br>(1)   | OK to Use<br>(2)   | Don't Use<br>(3)                                 |
|---|--|--|
| Ungauged catchment  | Muskingum-Cunge,<br>kinematic wave                                 | Muskingum, Modified<br>Puls                      |
| Backwater impacts   | Modified Puls  | Muskingum-Cunge,<br>kinematic wave,<br>Muskingum |
| Overbank flow   | Muskingum-Cunge,<br>Modified Puls                                  | Muskingum  |
| $S_0 > (0.002) \&$<br>$T_{duration} S_0 V_{avg} / y_{avg} > 171$        | Muskingum-Cunge,<br>kinematic wave,<br>Muskingum, Modified<br>Puls | -  |
| $0.0004 < S_0 < 0.002 \&$<br>$T_{duration} S_0 V_{avg} / y_{avg} > 171$ | Muskingum-Cunge,<br>Muskingum, Modified<br>Puls                    | Kinematic wave                                   |
| $S_0 < 0.0004 \&$<br>$T_{duration} S_0 (g/y_{avg})^{1/2} > 30$          | Muskingum-Cunge  | Kinematic wave,<br>Muskingum, storage            |
| $S_0 < 0.0004 \&$<br>$T_{duration} S_0 (g/y_{avg})^{1/2} < 30$          | Dynamic-wave model   | Any simplified model                             |

**Note:**  $T_{duration}$  = hydrograph duration;  $S_0$  = friction slope (bed slope);  $y_{avg}$  = depth corresponding to average discharge conditions for hydrograph routed;  $v_{avg}$  = velocity corresponding to average discharge conditions for hydrograph routed;  $g$  = acceleration of gravity. Units for  $T_{duration}$ ,  $S_0$ ,  $y_{avg}$ ,  $v_{avg}$ , and  $g$  must be consistent. Muskingum-Cunge is one type of "Diffusion" Model.

For any study in which routing models are used, the engineer must provide the following information:

- Computations to demonstrate that the method selected satisfies the criteria of Table 2.7.1.
- If Muskingum or Modified Puls routing is used, a description of how parameters were estimated from gauged data.
- If the Muskingum-Cunge or kinematic wave model is used, a description of the location and geometric properties of any cross sections used. The cross sections selected should be representative of the channel reaches.
- Explanation of selection of Manning's  $n$  values, if required by the streamflow routing model. These values should be consistent with those in Section 6.

### ***2.7.3 Water-control Measures***

Water-control measures present in a catchment may alter significantly the catchment response. The engineer must identify these measures, both for existing and proposed conditions, and must evaluate their impact, which will be two-fold:

1. The measures will alter the flow time in the catchment, and thus may alter the time of concentration.
2. The measures will alter catchment design-storm runoff hydrographs.

Diversions and storage facilities, including natural ponds, should be modeled. Note that significant channel constrictions, such as bridges and culverts, may create an effect similar to a detention structure; they should be treated as such if this is so.

Diversions can be modeled with appropriate rating functions to account for the manner in which water is re-directed (HEC, 1990<sup>7</sup>). Storage facilities can be modeled with Modified Puls routing, as described in Section 5 of this manual.

The engineer must provide sufficient details to describe the water-control measures and to show how each is modeled.

### **2.8 Reasonableness**

The engineer must assess the reasonableness of design hydrographs or peaks computed with the procedures described herein, based on experience, on the experience of other engineers, and on information available on historical floods.

Estimated peaks and runoff volumes should be compared with those of equal return periods for similar catchments. In the absence of better information, computed peaks may be compared with results of the USGS regional regression equations (Waananen and Crippen, 1977<sup>8</sup>). For convenience, the appropriate equations for El Dorado County are included in Appendix 2.4. Any significant deviation from the peaks predicted with these regression equations may indicate an error in the analysis, so should be explained fully.

---

<sup>7</sup> The 1990 version of *HEC-1: Flood Hydrograph Package User's Manual* was updated in 1998. See Appendix 2.1.1 for updated references.

<sup>8</sup> The 1977 publication, "Magnitude and Frequency of Flood in California", has been replaced by a 2012 version titled, "Methods for Determining Magnitude and Frequency of Floods in California, Based on Data through Water Year 2006." See Appendix 2.1.1 for updated references.

## **2.9 Computer Programs**

El Dorado County does not require use of a computer program for the analyses prescribed herein. If the computations are completed according to the standards and guidelines presented herein, the engineer is free to use any appropriate tool.

Because of the complexity of the computations and the risk of blunders, El Dorado County endorses use of programs TR-55, HEC-1, or HEC-HMS for preparation of hydrology studies.

### ***2.9.1 NRCS Program TR-55***

The loss and unit hydrograph methods described herein are incorporated in computer program TR-55, which is available from the NRCS. Program input files that define the 24-hr storm depth-frequency relationship developed by Goodridge and described earlier in this section, are available for the program.

The TR-55 program does not include streamflow routing models. If routing is required, those computations must be performed with another program.

### ***2.9.2 USACE Program HEC-1 and HEC-HMS***

Program HEC-1, developed at the Hydrologic Engineering Center of the USACE, is a general purpose rainfall-runoff-routing program. It includes the loss, unit hydrograph, baseflow, and simplified routing models described herein. This program may be used for computations for drainage studies in El Dorado County.

Appendix 2.5 includes an example of an HEC-1 input file for computation of runoff from the small catchment used in previous examples.

HEC-1 is available from various vendors, from universities, and from other users. A list of these distributors is available from El Dorado County DOT. For additional information on HEC-1 use, the engineer is directed to the program's latest user's manual and to the publications of the HEC.

HEC-HMS (Hydrologic Modeling System) was developed in 1992 as a replacement for HEC-1 (2018). It is designed to simulate the complete hydrologic processes of dendritic watershed systems. Software downloads, user manuals, and information on training courses are available on the USACE's HEC website.

## **Appendix 2.1 References**

- Amerman, C.R. and Naney, J.W. (1982). *Hydrologic Modeling of Small Watersheds: Chapter 7, Subsurface Flow and Ground Water Systems*. American Society of Agricultural Engineers. St. Joseph, MI.
- Chow, V.T., Maidment, D.R., and Mays, L.W. (1988). *Applied Hydrology*. McGraw-Hill. New York, NY.
- Goodridge, J.D. (1989). *El Dorado County Design Rainfall*. Paradise, CA.
- Hydrologic Engineering Center (1979). "Introduction and Application of Kinematic Wave Routing Techniques Using HEC-1." *Training Document 10*. USACE. Davis, CA.
- Hydrologic Engineering Center (1982). "Hydrologic Analysis of Ungaged Watersheds Using HEC-1." *Training Document 15*. USACE. Davis, CA.
- Hydrologic Engineering Center (1990). *HEC-1: Flood Hydrograph Package User's Manual*. USACE. Davis, CA.
- Interagency Advisory Committee on Water Data (1982). "Guidelines for Determining Flood Flow Frequency." *Bulletin #17B*. USGS. Reston, VA.
- Loague, K.M. and Freeze, R.A. (1985). "A Comparison of Rainfall-Runoff Modeling Techniques on Small Upland Catchments." *Water Resources Research*. American Geophysical Union, Vol. 21 Issue 2, pp. 229-248.
- McKuen, R.H. and Bondelid, T.R. (1981). "Relationship Between Curve Number and Runoff Coefficient." *Journal of the Irrigation and Drainage Division*. ASCE. Volume 107(IR4), pp. 395-400.
- Pilgrim, D.H. and Cordery, I. (1975) "Rainfall Temporal Patterns for Design Floods." *Journal of the Hydraulics Division*. ASCE. Volume 101(HY1), Jan., 1975, 81-85.
- Psomas and Associates, (1991). *El Dorado County Drainage Manual (Draft)*. Sacramento, CA.
- Sauer, V.B., Thomas, W.O., Stricker, V.A., and Wilson, K.V. (1983). "Flood Characteristics of Urban Watersheds in the United States." *Water-Supply Paper 2207*. USGS. Alexandria, VA.

Soil Conservation Service (1972). *National Engineering Handbook, Section 4: Hydrology (NEH-4)*. USDA. Springfield, VA.

Soil Conservation Service (1986). "Urban Hydrology for Small Watersheds." *Technical Report 55*. USDA. Springfield, VA.

U.S. Army Corps of Engineers (1994). "Flood-Runoff Analysis." *Engineering Manual 1110-2-9021*. Office of Chief of Engineers. Washington, DC.

U.S. Weather Bureau (1958). "Rainfall Intensity-Frequency Regime." *USWB Technical Paper 29*. Washington, DC.

Waananen, A.O. and Crippen, J.R. (1977). "Magnitude and Frequency of Flood in California." *Water-Resources Investigations 77-21*. USGS. Washington, DC.

Water Environment Federation/American Society of Civil Engineers (1992). *Design and Construction of Urban Stormwater Management Systems*. New York, NY.

World Meteorological Organization (1983). "Guide to Hydrological Practices: Vol. II – Analysis, Forecasting and Other Applications." *WMO-No. 168*. Geneva, Switzerland.

*See Appendix 2.1.1 for updated references*

### **Appendix 2.1.1 Updated References**

Listed below are the updated versions of select references for this section or references that were absent from the original *Drainage Manual*. If an updated version was not available, the original version should be referenced.

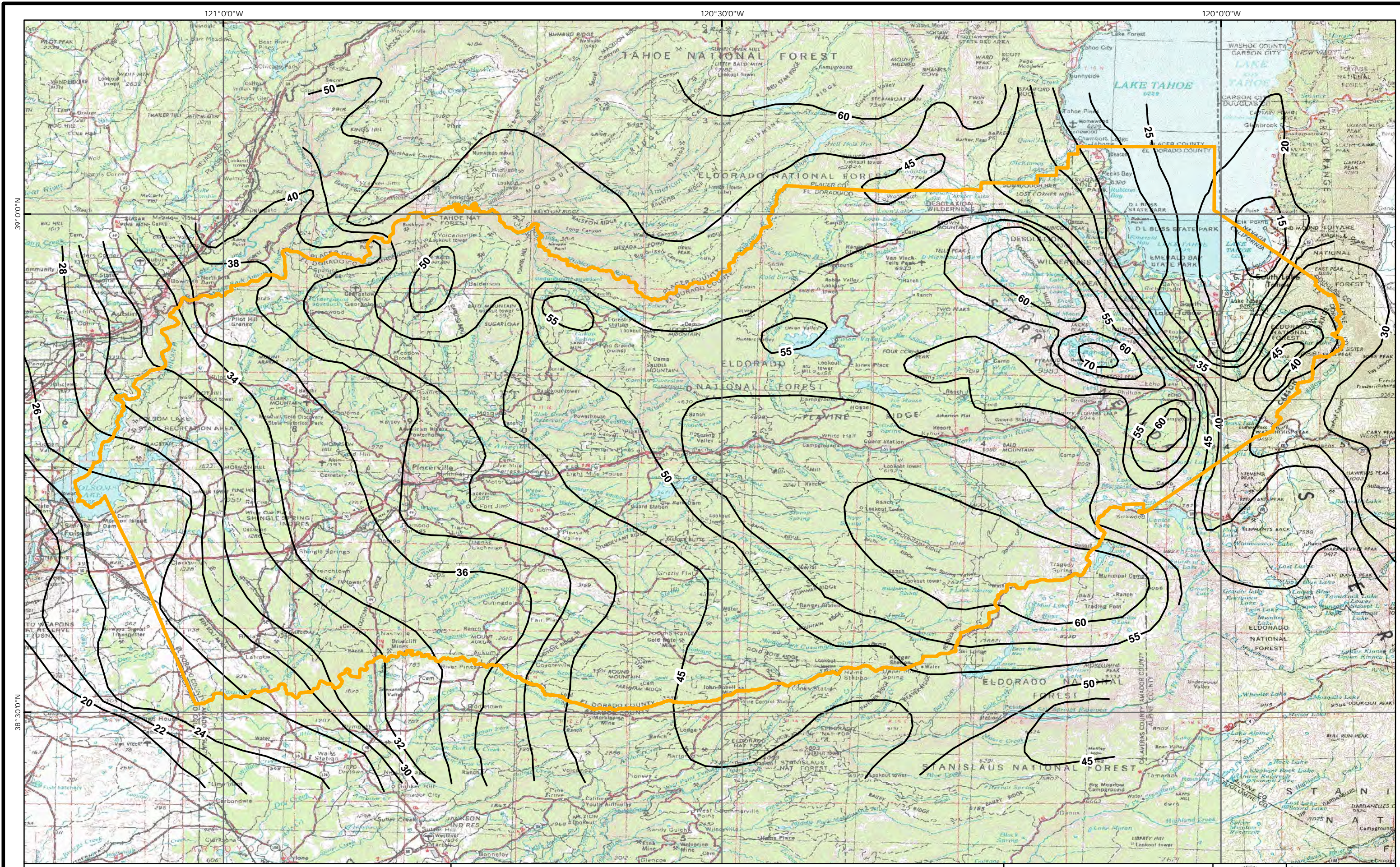
- Advisory Committee on Water Information (2018). "Guidelines for Determining Flood Flow Frequency." *Bulletin 17C*. Chapter 5 of Section B, *Surface Water Book 4, Hydrologic Analysis and Interpretation*. USGS and USACE. Reston, VA.
- American Society of Agricultural Engineers. (2017). *Guidelines for Calibrating, Validating, and Evaluating Hydrologic and Water Quality (h/wq) Models*. St. Joseph, MI.
- Barth, N. A., Gotvald, A. J., Parrett, C., and Veilleux, A.G. (2012). "Methods for Determining Magnitude and Frequency of Floods in California, Based on Data through Water Year 2006." *Scientific Investigations Report (SIR) 2012-5113*. USGS. Reston, VA.
- Goodridge, J.D. (2008). *El Dorado County Design Rainfall*. Paradise, CA.
- Hydrologic Engineering Center (1993). "Introduction and Application of Kinematic Wave Routing Techniques Using HEC-1." *Training Document 10*. USACE. Davis, CA.
- Hydrologic Engineering Center (1998). *HEC-1: Flood Hydrograph Package User's Manual*. USACE. Davis, CA.
- Hydrologic Engineering Center (2018). *HEC-HMS: Hydrologic Modeling System HEC-HMS User's Manual*. USACE. Davis, CA.
- Woodward, D. (1992). Presentation at ASCE Water Forum of the U.S. Department of Agriculture.
- World Meteorological Organization (2009). "Guide to Hydrological Practices: Vol. II – Management of Water Resources and Application of Hydrological Practices." *WMO-No. 168*. Geneva, Switzerland.



## **Appendix 2.2 El Dorado County Design Rainfall Data**

The map and tables in this appendix are from the report by Goodridge (1989, updated 2008). The map in Figure A2.2.1 shows mean annual rainfall throughout El Dorado County. Tables A2.2.1 through A2.2.7 show precipitation depth for durations of 5-, 10-, 15-, and 30-min, 1-, 2-, 3-, 6-, and 12-hr, and 1-, 2-, 3-, 4-, 5-, 6-, 8-, 10-, 15-, 20-, 30, 60-, and 365-days for return periods of 2-, 5-, 10-, 25-, 50-, 100-, and 1000-yrs, as a function of mean annual rainfall. Tables A2.2.8 through A2.2.14 show precipitation intensity for durations of 5-, 10-, 15-, and 30-min, 1-, 2-, 3-, 6-, and 12-, and 24-hrs for return periods of 2-, 5-, 10-, 25-, 50-, 100-, and 1000-yrs, as a function of mean annual rainfall.






**1** 0 6 12 24 Miles  
Units are inches per year

— Mean annual precipitation for El Dorado County, CA  
 County boundary

Note:  
 Source: Report on El Dorado County design rainfall.  
 Prepared by Jim Goodridge, August 2008.



|          |                                  |
|----------|----------------------------------|
| Project: | El Dorado County drainage manual |
| Task:    | MAP mapping                      |
| Datum:   | NAD 83                           |
| Date:    | September 2008                   |

**FIG. A2.2.1 MEAN ANNUAL PRECIPITATION MAP FOR EL DORADO COUNTY**



*This page intentionally left blank.*

Table A2.2.1 Rainfall Depth Table with Return Period of 2 Years

**El Dorado County Design Rainfall  
Precipitation Depth Duration Frequency  
Return Period 2 Years**

| Mean Annual<br>Precipitation | 5<br>Min | 10<br>Min | 15<br>Min | 30<br>Min | 1<br>Hour | 2<br>Hour | 3<br>Hour | 6<br>Hour | 12<br>Hour | 1<br>Day | 2<br>Day | 3<br>Day | 4<br>Day | 5<br>Day | 6<br>Day | 8<br>Day | 10<br>Day | 15<br>Day | 20<br>Day | 30<br>Day | 60<br>Day | 365<br>Day |
|------------------------------|----------|-----------|-----------|-----------|-----------|-----------|-----------|-----------|------------|----------|----------|----------|----------|----------|----------|----------|-----------|-----------|-----------|-----------|-----------|------------|
| 8                            | 0.04     | 0.06      | 0.07      | 0.10      | 0.14      | 0.19      | 0.23      | 0.33      | 0.46       | 0.65     | 0.87     | 1.01     | 1.11     | 1.20     | 1.27     | 1.44     | 1.60      | 1.93      | 2.18      | 2.69      | 3.91      | 7.81       |
| 10                           | 0.05     | 0.07      | 0.09      | 0.12      | 0.17      | 0.24      | 0.29      | 0.41      | 0.58       | 0.81     | 1.09     | 1.26     | 1.39     | 1.50     | 1.59     | 1.80     | 2.00      | 2.41      | 2.72      | 3.36      | 4.89      | 9.76       |
| 12                           | 0.06     | 0.08      | 0.10      | 0.14      | 0.20      | 0.29      | 0.35      | 0.49      | 0.69       | 0.98     | 1.31     | 1.51     | 1.67     | 1.81     | 1.91     | 2.16     | 2.40      | 2.89      | 3.26      | 4.03      | 5.87      | 11.71      |
| 14                           | 0.07     | 0.10      | 0.12      | 0.17      | 0.24      | 0.33      | 0.41      | 0.57      | 0.81       | 1.14     | 1.53     | 1.77     | 1.94     | 2.11     | 2.23     | 2.52     | 2.80      | 3.38      | 3.81      | 4.70      | 6.85      | 13.66      |
| 16                           | 0.08     | 0.11      | 0.14      | 0.19      | 0.27      | 0.38      | 0.47      | 0.66      | 0.93       | 1.30     | 1.75     | 2.02     | 2.22     | 2.41     | 2.55     | 2.88     | 3.21      | 3.86      | 4.35      | 5.38      | 7.83      | 15.61      |
| 18                           | 0.09     | 0.13      | 0.15      | 0.22      | 0.31      | 0.43      | 0.52      | 0.74      | 1.04       | 1.47     | 1.97     | 2.27     | 2.50     | 2.71     | 2.86     | 3.24     | 3.61      | 4.34      | 4.90      | 6.05      | 8.81      | 17.57      |
| 20                           | 0.10     | 0.14      | 0.17      | 0.24      | 0.34      | 0.48      | 0.58      | 0.82      | 1.16       | 1.63     | 2.19     | 2.52     | 2.78     | 3.01     | 3.18     | 3.60     | 4.01      | 4.82      | 5.44      | 6.72      | 9.78      | 19.52      |
| 22                           | 0.11     | 0.15      | 0.19      | 0.26      | 0.37      | 0.53      | 0.64      | 0.90      | 1.27       | 1.79     | 2.40     | 2.78     | 3.06     | 3.31     | 3.50     | 3.96     | 4.41      | 5.30      | 5.98      | 7.39      | 10.76     | 21.47      |
| 24                           | 0.12     | 0.17      | 0.21      | 0.29      | 0.41      | 0.57      | 0.70      | 0.99      | 1.39       | 1.95     | 2.62     | 3.03     | 3.33     | 3.61     | 3.82     | 4.32     | 4.81      | 5.79      | 6.53      | 8.06      | 11.74     | 23.42      |
| 26                           | 0.13     | 0.18      | 0.22      | 0.31      | 0.44      | 0.62      | 0.76      | 1.07      | 1.50       | 2.12     | 2.84     | 3.28     | 3.61     | 3.91     | 4.14     | 4.68     | 5.21      | 6.27      | 7.07      | 8.73      | 12.72     | 25.37      |
| 28                           | 0.14     | 0.20      | 0.24      | 0.34      | 0.47      | 0.67      | 0.82      | 1.15      | 1.62       | 2.28     | 3.06     | 3.53     | 3.89     | 4.21     | 4.45     | 5.04     | 5.61      | 6.75      | 7.62      | 9.41      | 13.70     | 27.33      |
| 30                           | 0.15     | 0.21      | 0.26      | 0.36      | 0.51      | 0.72      | 0.87      | 1.23      | 1.74       | 2.44     | 3.28     | 3.78     | 4.17     | 4.51     | 4.77     | 5.40     | 6.01      | 7.23      | 8.16      | 10.08     | 14.68     | 29.28      |
| 35                           | 0.17     | 0.24      | 0.30      | 0.42      | 0.59      | 0.84      | 1.02      | 1.44      | 2.02       | 2.85     | 3.83     | 4.42     | 4.86     | 5.26     | 5.57     | 6.30     | 7.01      | 8.44      | 9.52      | 11.76     | 17.12     | 34.16      |
| 40                           | 0.20     | 0.28      | 0.34      | 0.48      | 0.68      | 0.95      | 1.17      | 1.64      | 2.31       | 3.26     | 4.37     | 5.05     | 5.56     | 6.02     | 6.36     | 7.20     | 8.01      | 9.64      | 10.88     | 13.44     | 19.57     | 39.04      |
| 45                           | 0.22     | 0.31      | 0.38      | 0.54      | 0.76      | 1.07      | 1.31      | 1.85      | 2.60       | 3.67     | 4.92     | 5.68     | 6.25     | 6.77     | 7.16     | 8.10     | 9.02      | 10.85     | 12.24     | 15.12     | 22.02     | 43.92      |
| 50                           | 0.25     | 0.35      | 0.43      | 0.60      | 0.85      | 1.19      | 1.46      | 2.05      | 2.89       | 4.07     | 5.47     | 6.31     | 6.94     | 7.52     | 7.95     | 9.00     | 10.02     | 12.06     | 13.60     | 16.80     | 24.46     | 48.80      |
| 55                           | 0.27     | 0.38      | 0.47      | 0.66      | 0.93      | 1.31      | 1.60      | 2.26      | 3.18       | 4.48     | 6.01     | 6.94     | 7.64     | 8.27     | 8.75     | 9.91     | 11.02     | 13.26     | 14.96     | 18.48     | 26.91     | 53.68      |
| 60                           | 0.30     | 0.42      | 0.51      | 0.72      | 1.02      | 1.43      | 1.75      | 2.46      | 3.47       | 4.89     | 6.56     | 7.57     | 8.33     | 9.03     | 9.54     | 10.81    | 12.02     | 14.47     | 16.32     | 20.16     | 29.35     | 58.55      |
| 65                           | 0.32     | 0.45      | 0.56      | 0.78      | 1.10      | 1.55      | 1.90      | 2.67      | 3.76       | 5.29     | 7.10     | 8.20     | 9.03     | 9.78     | 10.34    | 11.71    | 13.02     | 15.67     | 17.68     | 21.84     | 31.80     | 63.43      |
| 70                           | 0.35     | 0.49      | 0.60      | 0.84      | 1.19      | 1.67      | 2.04      | 2.87      | 4.05       | 5.70     | 7.65     | 8.83     | 9.72     | 10.53    | 11.13    | 12.61    | 14.02     | 16.88     | 19.04     | 23.52     | 34.25     | 68.31      |

Source: Design Rainfall Tables for El Dorado County prepared by Jim Goodridge, August 30, 2008

Table A2.2.2 Rainfall Depth Table with Return Period of 5 Years

El Dorado County Design Rainfall  
Precipitation Depth Duration Frequency  
Return Period 5 Years

| Mean Annual<br>Precipitation | 5<br>Min | 10<br>Min | 15<br>Min | 30<br>Min | 1<br>Hour | 2<br>Hour | 3<br>Hour | 6<br>Hour | 12<br>Hour | 1<br>Day | 2<br>Day | 3<br>Day | 4<br>Day | 5<br>Day | 6<br>Day | 8<br>Day | 10<br>Day | 15<br>Day | 20<br>Day | 30<br>Day | 60<br>Day | 365<br>Day |
|------------------------------|----------|-----------|-----------|-----------|-----------|-----------|-----------|-----------|------------|----------|----------|----------|----------|----------|----------|----------|-----------|-----------|-----------|-----------|-----------|------------|
| 8                            | 0.05     | 0.08      | 0.09      | 0.13      | 0.18      | 0.26      | 0.32      | 0.45      | 0.63       | 0.89     | 1.21     | 1.42     | 1.58     | 1.71     | 1.32     | 2.06     | 2.27      | 2.69      | 3.02      | 3.71      | 5.37      | 10.35      |
| 10                           | 0.07     | 0.10      | 0.12      | 0.16      | 0.23      | 0.32      | 0.40      | 0.56      | 0.79       | 1.11     | 1.51     | 1.78     | 1.97     | 2.14     | 2.27     | 2.57     | 2.83      | 3.36      | 3.78      | 4.64      | 6.72      | 12.93      |
| 12                           | 0.08     | 0.11      | 0.14      | 0.20      | 0.28      | 0.39      | 0.48      | 0.67      | 0.94       | 1.33     | 1.81     | 2.13     | 2.37     | 2.57     | 2.72     | 3.09     | 3.40      | 4.03      | 4.54      | 5.57      | 8.06      | 15.52      |
| 14                           | 0.09     | 0.13      | 0.16      | 0.23      | 0.32      | 0.45      | 0.55      | 0.78      | 1.10       | 1.55     | 2.12     | 2.49     | 2.76     | 3.00     | 3.18     | 3.60     | 3.97      | 4.70      | 5.29      | 6.50      | 9.40      | 18.11      |
| 16                           | 0.11     | 0.15      | 0.19      | 0.26      | 0.37      | 0.52      | 0.63      | 0.89      | 1.26       | 1.77     | 2.42     | 2.84     | 3.15     | 3.43     | 3.63     | 4.12     | 4.53      | 5.37      | 6.05      | 7.43      | 10.74     | 20.69      |
| 18                           | 0.12     | 0.17      | 0.21      | 0.29      | 0.41      | 0.58      | 0.71      | 1.00      | 1.42       | 1.99     | 2.72     | 3.20     | 3.55     | 3.86     | 4.09     | 4.63     | 5.10      | 6.04      | 6.81      | 8.35      | 12.09     | 23.28      |
| 20                           | 0.14     | 0.19      | 0.23      | 0.33      | 0.46      | 0.65      | 0.79      | 1.12      | 1.57       | 2.21     | 3.02     | 3.55     | 3.94     | 4.28     | 4.54     | 5.15     | 5.67      | 6.72      | 7.56      | 9.28      | 13.43     | 25.87      |
| 22                           | 0.15     | 0.21      | 0.26      | 0.36      | 0.51      | 0.71      | 0.87      | 1.23      | 1.73       | 2.44     | 3.32     | 3.91     | 4.34     | 4.71     | 4.99     | 5.66     | 6.23      | 7.39      | 8.32      | 10.21     | 14.77     | 28.45      |
| 24                           | 0.16     | 0.23      | 0.28      | 0.39      | 0.55      | 0.78      | 0.95      | 1.34      | 1.89       | 2.66     | 3.63     | 4.26     | 4.73     | 5.14     | 5.45     | 6.18     | 6.80      | 8.06      | 9.07      | 11.14     | 16.12     | 31.04      |
| 26                           | 0.18     | 0.25      | 0.30      | 0.43      | 0.60      | 0.84      | 1.03      | 1.45      | 2.04       | 2.88     | 3.93     | 4.62     | 5.13     | 5.57     | 5.90     | 6.69     | 7.37      | 8.73      | 9.83      | 12.07     | 17.46     | 33.63      |
| 28                           | 0.19     | 0.27      | 0.33      | 0.46      | 0.65      | 0.91      | 1.11      | 1.56      | 2.20       | 3.10     | 4.23     | 4.97     | 5.52     | 6.00     | 6.35     | 7.21     | 7.93      | 9.40      | 10.59     | 12.99     | 18.80     | 36.22      |
| 30                           | 0.20     | 0.29      | 0.35      | 0.49      | 0.69      | 0.97      | 1.19      | 1.67      | 2.36       | 3.32     | 4.53     | 5.33     | 5.91     | 6.43     | 6.81     | 7.72     | 8.50      | 10.07     | 11.34     | 13.92     | 20.15     | 38.80      |
| 35                           | 0.24     | 0.33      | 0.41      | 0.57      | 0.81      | 1.14      | 1.39      | 1.95      | 2.75       | 3.88     | 5.29     | 6.22     | 6.90     | 7.50     | 7.94     | 9.01     | 9.92      | 11.75     | 13.23     | 16.24     | 23.50     | 45.27      |
| 40                           | 0.27     | 0.38      | 0.46      | 0.65      | 0.92      | 1.30      | 1.59      | 2.23      | 3.15       | 4.43     | 6.04     | 7.11     | 7.89     | 8.57     | 9.08     | 10.29    | 11.33     | 13.43     | 15.12     | 18.56     | 26.86     | 51.74      |
| 45                           | 0.30     | 0.43      | 0.52      | 0.74      | 1.04      | 1.46      | 1.78      | 2.51      | 3.54       | 4.98     | 6.80     | 7.99     | 8.87     | 9.64     | 10.21    | 11.58    | 12.75     | 15.11     | 17.01     | 20.88     | 30.22     | 58.20      |
| 50                           | 0.34     | 0.48      | 0.58      | 0.82      | 1.15      | 1.62      | 1.98      | 2.79      | 3.93       | 5.54     | 7.56     | 8.88     | 9.86     | 10.71    | 11.35    | 12.87    | 14.17     | 16.79     | 18.91     | 23.21     | 33.58     | 64.67      |
| 55                           | 0.37     | 0.52      | 0.64      | 0.90      | 1.27      | 1.78      | 2.18      | 3.07      | 4.32       | 6.09     | 8.31     | 9.77     | 10.84    | 11.78    | 12.48    | 14.15    | 15.58     | 18.47     | 20.80     | 25.53     | 36.93     | 71.14      |
| 60                           | 0.41     | 0.57      | 0.70      | 0.98      | 1.38      | 1.95      | 2.38      | 3.35      | 4.72       | 6.64     | 9.07     | 10.66    | 11.83    | 12.85    | 13.62    | 15.44    | 17.00     | 20.15     | 22.69     | 27.85     | 40.29     | 77.60      |
| 65                           | 0.44     | 0.62      | 0.76      | 1.06      | 1.50      | 2.11      | 2.58      | 3.63      | 5.11       | 7.20     | 9.82     | 11.55    | 12.81    | 13.92    | 14.75    | 16.73    | 18.42     | 21.83     | 24.58     | 30.17     | 43.65     | 84.07      |
| 70                           | 0.47     | 0.67      | 0.81      | 1.15      | 1.61      | 2.27      | 2.77      | 3.91      | 5.50       | 7.75     | 10.58    | 12.43    | 13.80    | 15.00    | 15.89    | 18.01    | 19.83     | 23.50     | 26.47     | 32.49     | 47.01     | 90.54      |

Source: Design Rainfall Tables for El Dorado County prepared by Jim Goodridge, August 30, 2008

Table A2.2.3 Rainfall Depth Table with Return Period of 10 Years

El Dorado County Design Rainfall  
Precipitation Depth Duration Frequency  
Return Period 10 Years

| Mean Annual<br>Precipitation | 5<br>Min | 10<br>Min | 15<br>Min | 30<br>Min | 1<br>Hour | 2<br>Hour | 3<br>Hour | 6<br>Hour | 12<br>Hour | 1<br>Day | 2<br>Day | 3<br>Day | 4<br>Day | 5<br>Day | 6<br>Day | 8<br>Day | 10<br>Day | 15<br>Day | 20<br>Day | 30<br>Day | 60<br>Day | 365<br>Day |
|------------------------------|----------|-----------|-----------|-----------|-----------|-----------|-----------|-----------|------------|----------|----------|----------|----------|----------|----------|----------|-----------|-----------|-----------|-----------|-----------|------------|
| 8                            | 0.06     | 0.09      | 0.11      | 0.15      | 0.22      | 0.30      | 0.37      | 0.52      | 0.73       | 1.03     | 1.42     | 1.68     | 1.87     | 2.04     | 2.16     | 2.44     | 2.67      | 3.13      | 3.53      | 4.32      | 6.22      | 11.79      |
| 10                           | 0.08     | 0.11      | 0.14      | 0.19      | 0.27      | 0.38      | 0.46      | 0.65      | 0.92       | 1.29     | 1.78     | 2.10     | 2.34     | 2.54     | 2.70     | 3.05     | 3.34      | 3.92      | 4.42      | 5.40      | 7.77      | 14.74      |
| 12                           | 0.09     | 0.13      | 0.16      | 0.23      | 0.32      | 0.45      | 0.56      | 0.78      | 1.10       | 1.55     | 2.13     | 2.52     | 2.81     | 3.05     | 3.24     | 3.66     | 4.01      | 4.70      | 5.30      | 6.48      | 9.32      | 17.68      |
| 14                           | 0.11     | 0.16      | 0.19      | 0.27      | 0.38      | 0.53      | 0.65      | 0.91      | 1.28       | 1.81     | 2.49     | 2.94     | 3.27     | 3.56     | 3.78     | 4.28     | 4.68      | 5.48      | 6.18      | 7.56      | 10.88     | 20.63      |
| 16                           | 0.13     | 0.18      | 0.22      | 0.31      | 0.43      | 0.61      | 0.74      | 1.04      | 1.47       | 2.07     | 2.84     | 3.36     | 3.74     | 4.07     | 4.32     | 4.89     | 5.34      | 6.27      | 7.07      | 8.64      | 12.43     | 23.58      |
| 18                           | 0.14     | 0.20      | 0.24      | 0.34      | 0.48      | 0.68      | 0.83      | 1.17      | 1.65       | 2.33     | 3.20     | 3.78     | 4.21     | 4.58     | 4.86     | 5.50     | 6.01      | 7.05      | 7.95      | 9.72      | 13.98     | 26.52      |
| 20                           | 0.16     | 0.22      | 0.27      | 0.38      | 0.54      | 0.76      | 0.93      | 1.30      | 1.83       | 2.58     | 3.55     | 4.20     | 4.68     | 5.09     | 5.40     | 6.11     | 6.68      | 7.83      | 8.83      | 10.79     | 15.54     | 29.47      |
| 22                           | 0.17     | 0.24      | 0.30      | 0.42      | 0.59      | 0.83      | 1.02      | 1.43      | 2.02       | 2.84     | 3.91     | 4.62     | 5.15     | 5.60     | 5.94     | 6.72     | 7.35      | 8.62      | 9.72      | 11.87     | 17.09     | 32.42      |
| 24                           | 0.19     | 0.27      | 0.33      | 0.46      | 0.65      | 0.91      | 1.11      | 1.56      | 2.20       | 3.10     | 4.26     | 5.04     | 5.61     | 6.11     | 6.48     | 7.33     | 8.01      | 9.40      | 10.60     | 12.95     | 18.65     | 35.36      |
| 26                           | 0.20     | 0.29      | 0.35      | 0.50      | 0.70      | 0.98      | 1.20      | 1.69      | 2.39       | 3.36     | 4.62     | 5.46     | 6.08     | 6.62     | 7.02     | 7.94     | 8.68      | 10.18     | 11.48     | 14.03     | 20.20     | 38.31      |
| 28                           | 0.22     | 0.31      | 0.38      | 0.53      | 0.75      | 1.06      | 1.30      | 1.82      | 2.57       | 3.62     | 4.97     | 5.88     | 6.55     | 7.13     | 7.55     | 8.55     | 9.35      | 10.97     | 12.37     | 15.11     | 21.75     | 41.26      |
| 30                           | 0.24     | 0.33      | 0.41      | 0.57      | 0.81      | 1.14      | 1.39      | 1.95      | 2.75       | 3.88     | 5.33     | 6.30     | 7.02     | 7.63     | 8.09     | 9.16     | 10.02     | 11.75     | 13.25     | 16.19     | 23.31     | 44.21      |
| 35                           | 0.28     | 0.39      | 0.47      | 0.67      | 0.94      | 1.33      | 1.62      | 2.28      | 3.21       | 4.52     | 6.21     | 7.35     | 8.19     | 8.91     | 9.44     | 10.69    | 11.69     | 13.71     | 15.46     | 18.89     | 27.19     | 51.57      |
| 40                           | 0.32     | 0.44      | 0.54      | 0.76      | 1.08      | 1.51      | 1.85      | 2.61      | 3.67       | 5.17     | 7.10     | 8.40     | 9.36     | 10.18    | 10.79    | 12.21    | 13.36     | 15.67     | 17.67     | 21.59     | 31.08     | 58.94      |
| 45                           | 0.35     | 0.50      | 0.61      | 0.86      | 1.21      | 1.70      | 2.08      | 2.93      | 4.13       | 5.81     | 7.99     | 9.46     | 10.53    | 11.45    | 12.14    | 13.74    | 15.03     | 17.62     | 19.88     | 24.29     | 34.96     | 66.31      |
| 50                           | 0.39     | 0.55      | 0.68      | 0.95      | 1.34      | 1.89      | 2.31      | 3.26      | 4.59       | 6.46     | 8.88     | 10.51    | 11.69    | 12.72    | 13.49    | 15.27    | 16.70     | 19.58     | 22.08     | 26.99     | 38.84     | 73.68      |
| 55                           | 0.43     | 0.61      | 0.75      | 1.05      | 1.48      | 2.08      | 2.54      | 3.58      | 5.05       | 7.11     | 9.76     | 11.56    | 12.86    | 14.00    | 14.84    | 16.79    | 18.37     | 21.54     | 24.29     | 29.69     | 42.73     | 81.04      |
| 60                           | 0.47     | 0.67      | 0.81      | 1.15      | 1.61      | 2.27      | 2.78      | 3.91      | 5.50       | 7.75     | 10.65    | 12.61    | 14.03    | 15.27    | 16.19    | 18.32    | 20.04     | 23.50     | 26.50     | 32.38     | 46.61     | 88.41      |
| 65                           | 0.51     | 0.72      | 0.88      | 1.24      | 1.75      | 2.46      | 3.01      | 4.23      | 5.96       | 8.40     | 11.54    | 13.66    | 15.20    | 16.54    | 17.54    | 19.85    | 21.71     | 25.46     | 28.71     | 35.08     | 50.50     | 95.78      |
| 70                           | 0.55     | 0.78      | 0.95      | 1.34      | 1.88      | 2.65      | 3.24      | 4.56      | 6.42       | 9.04     | 12.43    | 14.71    | 16.37    | 17.81    | 18.89    | 21.38    | 23.38     | 27.42     | 30.92     | 37.78     | 54.38     | 103.15     |

Source: Design Rainfall Tables for El Dorado County prepared by Jim Goodridge, August 30, 2008

Table A2.2.4 Rainfall Depth Table with Return Period of 25 Years

**El Dorado County Design Rainfall  
Precipitation Depth Duration Frequency  
Return Period 25 Years**

| Mean Annual<br>Precipitation | 5<br>Min | 10<br>Min | 15<br>Min | 30<br>Min | 1<br>Hour | 2<br>Hour | 3<br>Hour | 6<br>Hour | 12<br>Hour | 1<br>Day | 2<br>Day | 3<br>Day | 4<br>Day | 5<br>Day | 6<br>Day | 8<br>Day | 10<br>Day | 15<br>Day | 20<br>Day | 30<br>Day | 60<br>Day | 365<br>Day |
|------------------------------|----------|-----------|-----------|-----------|-----------|-----------|-----------|-----------|------------|----------|----------|----------|----------|----------|----------|----------|-----------|-----------|-----------|-----------|-----------|------------|
| 8                            | 0.07     | 0.10      | 0.13      | 0.18      | 0.25      | 0.36      | 0.43      | 0.61      | 0.86       | 1.21     | 1.68     | 1.99     | 2.23     | 2.43     | 2.57     | 2.90     | 3.15      | 3.65      | 4.13      | 5.01      | 7.18      | 13.41      |
| 10                           | 0.09     | 0.13      | 0.16      | 0.22      | 0.32      | 0.44      | 0.54      | 0.76      | 1.08       | 1.52     | 2.09     | 2.49     | 2.78     | 3.03     | 3.22     | 3.63     | 3.94      | 4.56      | 5.16      | 6.27      | 8.97      | 16.76      |
| 12                           | 0.11     | 0.16      | 0.19      | 0.27      | 0.38      | 0.53      | 0.65      | 0.92      | 1.29       | 1.82     | 2.51     | 2.99     | 3.34     | 3.64     | 3.86     | 4.35     | 4.72      | 5.47      | 6.19      | 7.52      | 10.76     | 20.11      |
| 14                           | 0.13     | 0.18      | 0.22      | 0.31      | 0.44      | 0.62      | 0.76      | 1.07      | 1.51       | 2.12     | 2.93     | 3.49     | 3.90     | 4.24     | 4.50     | 5.08     | 5.51      | 6.38      | 7.22      | 8.78      | 12.56     | 23.46      |
| 16                           | 0.15     | 0.21      | 0.25      | 0.36      | 0.50      | 0.71      | 0.87      | 1.22      | 1.72       | 2.42     | 3.35     | 3.99     | 4.45     | 4.85     | 5.15     | 5.80     | 6.30      | 7.30      | 8.25      | 10.03     | 14.35     | 26.82      |
| 18                           | 0.17     | 0.23      | 0.29      | 0.40      | 0.57      | 0.80      | 0.98      | 1.38      | 1.94       | 2.73     | 3.77     | 4.49     | 5.01     | 5.46     | 5.79     | 6.53     | 7.09      | 8.21      | 9.29      | 11.28     | 16.15     | 30.17      |
| 20                           | 0.18     | 0.26      | 0.32      | 0.45      | 0.63      | 0.89      | 1.08      | 1.53      | 2.15       | 3.03     | 4.19     | 4.99     | 5.57     | 6.06     | 6.43     | 7.25     | 7.87      | 9.12      | 10.32     | 12.54     | 17.94     | 33.52      |
| 22                           | 0.20     | 0.29      | 0.35      | 0.49      | 0.69      | 0.98      | 1.19      | 1.68      | 2.37       | 3.33     | 4.61     | 5.49     | 6.12     | 6.67     | 7.07     | 7.98     | 8.66      | 10.03     | 11.35     | 13.79     | 19.73     | 36.87      |
| 24                           | 0.22     | 0.31      | 0.38      | 0.54      | 0.76      | 1.07      | 1.30      | 1.83      | 2.58       | 3.64     | 5.03     | 5.98     | 6.68     | 7.28     | 7.72     | 8.70     | 9.45      | 10.94     | 12.38     | 15.04     | 21.53     | 40.22      |
| 26                           | 0.24     | 0.34      | 0.41      | 0.58      | 0.82      | 1.15      | 1.41      | 1.99      | 2.80       | 3.94     | 5.44     | 6.48     | 7.24     | 7.88     | 8.36     | 9.43     | 10.24     | 11.86     | 13.41     | 16.30     | 23.32     | 43.58      |
| 28                           | 0.26     | 0.36      | 0.45      | 0.63      | 0.88      | 1.24      | 1.52      | 2.14      | 3.01       | 4.24     | 5.86     | 6.98     | 7.79     | 8.49     | 9.00     | 10.15    | 11.02     | 12.77     | 14.45     | 17.55     | 25.12     | 46.93      |
| 30                           | 0.28     | 0.39      | 0.48      | 0.67      | 0.95      | 1.33      | 1.63      | 2.29      | 3.23       | 4.55     | 6.28     | 7.48     | 8.35     | 9.09     | 9.65     | 10.88    | 11.81     | 13.68     | 15.48     | 18.80     | 26.91     | 50.28      |
| 35                           | 0.32     | 0.46      | 0.56      | 0.78      | 1.10      | 1.55      | 1.90      | 2.67      | 3.77       | 5.30     | 7.33     | 8.73     | 9.74     | 10.61    | 11.26    | 12.69    | 13.78     | 15.96     | 18.06     | 21.94     | 31.39     | 58.66      |
| 40                           | 0.37     | 0.52      | 0.64      | 0.90      | 1.26      | 1.78      | 2.17      | 3.06      | 4.30       | 6.06     | 8.38     | 9.97     | 11.13    | 12.13    | 12.86    | 14.50    | 15.75     | 18.24     | 20.64     | 25.07     | 35.88     | 67.04      |
| 45                           | 0.42     | 0.59      | 0.72      | 1.01      | 1.42      | 2.00      | 2.44      | 3.44      | 4.84       | 6.82     | 9.42     | 11.22    | 12.52    | 13.64    | 14.47    | 16.31    | 17.72     | 20.52     | 23.22     | 28.21     | 40.36     | 75.42      |
| 50                           | 0.46     | 0.65      | 0.79      | 1.12      | 1.58      | 2.22      | 2.71      | 3.82      | 5.38       | 7.58     | 10.47    | 12.47    | 13.92    | 15.16    | 16.08    | 18.13    | 19.69     | 22.80     | 25.80     | 31.34     | 44.85     | 83.80      |
| 55                           | 0.51     | 0.72      | 0.87      | 1.23      | 1.73      | 2.44      | 2.98      | 4.20      | 5.92       | 8.33     | 11.52    | 13.71    | 15.31    | 16.67    | 17.69    | 19.94    | 21.65     | 25.08     | 28.38     | 34.47     | 49.33     | 92.18      |
| 60                           | 0.55     | 0.78      | 0.95      | 1.34      | 1.89      | 2.66      | 3.25      | 4.58      | 6.46       | 9.09     | 12.56    | 14.96    | 16.70    | 18.19    | 19.30    | 21.75    | 23.62     | 27.36     | 30.96     | 37.61     | 53.82     | 100.56     |
| 65                           | 0.60     | 0.85      | 1.03      | 1.46      | 2.05      | 2.89      | 3.53      | 4.97      | 6.99       | 9.85     | 13.61    | 16.21    | 18.09    | 19.70    | 20.90    | 23.57    | 25.59     | 29.64     | 33.53     | 40.74     | 58.30     | 108.94     |
| 70                           | 0.65     | 0.91      | 1.11      | 1.57      | 2.21      | 3.11      | 3.80      | 5.35      | 7.53       | 10.61    | 14.66    | 17.46    | 19.48    | 21.22    | 22.51    | 25.38    | 27.56     | 31.92     | 36.11     | 43.88     | 62.79     | 117.32     |

Source: Design Rainfall Tables for El Dorado County prepared by Jim Goodridge, August 30, 2008

Table A2.2.5 Rainfall Depth Table with Return Period of 50 Years

**El Dorado County Design Rainfall  
Precipitation Depth Duration Frequency  
Return Period 50 Years**

| Mean Annual<br>Precipitation | 5<br>Min | 10<br>Min | 15<br>Min | 30<br>Min | 1<br>Hour | 2<br>Hour | 3<br>Hour | 6<br>Hour | 12<br>Hour | 1<br>Day | 2<br>Day | 3<br>Day | 4<br>Day | 5<br>Day | 6<br>Day | 8<br>Day | 10<br>Day | 15<br>Day | 20<br>Day | 30<br>Day | 60<br>Day | 365<br>Day |
|------------------------------|----------|-----------|-----------|-----------|-----------|-----------|-----------|-----------|------------|----------|----------|----------|----------|----------|----------|----------|-----------|-----------|-----------|-----------|-----------|------------|
| 8                            | 0.08     | 0.11      | 0.14      | 0.20      | 0.28      | 0.39      | 0.48      | 0.68      | 0.95       | 1.34     | 1.86     | 2.22     | 2.48     | 2.70     | 2.87     | 3.22     | 3.48      | 4.00      | 4.54      | 5.49      | 7.83      | 14.50      |
| 10                           | 0.10     | 0.14      | 0.18      | 0.25      | 0.35      | 0.49      | 0.60      | 0.84      | 1.19       | 1.67     | 2.32     | 2.77     | 3.10     | 3.38     | 3.58     | 4.03     | 4.36      | 5.00      | 5.67      | 6.87      | 9.79      | 18.13      |
| 12                           | 0.12     | 0.17      | 0.01      | 0.30      | 0.42      | 0.59      | 0.72      | 1.01      | 1.43       | 2.01     | 2.78     | 3.33     | 3.72     | 4.05     | 4.30     | 4.84     | 5.23      | 6.00      | 6.81      | 8.24      | 11.75     | 21.76      |
| 14                           | 0.14     | 0.20      | 0.25      | 0.35      | 0.49      | 0.69      | 0.84      | 1.18      | 1.66       | 2.34     | 3.25     | 3.88     | 4.34     | 4.73     | 5.02     | 5.64     | 6.10      | 7.00      | 7.94      | 9.61      | 13.71     | 25.38      |
| 16                           | 0.16     | 0.23      | 0.28      | 0.40      | 0.56      | 0.78      | 0.96      | 1.35      | 1.90       | 2.68     | 3.71     | 4.44     | 4.96     | 5.40     | 5.73     | 6.45     | 6.97      | 8.00      | 9.08      | 10.99     | 15.66     | 29.01      |
| 18                           | 0.18     | 0.26      | 0.32      | 0.45      | 0.63      | 0.88      | 1.08      | 1.52      | 2.14       | 3.01     | 4.18     | 4.99     | 5.58     | 6.08     | 6.45     | 7.25     | 7.84      | 9.00      | 10.21     | 12.36     | 17.62     | 32.63      |
| 20                           | 0.20     | 0.29      | 0.35      | 0.49      | 0.70      | 0.98      | 1.20      | 1.69      | 2.38       | 3.35     | 4.64     | 5.54     | 6.20     | 6.75     | 7.17     | 8.06     | 8.71      | 10.00     | 11.35     | 13.73     | 19.58     | 36.26      |
| 22                           | 0.22     | 0.32      | 0.39      | 0.54      | 0.77      | 1.08      | 1.32      | 1.86      | 2.61       | 3.68     | 5.11     | 6.10     | 6.82     | 7.43     | 7.88     | 8.87     | 9.58      | 11.01     | 12.48     | 15.11     | 21.54     | 39.88      |
| 24                           | 0.24     | 0.34      | 0.42      | 0.59      | 0.84      | 1.18      | 1.44      | 2.03      | 2.85       | 4.02     | 5.57     | 6.65     | 7.44     | 8.10     | 8.60     | 9.67     | 10.45     | 12.01     | 13.62     | 16.48     | 23.50     | 43.51      |
| 26                           | 0.27     | 0.37      | 0.46      | 0.64      | 0.91      | 1.28      | 1.56      | 2.19      | 3.09       | 4.35     | 6.03     | 7.21     | 8.06     | 8.78     | 9.32     | 10.48    | 11.33     | 13.01     | 14.75     | 17.86     | 25.46     | 47.14      |
| 28                           | 0.29     | 0.40      | 0.49      | 0.69      | 0.98      | 1.37      | 1.68      | 2.36      | 3.33       | 4.69     | 6.50     | 7.76     | 8.68     | 9.45     | 10.03    | 11.28    | 12.20     | 14.01     | 15.89     | 19.23     | 27.41     | 50.76      |
| 30                           | 0.31     | 0.43      | 0.53      | 0.74      | 1.04      | 1.47      | 1.80      | 2.53      | 3.57       | 5.02     | 6.96     | 8.32     | 9.30     | 10.13    | 10.75    | 12.09    | 13.07     | 15.01     | 17.02     | 20.60     | 29.37     | 54.39      |
| 35                           | 0.36     | 0.50      | 0.61      | 0.87      | 1.22      | 1.72      | 2.10      | 2.95      | 4.16       | 5.86     | 8.12     | 9.70     | 10.84    | 11.82    | 12.54    | 14.10    | 15.25     | 17.51     | 19.86     | 24.04     | 34.27     | 63.45      |
| 40                           | 0.41     | 0.57      | 0.70      | 0.99      | 1.39      | 1.96      | 2.40      | 3.38      | 4.75       | 6.70     | 9.28     | 11.09    | 12.39    | 13.51    | 14.33    | 16.12    | 17.42     | 20.01     | 22.70     | 27.47     | 39.16     | 72.52      |
| 45                           | 0.46     | 0.65      | 0.79      | 1.11      | 1.57      | 2.21      | 2.70      | 3.80      | 5.35       | 7.53     | 10.44    | 12.47    | 13.94    | 15.19    | 16.13    | 18.13    | 19.60     | 22.51     | 25.53     | 30.90     | 44.06     | 81.58      |
| 50                           | 0.51     | 0.72      | 0.88      | 1.24      | 1.74      | 2.45      | 3.00      | 4.22      | 5.94       | 8.37     | 11.60    | 13.86    | 15.49    | 16.88    | 17.92    | 20.15    | 21.78     | 25.01     | 28.37     | 34.34     | 48.95     | 90.65      |
| 55                           | 0.56     | 0.79      | 0.97      | 1.36      | 1.92      | 2.70      | 3.30      | 4.64      | 6.54       | 9.21     | 12.76    | 15.25    | 17.04    | 18.57    | 19.71    | 22.16    | 23.96     | 27.51     | 31.21     | 37.77     | 53.85     | 99.71      |
| 60                           | 0.61     | 0.86      | 1.05      | 1.48      | 2.09      | 2.94      | 3.60      | 5.06      | 7.13       | 10.04    | 13.92    | 16.63    | 18.59    | 20.26    | 21.50    | 24.18    | 26.14     | 30.01     | 34.05     | 41.20     | 58.74     | 108.78     |
| 65                           | 0.66     | 0.93      | 1.14      | 1.61      | 2.26      | 3.19      | 3.89      | 5.49      | 7.73       | 10.88    | 15.08    | 18.02    | 20.14    | 21.95    | 23.29    | 26.19    | 28.31     | 32.52     | 36.88     | 44.64     | 63.64     | 117.84     |
| 70                           | 0.71     | 1.01      | 1.23      | 1.73      | 2.44      | 3.43      | 4.19      | 5.91      | 8.32       | 11.72    | 16.24    | 19.41    | 21.69    | 23.64    | 25.08    | 28.21    | 30.79     | 35.02     | 39.72     | 48.07     | 68.53     | 126.91     |

Source: Design Rainfall Tables for El Dorado County prepared by Jim Goodridge, August 30, 2008



Table A2.2.6 Rainfall Depth Table with Return Period of 100 Years

**El Dorado County Design Rainfall  
Precipitation Depth Duration Frequency  
Return Period 100 Years**

| Mean Annual<br>Precipitation | 5<br>Min | 10<br>Min | 15<br>Min | 30<br>Min | 1<br>Hour | 2<br>Hour | 3<br>Hour | 6<br>Hour | 12<br>Hour | 1<br>Day | 2<br>Day | 3<br>Day | 4<br>Day | 5<br>Day | 6<br>Day | 8<br>Day | 10<br>Day | 15<br>Day | 20<br>Day | 30<br>Day | 60<br>Day | 365<br>Day |
|------------------------------|----------|-----------|-----------|-----------|-----------|-----------|-----------|-----------|------------|----------|----------|----------|----------|----------|----------|----------|-----------|-----------|-----------|-----------|-----------|------------|
| 8                            | 0.09     | 0.13      | 0.15      | 0.22      | 0.30      | 0.43      | 0.52      | 0.74      | 1.04       | 1.46     | 2.03     | 2.43     | 2.72     | 2.97     | 3.15     | 3.53     | 3.80      | 4.34      | 4.93      | 5.95      | 8.45      | 15.52      |
| 10                           | 0.11     | 0.16      | 0.19      | 0.27      | 0.38      | 0.54      | 0.65      | 0.92      | 1.30       | 1.83     | 2.54     | 3.04     | 3.40     | 3.71     | 3.94     | 4.42     | 4.75      | 5.42      | 6.16      | 7.43      | 10.56     | 19.40      |
| 12                           | 0.13     | 0.19      | 0.23      | 0.32      | 0.46      | 0.64      | 0.78      | 1.11      | 1.56       | 2.19     | 3.05     | 3.65     | 4.08     | 4.45     | 4.73     | 5.30     | 5.71      | 6.50      | 7.40      | 8.92      | 12.67     | 23.28      |
| 14                           | 0.16     | 0.22      | 0.27      | 0.38      | 0.53      | 0.75      | 0.92      | 1.29      | 1.82       | 2.56     | 3.55     | 4.26     | 4.76     | 5.19     | 5.51     | 6.18     | 6.66      | 7.59      | 8.63      | 10.41     | 14.78     | 27.16      |
| 16                           | 0.18     | 0.25      | 0.31      | 0.43      | 0.61      | 0.86      | 1.05      | 1.47      | 2.08       | 2.92     | 4.06     | 4.87     | 5.44     | 5.94     | 6.30     | 7.07     | 7.61      | 8.67      | 9.86      | 11.89     | 16.89     | 31.04      |
| 18                           | 0.20     | 0.28      | 0.34      | 0.49      | 0.68      | 0.96      | 1.18      | 1.66      | 2.33       | 3.29     | 4.57     | 5.47     | 6.12     | 6.68     | 7.09     | 7.95     | 8.56      | 9.76      | 11.09     | 13.38     | 19.00     | 34.92      |
| 20                           | 0.22     | 0.31      | 0.38      | 0.54      | 0.76      | 1.07      | 1.31      | 1.84      | 2.59       | 3.65     | 5.08     | 6.08     | 6.80     | 7.42     | 7.88     | 8.83     | 9.51      | 10.84     | 12.33     | 14.86     | 21.12     | 38.80      |
| 22                           | 0.24     | 0.34      | 0.42      | 0.59      | 0.84      | 1.18      | 1.44      | 2.03      | 2.85       | 4.02     | 5.59     | 6.69     | 7.48     | 8.16     | 8.66     | 9.72     | 10.46     | 11.92     | 13.56     | 16.35     | 23.23     | 42.69      |
| 24                           | 0.27     | 0.38      | 0.46      | 0.65      | 0.91      | 1.28      | 1.57      | 2.21      | 3.11       | 4.38     | 6.09     | 7.30     | 8.17     | 8.90     | 9.45     | 10.60    | 11.41     | 13.01     | 14.79     | 17.84     | 25.34     | 46.57      |
| 26                           | 0.29     | 0.41      | 0.50      | 0.70      | 0.99      | 1.39      | 1.70      | 2.39      | 3.37       | 4.75     | 6.60     | 7.91     | 8.85     | 9.64     | 10.24    | 11.48    | 12.36     | 14.09     | 16.02     | 19.32     | 27.45     | 50.45      |
| 28                           | 0.31     | 0.44      | 0.54      | 0.76      | 1.06      | 1.50      | 1.83      | 2.58      | 3.63       | 5.11     | 7.11     | 8.51     | 9.53     | 10.39    | 11.03    | 12.37    | 13.31     | 15.18     | 17.26     | 20.81     | 29.56     | 54.33      |
| 30                           | 0.33     | 0.47      | 0.57      | 0.81      | 1.14      | 1.61      | 1.96      | 2.76      | 3.89       | 5.48     | 7.62     | 9.12     | 10.21    | 11.13    | 11.81    | 13.25    | 14.26     | 16.26     | 18.49     | 22.30     | 31.67     | 58.21      |
| 35                           | 0.39     | 0.55      | 0.67      | 0.94      | 1.33      | 1.87      | 2.29      | 3.22      | 4.54       | 6.39     | 8.89     | 10.64    | 11.91    | 12.98    | 13.78    | 15.46    | 16.64     | 18.97     | 21.57     | 26.01     | 36.95     | 67.91      |
| 40                           | 0.45     | 0.63      | 0.77      | 1.08      | 1.52      | 2.14      | 2.62      | 3.68      | 5.19       | 7.31     | 10.15    | 12.16    | 13.61    | 14.84    | 15.75    | 17.67    | 19.02     | 21.68     | 24.65     | 29.73     | 42.23     | 77.61      |
| 45                           | 0.50     | 0.71      | 0.86      | 1.21      | 1.71      | 2.41      | 2.94      | 4.14      | 5.84       | 8.22     | 11.42    | 13.68    | 15.31    | 16.69    | 17.72    | 19.87    | 21.40     | 24.39     | 27.73     | 33.45     | 47.51     | 87.31      |
| 50                           | 0.56     | 0.78      | 0.96      | 1.35      | 1.90      | 2.68      | 3.27      | 4.60      | 6.48       | 9.13     | 12.69    | 15.20    | 17.01    | 18.55    | 19.69    | 22.08    | 23.77     | 27.10     | 30.81     | 37.16     | 52.79     | 97.01      |
| 55                           | 0.61     | 0.86      | 1.05      | 1.48      | 2.09      | 2.94      | 3.60      | 5.06      | 7.13       | 10.05    | 13.96    | 16.72    | 18.71    | 20.40    | 21.66    | 24.29    | 26.15     | 29.81     | 33.89     | 40.88     | 58.07     | 106.71     |
| 60                           | 0.67     | 0.94      | 1.15      | 1.62      | 2.28      | 3.21      | 3.92      | 5.53      | 7.78       | 10.96    | 15.23    | 18.24    | 20.41    | 22.26    | 23.63    | 26.50    | 28.53     | 32.52     | 36.98     | 44.59     | 63.35     | 116.41     |
| 65                           | 0.72     | 1.02      | 1.25      | 1.75      | 2.47      | 3.48      | 4.25      | 5.99      | 8.43       | 11.87    | 16.50    | 19.76    | 22.11    | 24.11    | 25.59    | 28.71    | 30.90     | 35.23     | 40.06     | 48.31     | 68.62     | 126.12     |
| 70                           | 0.78     | 1.10      | 1.34      | 1.89      | 2.66      | 3.75      | 4.58      | 6.45      | 9.08       | 12.79    | 17.77    | 21.28    | 23.82    | 25.97    | 27.56    | 30.92    | 33.28     | 37.94     | 43.14     | 52.03     | 73.90     | 135.82     |

Source: Design Rainfall Tables for El Dorado County prepared by Jim Goodridge, August 30, 2008

Table A2.2.7 Rainfall Depth Table with Return Period of 1000 Years

**El Dorado County Design Rainfall  
Precipitation Depth Duration Frequency  
Return Period 1000 Years**

| Mean Annual<br>Precipitation | 5<br>Min | 10<br>Min | 15<br>Min | 30<br>Min | 1<br>Hour | 2<br>Hour | 3<br>Hour | 6<br>Hour | 12<br>Hour | 1<br>Day | 2<br>Day | 3<br>Day | 4<br>Day | 5<br>Day | 6<br>Day | 8<br>Day | 10<br>Day | 15<br>Day | 20<br>Day | 30<br>Day | 60<br>Day | 365<br>Day |
|------------------------------|----------|-----------|-----------|-----------|-----------|-----------|-----------|-----------|------------|----------|----------|----------|----------|----------|----------|----------|-----------|-----------|-----------|-----------|-----------|------------|
| 8                            | 0.11     | 0.16      | 0.19      | 0.27      | 0.38      | 0.54      | 0.66      | 0.93      | 1.31       | 1.84     | 2.58     | 3.11     | 3.48     | 3.80     | 4.04     | 4.50     | 4.79      | 5.35      | 6.13      | 7.32      | 10.29     | 18.55      |
| 10                           | 0.14     | 0.20      | 0.24      | 0.34      | 0.48      | 0.68      | 0.83      | 1.16      | 1.64       | 2.31     | 3.22     | 3.88     | 4.35     | 4.75     | 5.05     | 5.62     | 5.99      | 6.69      | 7.66      | 9.15      | 12.86     | 23.18      |
| 12                           | 0.17     | 0.24      | 0.29      | 0.41      | 0.58      | 0.81      | 0.99      | 1.39      | 1.96       | 2.77     | 3.87     | 4.66     | 5.23     | 5.70     | 6.06     | 6.75     | 7.18      | 8.02      | 9.19      | 10.98     | 15.43     | 27.82      |
| 14                           | 0.20     | 0.28      | 0.34      | 0.48      | 0.67      | 0.95      | 1.16      | 1.63      | 2.29       | 3.23     | 4.51     | 5.44     | 6.10     | 6.65     | 7.07     | 7.87     | 8.38      | 9.36      | 10.72     | 12.80     | 18.00     | 32.45      |
| 16                           | 0.22     | 0.32      | 0.39      | 0.54      | 0.77      | 1.08      | 1.32      | 1.86      | 2.62       | 3.69     | 5.16     | 6.21     | 6.97     | 7.60     | 8.08     | 9.00     | 9.58      | 10.70     | 12.25     | 14.63     | 20.57     | 37.09      |
| 18                           | 0.25     | 0.36      | 0.44      | 0.61      | 0.86      | 1.22      | 1.49      | 2.09      | 2.95       | 4.15     | 5.80     | 6.99     | 7.84     | 8.56     | 9.09     | 10.12    | 10.77     | 12.03     | 13.78     | 16.46     | 23.15     | 41.73      |
| 20                           | 0.28     | 0.40      | 0.48      | 0.68      | 0.96      | 1.35      | 1.65      | 2.32      | 3.27       | 4.61     | 6.45     | 7.77     | 8.71     | 9.51     | 10.10    | 11.24    | 11.97     | 13.37     | 15.31     | 18.29     | 25.72     | 46.36      |
| 22                           | 0.31     | 0.44      | 0.53      | 0.75      | 1.06      | 1.49      | 1.82      | 2.56      | 3.60       | 5.07     | 7.09     | 8.54     | 9.58     | 10.46    | 11.11    | 12.37    | 13.17     | 14.71     | 16.84     | 20.12     | 28.29     | 51.00      |
| 24                           | 0.34     | 0.48      | 0.58      | 0.82      | 1.15      | 1.62      | 1.98      | 2.79      | 3.93       | 5.53     | 7.73     | 9.32     | 10.45    | 11.41    | 12.12    | 13.49    | 14.37     | 16.05     | 18.38     | 21.95     | 30.86     | 55.64      |
| 26                           | 0.37     | 0.51      | 0.63      | 0.89      | 1.25      | 1.76      | 2.15      | 3.02      | 4.26       | 5.99     | 8.38     | 10.09    | 11.32    | 12.36    | 13.12    | 14.62    | 15.56     | 17.38     | 19.91     | 23.78     | 33.43     | 60.27      |
| 28                           | 0.39     | 0.55      | 0.68      | 0.95      | 1.34      | 1.89      | 2.31      | 3.25      | 4.58       | 6.45     | 9.02     | 10.87    | 12.19    | 13.31    | 14.13    | 15.74    | 16.76     | 18.72     | 21.44     | 25.61     | 36.01     | 64.91      |
| 30                           | 0.42     | 0.59      | 0.73      | 1.02      | 1.44      | 2.03      | 2.48      | 3.49      | 4.91       | 6.92     | 9.67     | 11.65    | 13.06    | 14.26    | 15.14    | 16.87    | 17.96     | 20.06     | 22.97     | 27.44     | 38.58     | 69.54      |
| 35                           | 0.49     | 0.69      | 0.85      | 1.19      | 1.68      | 2.36      | 2.89      | 4.07      | 5.73       | 8.07     | 11.28    | 13.59    | 15.24    | 16.64    | 17.67    | 19.68    | 20.95     | 23.40     | 26.80     | 32.01     | 45.01     | 81.13      |
| 40                           | 0.56     | 0.79      | 0.97      | 1.36      | 1.92      | 2.70      | 3.30      | 4.65      | 6.55       | 9.22     | 12.89    | 15.53    | 17.42    | 19.01    | 20.19    | 22.49    | 23.94     | 26.74     | 30.63     | 36.59     | 51.44     | 92.73      |
| 45                           | 0.63     | 0.89      | 1.09      | 1.53      | 2.16      | 3.04      | 3.71      | 5.23      | 7.37       | 10.37    | 14.50    | 17.47    | 19.60    | 21.39    | 22.72    | 25.30    | 26.94     | 30.09     | 34.46     | 41.16     | 57.87     | 104.32     |
| 50                           | 0.70     | 0.99      | 1.21      | 1.70      | 2.40      | 3.38      | 4.13      | 5.81      | 8.18       | 11.53    | 16.11    | 19.41    | 21.77    | 23.76    | 25.24    | 28.11    | 29.93     | 33.43     | 38.28     | 45.73     | 64.30     | 115.91     |
| 55                           | 0.77     | 1.09      | 1.33      | 1.87      | 2.64      | 3.72      | 4.54      | 6.39      | 9.00       | 12.68    | 17.72    | 21.35    | 23.95    | 26.14    | 27.76    | 30.92    | 32.92     | 36.77     | 42.11     | 50.31     | 70.73     | 127.50     |
| 60                           | 0.84     | 1.19      | 1.45      | 2.04      | 2.88      | 4.05      | 4.95      | 6.97      | 9.82       | 13.83    | 19.34    | 23.30    | 26.13    | 28.52    | 30.29    | 33.73    | 35.91     | 40.12     | 45.94     | 54.88     | 77.16     | 139.09     |
| 65                           | 0.91     | 1.29      | 1.57      | 2.21      | 3.12      | 4.39      | 5.36      | 7.55      | 10.64      | 14.98    | 20.95    | 25.24    | 28.31    | 30.89    | 32.81    | 36.54    | 38.91     | 43.46     | 49.77     | 59.45     | 83.59     | 150.68     |
| 70                           | 0.98     | 1.39      | 1.69      | 2.38      | 3.36      | 4.73      | 5.78      | 8.14      | 11.46      | 16.14    | 22.56    | 27.18    | 30.48    | 33.27    | 35.34    | 39.35    | 41.90     | 46.80     | 53.60     | 64.02     | 90.02     | 162.27     |

Source: Design Rainfall Tables for El Dorado County prepared by Jim Goodridge, August 30, 2008

**Table A2.2.8 Rainfall Intensity with Return Period of 2 Years**

**El Dorado County Design Rainfall  
Precipitation Intensity (inches per hour) Duration Frequency  
Return Period 2 Years**

| Mean Annual<br>Precipitation | 5 Min | 10 Min | 15 Min | 30 Min | 1 Hr | 2 Hr | 3 Hr | 6 Hr | 12 Hr | 1 Day |
|------------------------------|-------|--------|--------|--------|------|------|------|------|-------|-------|
| 8                            | 0.48  | 0.34   | 0.27   | 0.19   | 0.14 | 0.10 | 0.08 | 0.05 | 0.04  | 0.03  |
| 10                           | 0.6   | 0.42   | 0.34   | 0.24   | 0.17 | 0.12 | 0.10 | 0.07 | 0.05  | 0.03  |
| 12                           | 0.72  | 0.5    | 0.41   | 0.29   | 0.20 | 0.14 | 0.12 | 0.08 | 0.06  | 0.04  |
| 14                           | 0.83  | 0.59   | 0.48   | 0.34   | 0.24 | 0.17 | 0.14 | 0.10 | 0.07  | 0.05  |
| 16                           | 0.95  | 0.67   | 0.55   | 0.39   | 0.27 | 0.19 | 0.16 | 0.11 | 0.08  | 0.05  |
| 18                           | 1.07  | 0.76   | 0.62   | 0.43   | 0.31 | 0.21 | 0.17 | 0.12 | 0.09  | 0.06  |
| 20                           | 1.19  | 0.84   | 0.68   | 0.48   | 0.34 | 0.24 | 0.19 | 0.14 | 0.10  | 0.07  |
| 22                           | 1.31  | 0.92   | 0.75   | 0.53   | 0.37 | 0.26 | 0.21 | 0.15 | 0.11  | 0.07  |
| 24                           | 1.43  | 1.01   | 0.82   | 0.58   | 0.41 | 0.29 | 0.23 | 0.16 | 0.12  | 0.08  |
| 26                           | 1.55  | 1.09   | 0.89   | 0.63   | 0.44 | 0.31 | 0.25 | 0.18 | 0.13  | 0.09  |
| 28                           | 1.67  | 1.17   | 0.96   | 0.67   | 0.47 | 0.33 | 0.27 | 0.19 | 0.13  | 0.10  |
| 30                           | 1.79  | 1.26   | 1.03   | 0.72   | 0.51 | 0.36 | 0.29 | 0.21 | 0.14  | 0.10  |
| 35                           | 2.09  | 1.47   | 1.20   | 0.84   | 0.59 | 0.42 | 0.34 | 0.24 | 0.17  | 0.12  |
| 40                           | 2.38  | 1.68   | 1.37   | 0.96   | 0.68 | 0.48 | 0.39 | 0.27 | 0.19  | 0.14  |
| 45                           | 2.68  | 1.89   | 1.54   | 1.08   | 0.76 | 0.54 | 0.44 | 0.31 | 0.22  | 0.15  |
| 50                           | 2.98  | 2.10   | 1.71   | 1.20   | 0.85 | 0.60 | 0.49 | 0.34 | 0.24  | 0.17  |
| 55                           | 3.28  | 2.31   | 1.88   | 1.32   | 0.93 | 0.66 | 0.53 | 0.38 | 0.27  | 0.19  |
| 60                           | 3.58  | 2.52   | 2.05   | 1.44   | 1.02 | 0.72 | 0.58 | 0.41 | 0.29  | 0.20  |
| 65                           | 3.87  | 2.73   | 2.22   | 1.56   | 1.10 | 0.78 | 0.63 | 0.44 | 0.31  | 0.22  |
| 70                           | 4.17  | 2.94   | 2.39   | 1.68   | 1.19 | 0.84 | 0.68 | 0.48 | 0.34  | 0.24  |

**Source: Design Rainfall Tables for El Dorado County prepared by Jim Goodridge, August 30, 2008**

**Table A2.2.9 Rainfall Intensity with Return Period of 5 Years**

**El Dorado County Design Rainfall  
Precipitation Intensity (inches per hour) Duration Frequency  
Return Period 5 Years**

| Mean Annual<br>Precipitation | 5 Min | 10 Min | 15 Min | 30 Min | 1 Hr | 2 Hr | 3 Hr | 6 Hr | 12 Hr | 1 Day |
|------------------------------|-------|--------|--------|--------|------|------|------|------|-------|-------|
| 8                            | 0.65  | 0.46   | 0.37   | 0.26   | 0.18 | 0.13 | 0.11 | 0.07 | 0.05  | 0.04  |
| 10                           | 0.81  | 0.57   | 0.46   | 0.33   | 0.23 | 0.16 | 0.13 | 0.09 | 0.07  | 0.05  |
| 12                           | 0.97  | 0.68   | 0.56   | 0.39   | 0.28 | 0.19 | 0.16 | 0.11 | 0.08  | 0.06  |
| 14                           | 1.13  | 0.80   | 0.65   | 0.46   | 0.32 | 0.23 | 0.18 | 0.13 | 0.09  | 0.06  |
| 16                           | 1.30  | 0.91   | 0.74   | 0.52   | 0.37 | 0.26 | 0.21 | 0.15 | 0.10  | 0.07  |
| 18                           | 1.46  | 1.03   | 0.84   | 0.59   | 0.41 | 0.29 | 0.24 | 0.17 | 0.12  | 0.08  |
| 20                           | 1.62  | 1.14   | 0.93   | 0.65   | 0.46 | 0.32 | 0.26 | 0.19 | 0.13  | 0.09  |
| 22                           | 1.78  | 1.25   | 1.02   | 0.72   | 0.51 | 0.36 | 0.29 | 0.20 | 0.14  | 0.10  |
| 24                           | 1.94  | 1.37   | 1.12   | 0.79   | 0.55 | 0.39 | 0.32 | 0.22 | 0.16  | 0.11  |
| 26                           | 2.11  | 1.48   | 1.21   | 0.85   | 0.60 | 0.42 | 0.34 | 0.24 | 0.17  | 0.12  |
| 28                           | 2.27  | 1.60   | 1.3    | 0.92   | 0.65 | 0.45 | 0.37 | 0.26 | 0.18  | 0.13  |
| 30                           | 2.43  | 1.71   | 1.39   | 0.98   | 0.69 | 0.49 | 0.40 | 0.28 | 0.20  | 0.14  |
| 35                           | 2.84  | 2.00   | 1.63   | 1.15   | 0.81 | 0.57 | 0.46 | 0.33 | 0.23  | 0.16  |
| 40                           | 3.24  | 2.28   | 1.86   | 1.31   | 0.92 | 0.65 | 0.53 | 0.37 | 0.26  | 0.18  |
| 45                           | 3.65  | 2.57   | 2.09   | 1.47   | 1.04 | 0.73 | 0.59 | 0.42 | 0.29  | 0.21  |
| 50                           | 4.05  | 2.85   | 2.32   | 1.64   | 1.15 | 0.81 | 0.66 | 0.47 | 0.33  | 0.23  |
| 55                           | 4.46  | 3.14   | 2.56   | 1.80   | 1.27 | 0.89 | 0.73 | 0.51 | 0.36  | 0.25  |
| 60                           | 4.86  | 3.42   | 2.79   | 1.96   | 1.38 | 0.97 | 0.79 | 0.56 | 0.39  | 0.28  |
| 65                           | 5.27  | 3.71   | 3.02   | 2.13   | 1.5  | 1.05 | 0.86 | 0.60 | 0.43  | 0.30  |
| 70                           | 5.67  | 3.99   | 3.25   | 2.29   | 1.61 | 1.14 | 0.92 | 0.65 | 0.46  | 0.32  |

**Source: Design Rainfall Tables for El Dorado County prepared by Jim Goodridge, August 30, 2008**

**Table A2.2.10 Rainfall Intensity with Return Period of 10 Years**

**El Dorado County Design Rainfall  
Precipitation Intensity (inches per hour) Duration Frequency  
Return Period 10 Years**

| Mean Annual<br>Precipitation | 5 Min | 10 Min | 15 Min | 30 Min | 1 Hr | 2 Hr | 3 Hr | 6 Hr | 12 Hr | 1 Day |
|------------------------------|-------|--------|--------|--------|------|------|------|------|-------|-------|
| 8                            | 0.76  | 0.53   | 0.43   | 0.31   | 0.22 | 0.15 | 0.12 | 0.09 | 0.06  | 0.04  |
| 10                           | 0.95  | 0.67   | 0.54   | 0.38   | 0.27 | 0.19 | 0.15 | 0.11 | 0.08  | 0.05  |
| 12                           | 1.133 | 0.80   | 0.65   | 0.46   | 0.32 | 0.23 | 0.19 | 0.13 | 0.09  | 0.06  |
| 14                           | 1.32  | 0.93   | 0.76   | 0.53   | 0.38 | 0.27 | 0.22 | 0.15 | 0.11  | 0.08  |
| 16                           | 1.51  | 1.06   | 0.87   | 0.61   | 0.43 | 0.30 | 0.25 | 0.17 | 0.12  | 0.09  |
| 18                           | 1.70  | 1.20   | 0.98   | 0.69   | 0.48 | 0.34 | 0.28 | 0.20 | 0.14  | 0.10  |
| 20                           | 1.89  | 1.33   | 1.08   | 0.76   | 0.54 | 0.38 | 0.31 | 0.22 | 0.15  | 0.11  |
| 22                           | 2.08  | 1.46   | 1.19   | 0.84   | 0.59 | 0.42 | 0.34 | 0.24 | 0.17  | 0.12  |
| 24                           | 2.27  | 1.60   | 1.30   | 0.92   | 0.65 | 0.45 | 0.37 | 0.26 | 0.18  | 0.13  |
| 26                           | 2.46  | 1.73   | 1.41   | 0.99   | 0.70 | 0.49 | 0.40 | 0.28 | 0.20  | 0.14  |
| 28                           | 2.65  | 1.86   | 1.52   | 1.07   | 0.75 | 0.53 | 0.43 | 0.30 | 0.21  | 0.15  |
| 30                           | 2.84  | 2.0    | 1.63   | 1.15   | 0.81 | 0.57 | 0.46 | 0.33 | 0.23  | 0.16  |
| 35                           | 3.31  | 2.33   | 1.90   | 1.34   | 0.94 | 0.66 | 0.54 | 0.38 | 0.27  | 0.19  |
| 40                           | 3.78  | 2.66   | 2.17   | 1.53   | 1.08 | 0.76 | 0.62 | 0.43 | 0.31  | 0.22  |
| 45                           | 4.25  | 3.00   | 2.44   | 1.72   | 1.21 | 0.85 | 0.69 | 0.49 | 0.34  | 0.24  |
| 50                           | 4.73  | 3.33   | 2.71   | 1.91   | 1.34 | 0.95 | 0.77 | 0.54 | 0.38  | 0.27  |
| 55                           | 5.2   | 3.66   | 2.98   | 2.10   | 1.48 | 1.04 | 0.85 | 0.60 | 0.42  | 0.30  |
| 60                           | 5.67  | 3.99   | 3.25   | 2.29   | 1.61 | 1.14 | 0.93 | 0.65 | 0.46  | 0.32  |
| 65                           | 6.14  | 4.33   | 3.52   | 2.48   | 1.75 | 1.23 | 1.00 | 0.71 | 0.50  | 0.35  |
| 70                           | 6.62  | 4.66   | 3.80   | 2.67   | 1.88 | 1.33 | 1.08 | 0.76 | 0.54  | 0.38  |

**Source: Design Rainfall Tables for El Dorado County prepared by Jim Goodridge, August 30, 2008**

**Table A2.2.11 Rainfall Intensity with Return Period of 25 Years**

**El Dorado County Design Rainfall  
Precipitation Intensity (inches per hour) Duration Frequency  
Return Period 25 Years**

| Mean Annual<br>Precipitation | 5 Min | 10 Min | 15 Min | 30 Min | 1 Hr | 2 Hr | 3 Hr | 6 Hr | 12 Hr | 1 Day |
|------------------------------|-------|--------|--------|--------|------|------|------|------|-------|-------|
| 8                            | 0.89  | 0.62   | 0.51   | 0.36   | 0.25 | 0.18 | 0.14 | 0.10 | 0.07  | 0.05  |
| 10                           | 1.11  | 0.78   | 0.64   | 0.45   | 0.32 | 0.22 | 0.18 | 0.13 | 0.09  | 0.06  |
| 12                           | 1.33  | 0.94   | 0.76   | 0.54   | 0.38 | 0.27 | 0.22 | 0.15 | 0.11  | 0.08  |
| 14                           | 1.55  | 1.09   | 0.89   | 0.64   | 0.44 | 0.31 | 0.25 | 0.18 | 0.13  | 0.09  |
| 16                           | 1.77  | 1.25   | 1.02   | 0.72   | 0.50 | 0.36 | 0.29 | 0.20 | 0.14  | 0.10  |
| 18                           | 2.00  | 1.41   | 1.14   | 0.81   | 0.57 | 0.40 | 0.33 | 0.23 | 0.16  | 0.11  |
| 20                           | 2.22  | 1.56   | 1.27   | 0.90   | 0.63 | 0.44 | 0.36 | 0.25 | 0.18  | 0.13  |
| 22                           | 2.44  | 1.72   | 1.40   | 0.98   | 0.69 | 0.49 | 0.40 | 0.28 | 0.20  | 0.14  |
| 24                           | 2.66  | 1.87   | 1.53   | 1.07   | 0.76 | 0.53 | 0.43 | 0.31 | 0.22  | 0.15  |
| 26                           | 2.88  | 2.03   | 1.65   | 1.16   | 0.82 | 0.58 | 0.47 | 0.33 | 0.23  | 0.16  |
| 28                           | 3.10  | 2.19   | 1.78   | 1.25   | 0.88 | 0.62 | 0.51 | 0.36 | 0.25  | 0.18  |
| 30                           | 3.33  | 2.34   | 1.91   | 1.34   | 0.95 | 0.67 | 0.54 | 0.38 | 0.27  | 0.19  |
| 35                           | 3.88  | 2.73   | 2.23   | 1.57   | 1.10 | 0.78 | 0.63 | 0.45 | 0.31  | 0.22  |
| 40                           | 4.43  | 3.12   | 2.54   | 1.79   | 1.26 | 0.89 | 0.72 | 0.51 | 0.36  | 0.25  |
| 45                           | 4.99  | 3.51   | 2.86   | 2.01   | 1.42 | 1.00 | 0.81 | 0.57 | 0.40  | 0.28  |
| 50                           | 5.54  | 3.90   | 3.18   | 2.24   | 1.58 | 1.11 | 0.90 | 0.64 | 0.45  | 0.32  |
| 55                           | 6.10  | 4.29   | 3.50   | 2.46   | 1.73 | 1.22 | 0.99 | 0.70 | 0.49  | 0.35  |
| 60                           | 6.65  | 4.68   | 3.81   | 2.69   | 1.89 | 1.33 | 1.08 | 0.76 | 0.54  | 0.38  |
| 65                           | 7.21  | 5.07   | 4.13   | 2.91   | 2.05 | 1.44 | 1.18 | 0.83 | 0.58  | 0.41  |
| 70                           | 7.76  | 5.46   | 4.45   | 3.13   | 2.21 | 1.55 | 1.27 | 0.89 | 0.63  | 0.44  |

Source: Design Rainfall Tables for El Dorado County prepared by Jim Goodridge, August 30, 2008

**Table A2.2.12 Rainfall Intensity with Return Period of 50 Years**

**El Dorado County Design Rainfall  
Precipitation Intensity (inches per hour) Duration Frequency  
Return Period 50 Years**

| Mean Annual<br>Precipitation | 5 Min | 10 Min | 15 Min | 30 Min | 1 Hr | 2 Hr | 3 Hr | 6 Hr | 12 Hr | 1 Day |
|------------------------------|-------|--------|--------|--------|------|------|------|------|-------|-------|
| 8                            | 0.98  | 0.69   | 0.56   | 0.40   | 0.28 | 0.20 | 0.16 | 0.11 | 0.08  | 0.06  |
| 10                           | 1.22  | 0.86   | 0.70   | 0.49   | 0.35 | 0.25 | 0.20 | 0.14 | 0.10  | 0.07  |
| 12                           | 1.47  | 1.03   | 0.84   | 0.59   | 0.42 | 0.29 | 0.24 | 0.17 | 0.12  | 0.08  |
| 14                           | 1.71  | 1.21   | 0.98   | 0.69   | 0.49 | 0.34 | 0.28 | 0.20 | 0.14  | 0.10  |
| 16                           | 1.96  | 1.36   | 1.12   | 0.79   | 0.56 | 0.39 | 0.32 | 0.23 | 0.16  | 0.11  |
| 18                           | 2.20  | 1.55   | 1.26   | 0.89   | 0.63 | 0.44 | 0.36 | 0.25 | 0.18  | 0.13  |
| 20                           | 2.45  | 1.72   | 1.40   | 0.99   | 0.70 | 0.49 | 0.10 | 0.28 | 0.20  | 0.14  |
| 22                           | 2.69  | 1.90   | 1.55   | 1.09   | 0.77 | 0.54 | 0.44 | 0.31 | 0.22  | 0.15  |
| 24                           | 2.94  | 2.07   | 1.69   | 1.19   | 0.84 | 0.59 | 0.48 | 0.34 | 0.24  | 0.17  |
| 26                           | 3.18  | 2.20   | 1.83   | 1.29   | 0.91 | 0.64 | 0.52 | 0.37 | 0.26  | 0.18  |
| 28                           | 3.43  | 2.41   | 1.97   | 1.38   | 0.98 | 0.69 | 0.56 | 0.39 | 0.28  | 0.20  |
| 30                           | 3.67  | 2.59   | 2.11   | 1.48   | 1.04 | 0.74 | 0.60 | 0.42 | 0.30  | 0.21  |
| 35                           | 4.29  | 3.02   | 2.46   | 1.73   | 1.22 | 0.86 | 0.70 | 0.49 | 0.35  | 0.24  |
| 40                           | 4.90  | 3.45   | 2.81   | 1.98   | 1.39 | 0.98 | 0.80 | 0.56 | 0.40  | 0.28  |
| 45                           | 5.51  | 3.88   | 3.16   | 2.23   | 1.57 | 1.10 | 0.90 | 0.63 | 0.45  | 0.31  |
| 50                           | 6.12  | 4.31   | 3.51   | 2.47   | 1.74 | 1.23 | 1.00 | 0.70 | 0.50  | 0.35  |
| 55                           | 6.73  | 4.74   | 3.86   | 2.72   | 1.92 | 1.35 | 1.10 | 0.77 | 0.54  | 0.38  |
| 60                           | 7.35  | 5.17   | 4.21   | 2.97   | 2.09 | 1.47 | 1.20 | 0.84 | 0.59  | 0.42  |
| 65                           | 7.96  | 5.60   | 4.56   | 3.21   | 2.26 | 1.59 | 1.30 | 0.91 | 0.64  | 0.45  |
| 70                           | 8.57  | 6.04   | 4.92   | 3.46   | 2.44 | 1.72 | 1.40 | 0.98 | 0.69  | 0.49  |

**Source: Design Rainfall Tables for El Dorado County prepared by Jim Goodridge, August 30, 2008**

**Table A2.2.13 Rainfall Intensity with Return Period of 100 Years**

**El Dorado County Design Rainfall  
Precipitation Intensity (inches per hour) Duration Frequency  
Return Period 100 Years**

| Mean Annual<br>Precipitation | 5 Min | 10 Min | 15 Min | 30 Min | 1 Hr | 2 Hr | 3 Hr | 6 Hr | 12 Hr | 1 Day |
|------------------------------|-------|--------|--------|--------|------|------|------|------|-------|-------|
| 8                            | 1.07  | 0.75   | 0.61   | 0.43   | 0.3  | 0.21 | 0.17 | 0.12 | 0.09  | 0.06  |
| 10                           | 1.34  | 0.94   | 0.77   | 0.54   | 0.38 | 0.27 | 0.22 | 0.15 | 0.11  | 0.08  |
| 12                           | 1.60  | 1.13   | 0.92   | 0.65   | 0.46 | 0.32 | 0.26 | 0.18 | 0.13  | 0.09  |
| 14                           | 1.87  | 1.32   | 1.07   | 0.76   | 0.53 | 0.37 | 0.31 | 0.21 | 0.15  | 0.11  |
| 16                           | 2.14  | 1.51   | 1.23   | 0.86   | 0.61 | 0.43 | 0.35 | 0.50 | 0.17  | 0.12  |
| 18                           | 2.41  | 1.69   | 1.38   | 0.97   | 0.68 | 0.48 | 0.39 | 0.28 | 0.19  | 0.14  |
| 20                           | 2.67  | 1.88   | 1.53   | 1.08   | 0.76 | 0.54 | 0.44 | 0.31 | 0.22  | 0.15  |
| 22                           | 2.94  | 2.07   | 1.69   | 1.19   | 0.84 | 0.59 | 0.48 | 0.34 | 0.24  | 0.17  |
| 24                           | 3.21  | 2.26   | 1.84   | 1.30   | 0.91 | 0.64 | 0.52 | 0.37 | 0.26  | 0.18  |
| 26                           | 3.47  | 2.45   | 1.99   | 1.40   | 0.99 | 0.70 | 0.57 | 0.40 | 0.28  | 0.20  |
| 28                           | 3.74  | 2.63   | 2.15   | 1.51   | 1.06 | 0.75 | 0.61 | 0.43 | 0.30  | 0.21  |
| 30                           | 4.01  | 2.82   | 2.30   | 1.62   | 1.14 | 0.80 | 0.65 | 0.46 | 0.32  | 0.23  |
| 35                           | 4.68  | 3.29   | 2.68   | 1.89   | 1.33 | 0.94 | 0.76 | 0.54 | 0.38  | 0.27  |
| 40                           | 5.34  | 3.76   | 3.07   | 2.16   | 1.52 | 1.07 | 0.87 | 0.61 | 0.43  | 0.30  |
| 45                           | 6.01  | 4.23   | 3.45   | 2.43   | 1.71 | 1.20 | 0.98 | 0.69 | 0.49  | 0.34  |
| 50                           | 6.68  | 4.70   | 3.83   | 2.70   | 1.9  | 1.34 | 1.09 | 0.77 | 0.54  | 0.38  |
| 55                           | 7.35  | 5.17   | 4.22   | 2.97   | 2.09 | 1.47 | 1.20 | 0.84 | 0.59  | 0.42  |
| 60                           | 8.02  | 5.65   | 4.60   | 3.24   | 2.28 | 1.61 | 1.31 | 0.92 | 0.65  | 0.46  |
| 65                           | 8.69  | 6.12   | 4.98   | 3.51   | 2.47 | 1.74 | 1.42 | 1.00 | 0.70  | 0.49  |
| 70                           | 9.35  | 6.59   | 5.36   | 3.78   | 2.66 | 1.87 | 1.53 | 1.07 | 0.76  | 0.53  |

**Source: Design Rainfall Tables for El Dorado County prepared by Jim Goodridge, August 30, 2008**



**Table A2.2.14 Rainfall Intensity with Return Period of 1000 Years**

**El Dorado County Design Rainfall  
Precipitation Intensity (inches per hour) Duration Frequency  
Return Period 1000 Years**

| Mean Annual<br>Precipitation | 5 Min | 10 Min | 15 Min | 30 Min | 1 Hr | 2 Hr | 3 Hr | 6 Hr | 12 Hr | 1 Day |
|------------------------------|-------|--------|--------|--------|------|------|------|------|-------|-------|
| 8                            | 1.35  | 0.95   | 0.77   | 0.54   | 0.38 | 0.27 | 0.22 | 0.15 | 0.11  | 0.08  |
| 10                           | 1.69  | 1.19   | 0.97   | 0.68   | 0.48 | 0.34 | 0.28 | 0.19 | 0.14  | 0.10  |
| 12                           | 2.02  | 1.43   | 1.16   | 0.82   | 0.58 | 0.41 | 0.33 | 0.23 | 0.16  | 0.12  |
| 14                           | 2.36  | 1.66   | 1.35   | 0.95   | 0.67 | 0.47 | 0.39 | 0.27 | 0.19  | 0.13  |
| 16                           | 2.70  | 1.90   | 1.55   | 1.09   | 0.77 | 0.54 | 0.44 | 0.31 | 0.22  | 0.15  |
| 18                           | 3.04  | 2.14   | 1.74   | 1.23   | 0.86 | 0.61 | 0.50 | 0.35 | 0.25  | 0.17  |
| 20                           | 3.37  | 2.38   | 1.93   | 1.36   | 0.96 | 0.68 | 0.55 | 0.39 | 0.27  | 0.19  |
| 22                           | 3.71  | 2.61   | 2.13   | 1.50   | 1.06 | 0.74 | 0.61 | 0.43 | 0.30  | 0.21  |
| 24                           | 4.05  | 2.85   | 2.32   | 1.63   | 1.15 | 0.81 | 0.66 | 0.46 | 0.33  | 0.23  |
| 26                           | 4.38  | 3.09   | 2.51   | 1.77   | 1.25 | 0.88 | 0.72 | 0.50 | 0.35  | 0.25  |
| 28                           | 4.72  | 3.33   | 2.71   | 1.91   | 1.34 | 0.95 | 0.77 | 0.54 | 0.38  | 0.27  |
| 30                           | 5.06  | 3.56   | 2.90   | 2.04   | 1.44 | 1.01 | 0.83 | 0.58 | 0.41  | 0.29  |
| 35                           | 5.90  | 4.16   | 3.39   | 2.38   | 1.68 | 1.18 | 0.96 | 0.68 | 0.48  | 0.34  |
| 40                           | 6.75  | 4.75   | 3.87   | 2.72   | 1.92 | 1.35 | 1.10 | 0.77 | 0.55  | 0.38  |
| 45                           | 7.59  | 5.34   | 4.35   | 3.07   | 2.16 | 1.52 | 1.24 | 0.87 | 0.61  | 0.43  |
| 50                           | 8.43  | 5.94   | 4.84   | 3.41   | 2.40 | 1.69 | 1.38 | 0.97 | 0.68  | 0.48  |
| 55                           | 9.28  | 6.53   | 5.32   | 3.75   | 2.64 | 1.86 | 1.51 | 1.07 | 0.75  | 0.53  |
| 60                           | 10.12 | 7.13   | 5.80   | 4.09   | 2.88 | 2.03 | 1.65 | 1.16 | 0.82  | 0.58  |
| 65                           | 10.96 | 7.72   | 6.29   | 4.43   | 3.12 | 2.20 | 1.79 | 1.26 | 0.89  | 0.62  |
| 70                           | 11.81 | 8.31   | 6.77   | 4.77   | 3.36 | 2.36 | 1.93 | 1.36 | 0.95  | 0.67  |

**Source: Design Rainfall Tables for El Dorado County prepared by Jim Goodridge, August 30, 2008**

### **Appendix 2.3 NRCS Curve Number Tables**

The figures and tables in this appendix are copies of figures and tables published in *TR-55*; they are included here for convenience.

According to *TR-55*:

- *Fig. 2-2 is provided to aid in selecting the appropriate figure or table for determining curve numbers.*
- *CN's in table 2-2(a to d) represent average antecedent runoff condition [ARC] for urban, cultivated agricultural, other agricultural, and arid and semiarid rangeland uses.*
- *The CN's in table 2-2 are for the average ARC, which is used primarily for design applications.*

Note also that the CN for urban and residential districts in *TR-55* table 2-2a are based on assumptions regarding the directly-connected impervious area in those districts. These are explained in detail in the footnote to that table. If the catchment of interest does not conform to the conditions stated, it is the responsibility of the engineer to compute appropriate CN and to demonstrate the method of computation.

Urban Hydrology for Small Watersheds, US Department of Agriculture, National Resources Conservation Service – Technical Release 55

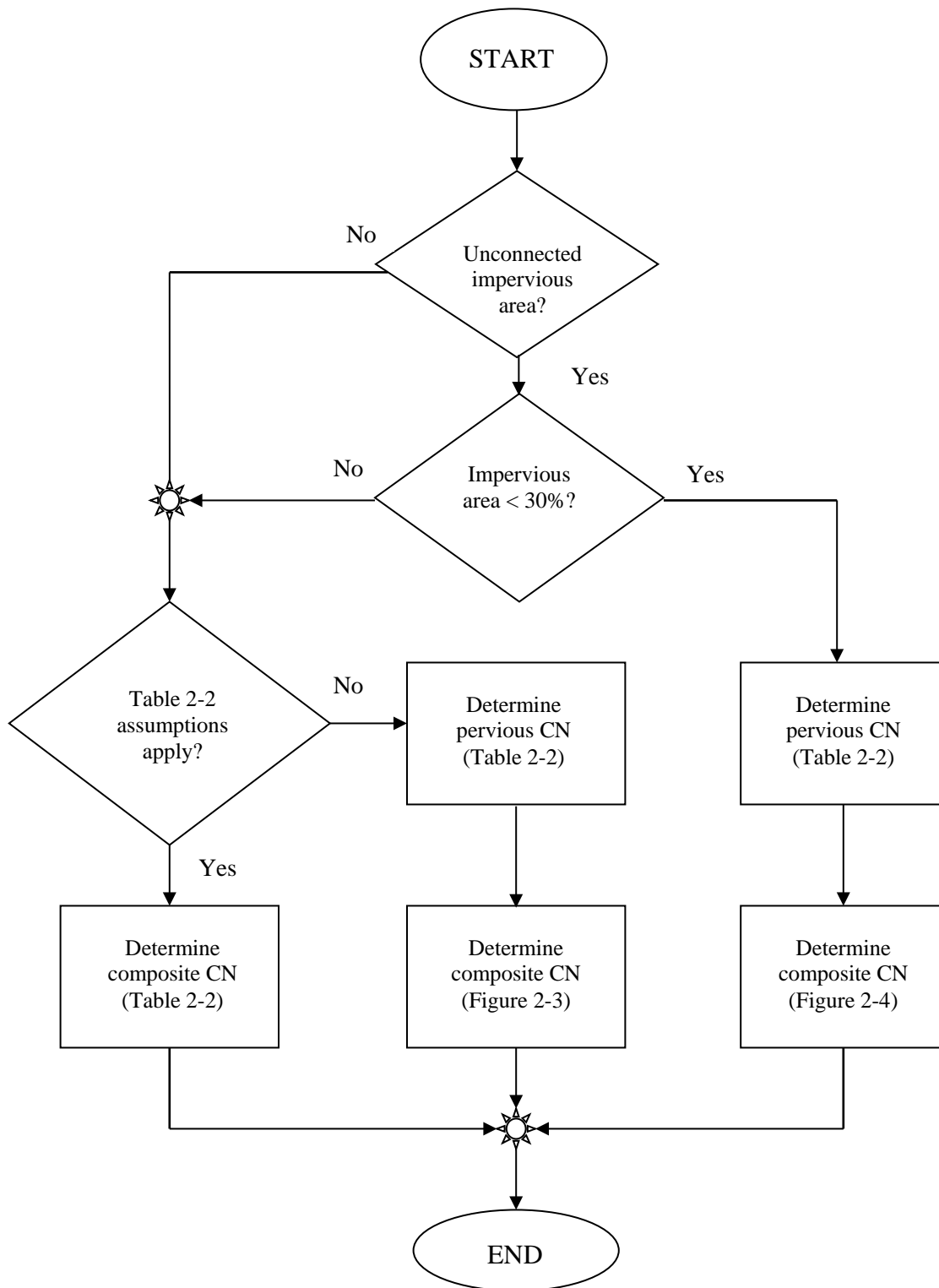


Figure 2-2. – Flow chart for selecting the appropriate figure or table for determining runoff curve numbers.

*Urban Hydrology for Small Watersheds*, US Department of Agriculture, Natural Resources Conservation Service – Technical Release 55

Table 2-2a. – Runoff curve numbers for urban areas<sup>1</sup>

| Cover description   | Average percent impervious area <sup>2</sup> | Curve numbers for hydrologic soil group - |    |    |    |
|---|--|---|----|----|----|
|   |  | A   | B  | C  | D  |
| <i>Fully developed urban areas (vegetation established)</i>   |  |   |    |    |    |
| Open space (lawns, parks, golf courses, cemeteries, etc.) <sup>3</sup> :  |  |   |    |    |    |
| Poor condition (grass cover < 50%).....   | 68   | 79  | 86 | 89 |    |
| Fair condition (grass cover 50% to 75%).....  | 49   | 69  | 79 | 84 |    |
| Good condition (grass cover > 75%).....   | 39   | 61  | 74 | 80 |    |
| Impervious areas:   |  |   |    |    |    |
| Paved parking lots, roofs, driveways, etc. (excluding right-of-way)   |  |   |    |    |    |
|   | 98   | 98  | 98 | 98 |    |
| Streets and roads:  |  |   |    |    |    |
| Paved; curbs and storm sewers (excluding right-of-way).....   | 98   | 98  | 98 | 98 |    |
| Paved; open ditches (including right-of-way).....   | 83   | 89  | 92 | 93 |    |
| Gravel (including right of way).....  | 76   | 85  | 89 | 91 |    |
| Dirt (including right-of-way).....  | 72   | 82  | 87 | 89 |    |
| Western desert urban areas:   |  |   |    |    |    |
| Natural desert landscaping (pervious areas only) <sup>4</sup> .....   |  |   |    |    |    |
|   | 63   | 77  | 85 | 88 |    |
| Artificial desert landscaping (impervious weed barrier, desert shrub with 1- to 2-inch sand or gravel mulch and basin borders)..... |  |   |    |    |    |
|   | 96   | 96  | 96 | 96 |    |
| Urban districts:  |  |   |    |    |    |
| Commercial and business.....  | 85   | 89  | 92 | 94 | 95 |
| Industrial.....   | 72   | 81  | 88 | 91 | 93 |
| Residential districts by average lot size:  |  |   |    |    |    |
| 1/8 acre or less (town houses).....   | 65   | 77  | 85 | 90 | 92 |
| 1/4 acre.....   | 38   | 61  | 75 | 83 | 87 |
| 1/3 acre.....   | 30   | 57  | 72 | 81 | 86 |
| 1/2 acre.....   | 25   | 54  | 70 | 80 | 85 |
| 1 acre.....   | 20   | 51  | 68 | 79 | 84 |
| 2 acres.....  | 12   | 46  | 65 | 77 | 82 |
| <i>Developing urban areas</i>   |  |   |    |    |    |
| Newly graded areas (pervious areas only, no vegetation) <sup>5</sup> .....  |  |   |    |    |    |
|   | 77   | 86  | 91 | 94 |    |
| Idle lands (CN's are determined using cover types similar to those in table 2-2c).  |  |   |    |    |    |

<sup>1</sup>Average runoff condition, and  $I_a = 0.2S$ .

<sup>2</sup>The average percent impervious area shown was used to develop the composite CN's. Other assumptions are as follows: impervious areas are directly connected to the drainage system, impervious areas have a CN of 98, and pervious areas are considered equivalent to open space in good hydrologic condition. CN's for other combinations of conditions may be computed using figure 2-3 or 2-4.

<sup>3</sup>CN's shown are equivalent to those of pasture. Composite CN's may be computed for other combinations of open space cover type.

<sup>4</sup>Composite CN's for natural desert landscaping should be computed using figures 2-3 or 2-4 based on the impervious area percentage (CN = 98) and the pervious area CN. The pervious area CN's are assumed equivalent to desert shrub in poor hydrologic condition.

<sup>5</sup>Composite CN's to use for the design of temporary measures during grading and construction should be computed using figures 2-3 or 2-4, based on the degree of development (impervious area percentage) and the CN's for the newly graded pervious areas.

*Urban Hydrology for Small Watersheds*, US Department of Agriculture, Natural Resources Conservation Service – Technical Release 55

Table 2-2b. – Runoff curve numbers for cultivated agricultural lands<sup>1</sup>

| Cover description                                    |                            |                                   | Curve numbers for hydrologic soil group |    |    |    |
|--|----------------------------|-----------------------------------|---|----|----|----|
| Cover type   | Treatment <sup>2</sup>     | Hydrologic condition <sup>3</sup> | A                                       | B  | C  | D  |
| Fallow   | Bare Soil                  | --                                | 77                                      | 86 | 91 | 94 |
|  | Crop residue cover (CR)    | Poor                              | 76                                      | 85 | 90 | 93 |
|  |                            | Good                              | 74                                      | 83 | 88 | 90 |
| Row Crops  | Straight row (SR)          | Poor                              | 72                                      | 81 | 88 | 91 |
|  |                            | Good                              | 67                                      | 78 | 85 | 89 |
|  | SR + CR                    | Poor                              | 71                                      | 80 | 87 | 90 |
|  |                            | Good                              | 64                                      | 75 | 82 | 85 |
|  | Contoured ( C )            | Poor                              | 70                                      | 79 | 84 | 88 |
|  |                            | Good                              | 65                                      | 75 | 82 | 86 |
|  | C + CR                     | Poor                              | 69                                      | 78 | 83 | 87 |
|  |                            | Good                              | 64                                      | 74 | 81 | 85 |
|  | Contoured & terraced (C&T) | Poor                              | 66                                      | 74 | 80 | 82 |
|  |                            | Good                              | 62                                      | 71 | 78 | 81 |
|  | C&T + CR                   | Poor                              | 65                                      | 73 | 79 | 81 |
|  |                            | Good                              | 61                                      | 70 | 77 | 80 |
| Small grain  | SR                         | Poor                              | 65                                      | 76 | 84 | 88 |
|  |                            | Good                              | 63                                      | 75 | 83 | 87 |
|  | SR + CR                    | Poor                              | 64                                      | 75 | 83 | 86 |
|  |                            | Good                              | 60                                      | 72 | 80 | 84 |
|  | C                          | Poor                              | 63                                      | 74 | 82 | 85 |
|  |                            | Good                              | 61                                      | 73 | 81 | 84 |
|  | C + CR                     | Poor                              | 62                                      | 73 | 81 | 84 |
|  |                            | Good                              | 60                                      | 72 | 80 | 83 |
|  | C&T                        | Poor                              | 61                                      | 72 | 79 | 82 |
|  |                            | Good                              | 59                                      | 70 | 78 | 81 |
|  | C&T + CR                   | Poor                              | 60                                      | 71 | 78 | 81 |
|  |                            | Good                              | 58                                      | 69 | 77 | 80 |
| Close-seeded or broadcast legumes or rotation meadow | SR                         | Poor                              | 66                                      | 77 | 85 | 89 |
|  |                            | Good                              | 58                                      | 72 | 81 | 85 |
|  | C                          | Poor                              | 64                                      | 75 | 83 | 85 |
|  |                            | Good                              | 55                                      | 69 | 78 | 83 |
|  | C&T                        | Poor                              | 63                                      | 73 | 80 | 83 |
|  |                            | Good                              | 51                                      | 67 | 76 | 80 |

<sup>1</sup>Average runoff condition, and  $I_a = 0.2S$ .

<sup>2</sup>Crop residue cover applies only if residue is on at least 5% of the surface throughout the year.

<sup>3</sup>Hydrologic condition is based on combination of factors that affect infiltration and runoff, including (a) density and canopy of vegetative areas, (b) amount of year-round cover, (c) amount of grass or close-seeded legumes in rotations, (d) percent of residue cover on the land surface (good  $\geq 20\%$ ), and (e) degree of surface roughness.

*Poor:* Factors impair infiltration and tend to increase runoff.

*Good:* Factors encourage average and better than average infiltration and tend to decrease runoff.

*Urban Hydrology for Small Watersheds*, US Department of Agriculture, Natural Resources Conservation Service – Technical Release 55

Table 2-2c – Runoff curve numbers for other agricultural lands<sup>1</sup>

| Cover description  |                      | Curve numbers for hydrologic soil group |    |    |    |
|--|----------------------|---|----|----|----|
| Cover type   | Hydrologic condition | A                                       | B  | C  | D  |
| Pasture, grassland, or range-continuous forage for grazing. <sup>2</sup>     | Poor                 | 68                                      | 79 | 86 | 89 |
|  | Fair                 | 49                                      | 69 | 79 | 84 |
|  | Good                 | 39                                      | 61 | 74 | 80 |
| Meadow-continuous grass, protected from grazing and generally mowed for hay. | --                   | 30                                      | 58 | 71 | 78 |
| Brush--brush-weed-grass mixture with brush the major element. <sup>3</sup>   | Poor                 | 48                                      | 67 | 77 | 83 |
|  | Fair                 | 35                                      | 56 | 70 | 77 |
|  | Good                 | <sup>4</sup> 30                         | 48 | 65 | 73 |
| Woods--grass combination (orchard or tree farm). <sup>5</sup>                | Poor                 | 57                                      | 73 | 82 | 86 |
|  | Fair                 | 43                                      | 65 | 76 | 82 |
|  | Good                 | 32                                      | 58 | 72 | 79 |
| Woods. <sup>6</sup>  | Poor                 | 45                                      | 66 | 77 | 83 |
|  | Fair                 | 36                                      | 60 | 73 | 79 |
|  | Good                 | <sup>4</sup> 30                         | 55 | 70 | 77 |
| Farmsteads--buildings, lanes, driveways, and surrounding lots.               | --                   | 59                                      | 74 | 82 | 86 |

<sup>1</sup>Average runoff condition, and  $I_a = 0.2S$ .

<sup>2</sup>*Poor:* <50% ground cover or heavily grazed with no mulch.  
*Fair:* 50 to 75% ground cover and not heavily grazed.  
*Good:* >75% ground cover and lightly or only occasionally grazed.

<sup>3</sup>*Poor:* <50% ground cover.  
*Fair:* 50 to 75% ground cover.  
*Good:* >75% ground cover.

<sup>4</sup>Actual curve number is less than 30: use CN = 30 for runoff computations.

<sup>5</sup>CN's shown were computed for areas with 50% woods and 50% grass (pasture) cover. Other combinations of conditions may be computed from the CN's for woods and pasture.

<sup>6</sup>*Poor:* Forest litter, small trees, and brush are destroyed by heavy grazing or regular burning.  
*Fair:* Woods are grazed but not burned, and some forest litter covers the soil.  
*Good:* Woods are protected from grazing, and litter and brush adequately cover the soil.

*Urban Hydrology for Small Watersheds*, US Department of Agriculture, Natural Resources Conservation Service – Technical Release 55

Table 2-2d – Runoff curve numbers for arid and semiarid rangelands<sup>1</sup>

| Cover description   |                                   | Curve numbers for hydrologic soil group |    |    |    |
|---|-----------------------------------|---|----|----|----|
| Cover type  | Hydrologic condition <sup>2</sup> | A <sup>3</sup>                          | B  | C  | D  |
| Herbaceous--mixture of grass, weeds, and low-growing brush, with brush the minor element.                                     | Poor                              |   | 80 | 87 | 93 |
|   | Fair                              |   | 71 | 81 | 89 |
|   | Good                              |   | 62 | 74 | 85 |
| Oak-aspen--mountain brush mixture of oak brush, aspen, mountain mahogany, bitter brush, maple, and other brush.               | Poor                              |   | 66 | 74 | 79 |
|   | Fair                              |   | 48 | 57 | 63 |
|   | Good                              |   | 30 | 41 | 48 |
| Pinyon-juniper--pinyon, juniper, or both; grass understory.   | Poor                              |   | 75 | 85 | 89 |
|   | Fair                              |   | 58 | 73 | 80 |
|   | Good                              |   | 41 | 61 | 71 |
| Sagebrush with grass understory.  | Poor                              |   | 67 | 80 | 85 |
|   | Fair                              |   | 51 | 63 | 70 |
|   | Good                              |   | 35 | 47 | 55 |
| Desert shrub--major plants include saltbush, greasewood, creosotebush, blackbrush, bursage, palo verde, mesquite, and cactus. | Poor                              | 63                                      | 77 | 85 | 88 |
|   | Fair                              | 55                                      | 72 | 81 | 86 |
|   | Good                              | 49                                      | 68 | 79 | 84 |

<sup>1</sup>Average runoff condition, and  $I_a = 0.2S$ . For range in humid regions, use table 2-2c.

<sup>2</sup>*Poor*: <30% ground cover (litter, grass, and brush overstory).

*Fair*: 30 to 70% ground cover.

*Good*: >70% ground cover.

<sup>3</sup>Curve numbers for group A have been developed only for desert shrub.

Urban Hydrology for Small Watersheds, US Department of Agriculture, Natural Resources Conservation Service – Technical Release 55

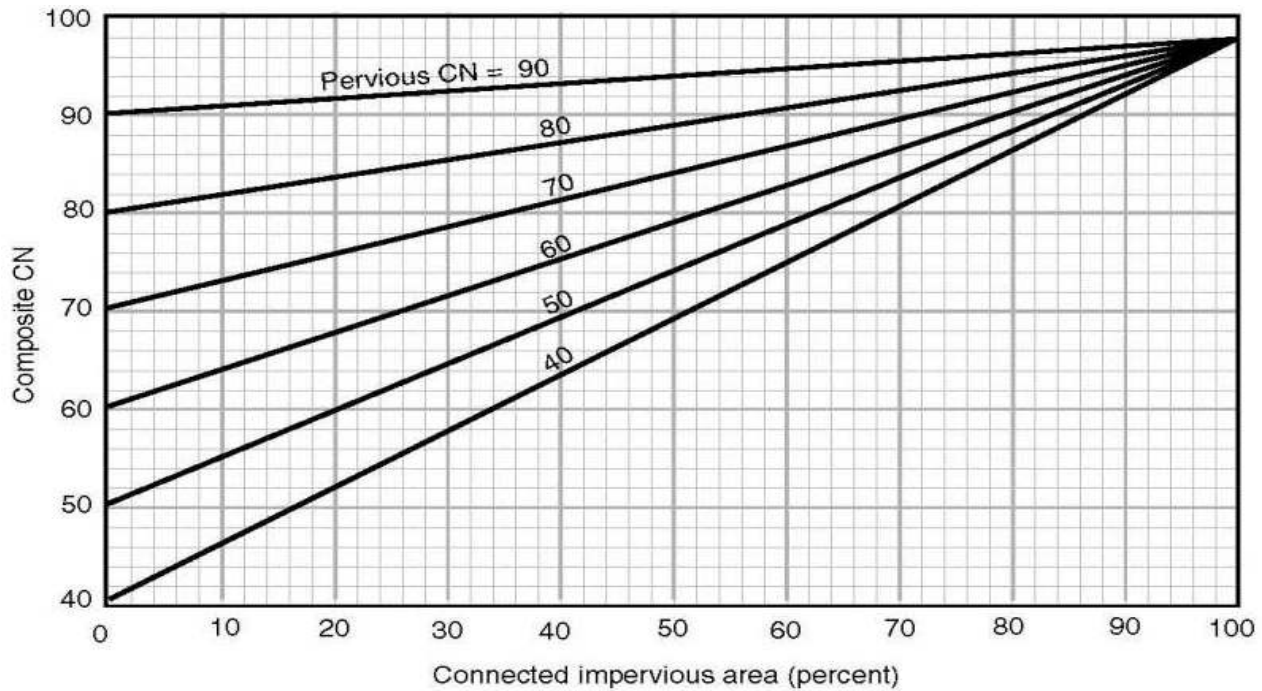


Figure 2-3. – Composite CN with connected impervious area.

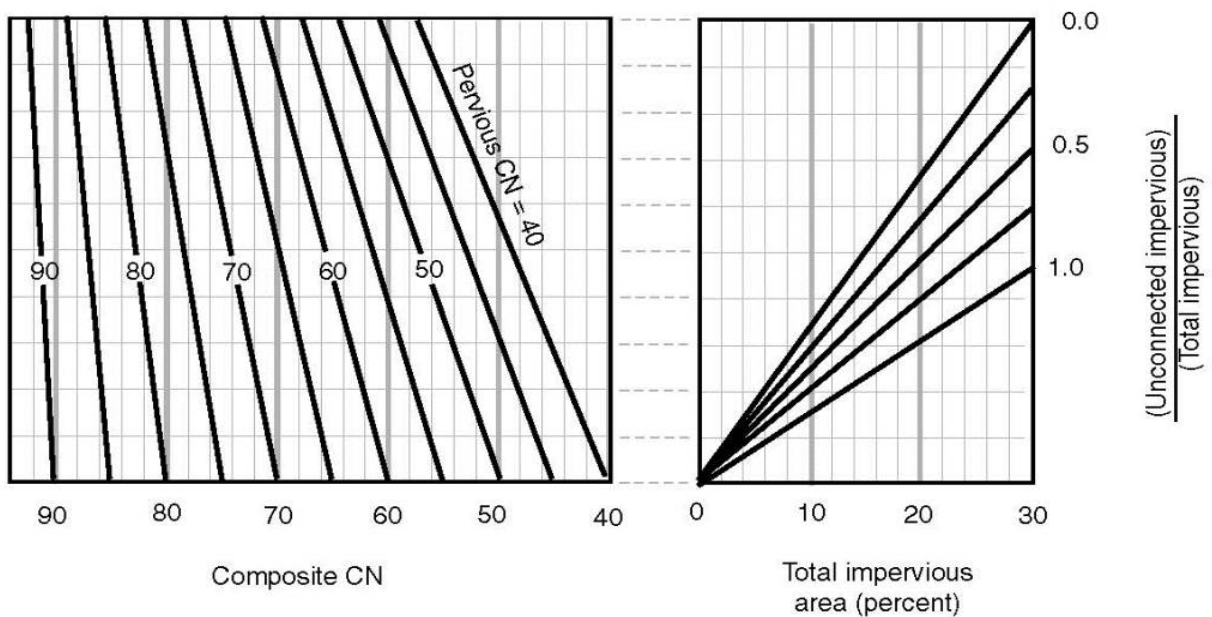


Figure 2-4. – Composite CN with unconnected impervious areas and total impervious area less than 30%.



## **Appendix 2.4 USGS Regional Frequency Estimates**

The USGS regional regression equations for rural catchments in the Sierra region are shown in Table A2.4.1 (Barth, et al, 2012<sup>9</sup>). In this table, A = drainage area, in sq mi, determined with the best available topographic map; P = mean annual precipitation, in in.; H = altitude index, in thousands ft, computed as the average of altitudes at points along the main channel of the stream 10 and 85% of the distance from the point of interest to the catchment boundary.

The equations were developed for rural catchments where overall impervious areas within the catchments is less than 10% of the total catchment area. It is strongly suggested that the Hydrograph Method as earlier described be used in urbanized areas.

**Table A2.4.1 USGS Regional Flood-Frequency Equations**  
(Source: USGS, 2012)

| <b>Return period,<br/>in years<br/>(1)</b> | <b>Rural peak,<br/>in cfs<br/>(2)</b> |
|--|---------------------------------------|
| 2  | $2.43 A^{0.924} P^{2.06} H^{-0.646}$  |
| 10   | $17.2 A^{0.896} P^{1.54} H^{-0.486}$  |
| 100  | $20.6 A^{0.874} P^{1.24} H^{-0.25}$   |

---

<sup>9</sup> The 1977 USGS' *Water-Resources Investigations 77-21* has been replaced by Scientific Investigations Report (SIR) 2012-5113 in 2012. See Appendix 2.1.1 for updated references.

**Appendix 2.5 HEC-1 Input Example**

For illustration, an HEC-1 input file with records necessary to compute the runoff due to a 24-hr design storm with the hydrograph procedure endorsed by El Dorado County is shown in Fig. A2.5.1. This example is for a 5 sq mi catchment near Rescue, CA. The time of concentration is one hour, and the CN is 70.

|  |        |       |       |       |       |       |       |       |       |       |
|--|--------|-------|-------|-------|-------|-------|-------|-------|-------|-------|
| ID Example: Hypothetical 5 sq mi catchment near Rescue, CA, w/ MAP=30" |        |       |       |       |       |       |       |       |       |       |
| IT   | 10     | 300   |       |       |       |       |       |       |       |       |
| KK   | Rescue |       |       |       |       |       |       |       |       |       |
| BA   | 5      |       |       |       |       |       |       |       |       |       |
| *Depth of 100-yr 24-hr rainfall  |        |       |       |       |       |       |       |       |       |       |
| PB   | 5.82   |       |       |       |       |       |       |       |       |       |
| *PC records for NRCS 24-hr storm, type 1A, from TR-20                  |        |       |       |       |       |       |       |       |       |       |
| IN   | 30     |       |       |       |       |       |       |       |       |       |
| PC   | 0      | 0.01  | 0.022 | 0.036 | 0.051 | 0.067 | 0.083 | 0.099 | 0.116 | 0.135 |
| PC   | 0.156  | 0.179 | 0.204 | 0.233 | 0.268 | 0.31  | 0.425 | 0.48  | 0.52  | 0.55  |
| PC   | 0.577  | 0.601 | 0.623 | 0.644 | 0.664 | 0.683 | 0.701 | 0.719 | 0.736 | 0.753 |
| PC   | 0.769  | 0.785 | 0.8   | 0.815 | 0.83  | 0.844 | 0.858 | 0.871 | 0.884 | 0.896 |
| PC   | 0.908  | 0.92  | 0.932 | 0.944 | 0.956 | 0.967 | 0.978 | 0.989 | 1     |       |
| UD   | 0.60   |       |       |       |       |       |       |       |       |       |
| LS   | 70     |       |       |       |       |       |       |       |       |       |
| ZZ   |        |       |       |       |       |       |       |       |       |       |

**FIG. A2.5.1 HEC-1 Input Example**

This input is included to illustrate the method in which the design-storm rainfall data are specified and to bring the following critical points to the attention of any engineers using this program for stormwater analysis in El Dorado County:

*IT record:* The time step for computation is specified in the first field on this record. This value must be sufficiently small to permit adequate definition of the rising limb of the UH. The time of rise is a function of the catchment lag. Consequently, the appropriate time step is related to the catchment lag. Following the recommendation of the HEC, the computation time step should be less than 29% of the lag. In this example, that is 29% of 60% of 1 hr, so 10 min. is selected. The number of runoff hydrograph ordinates to be computed is specified also on the IT record. The value here must be sufficient to permit simulation of runoff from the entire rain storm. For example, with a 24-hr storm and a 10-min interval, at least 144 ordinates are required just to simulate the duration of the rainfall; additional ordinates are required to simulate runoff after the rain ends. In this example, 300 ordinates are specified; this is the maximum permitted with the "standard" version of the program. Because of this limitation, if runoff from a 24-hr

storm is to be simulated with a short time interval, the engineer must obtain and use an extended memory version of the program.

*PB record:* The design storm depth, in in., is specified on this record. This is the catchment-average depth, with appropriate adjustments.

*PC records:* These records provide the temporal distribution pattern for the design storm. In this case, the 24-hr NRCS storm is specified. The time interval between successive values is specified on the IN record.

*LS record:* The composite CN is specified in the second field of this record. In this example, it is 70 and is specified in the second field. The program user may, in the first field, specify the initial abstraction,  $I_a$ . If the field is left blank, the program assigns  $I_a = 0.2S$ , which is appropriate, according to Donald Woodward, P.E. of the U.S. Department of Agriculture in a presentation at ASCE Water Forum 1992. Woodward indicated that the CN tables in *TR-55* are based on this key assumption. Further, he indicated that if the assumption is not valid, the tables should not be used; instead specific CN tables should be developed with the alternative relationship. Insufficient data exist to do so in El Dorado County, so  $I_a$  is assumed equal  $0.2S$ . The third field of this record is available to specify the percentage of rainfall that runs off without infiltration, interception, etc. However, if the CN tables from *TR-55* are used, the directly-connected impervious area is accounted for already in the CN estimates.

*UD record:* The catchment lag, in hr, is specified on this record.

**Section  
3**

**Surface Drainage Design**

This section discusses the analysis procedures and design criteria for surface drainage improvements in El Dorado County.

**Contents of this section**

- 3.1 Background..... 3-2
- 3.2 Analysis Procedures ..... 3-2
  - 3.2.1 Sub-Area Runoff ..... 3-3
  - 3.2.2 Street Flow Hydraulics ..... 3-3
  - 3.2.3 Inlet Analysis..... 3-4
  - 3.2.4 Inlet for Sump Conditions..... 3-6
  - 3.2.5 Analysis Steps ..... 3-7
  - 3.2.6 100-Year Peak Flow Analysis ..... 3-8
- 3.3 Design Criteria ..... 3-9
  - 3.3.1 Overland Flow Criteria ..... 3-9
  - 3.3.2 Recommended Minimum Surface Grades ..... 3-9
  - 3.3.3 Fencing ..... 3-10
  - 3.3.4 Back of Lot Swales and Other Ditches..... 3-10
  - 3.3.5 Flow on Streets ..... 3-10
- Appendix 3.1 References..... 3-12
  - Appendix 3.1.1 Updated References ..... 3-13

### **3.1 Background**

The purpose of this section is to address the analysis of runoff that drains onto or across improved surfaces. Such surfaces include streets, residential and commercial lots, natural hill slopes, and graded cut or fill slopes. Runoff from a residential lot, for example, might be conveyed to the street, and then into storm drains via curb inlets. The storm drain would then convey the water into a natural or improved channel.

This section describes the runoff conveyance process starting with the peak flow computed using the procedures in Section 2.4 or 2.5 and ending with the water reaching an appropriately sized storm drain inlet. Section 4 describes the design of closed conduits into which feed the storm drain inlets. Section 6 describes the design of open channels which, in general, receive water from one or more storm drain pipes.

### **3.2 Analysis Procedures**

The types of surface flow covered by this section include: 1) runoff from improved surfaces, 2) runoff from contributory unimproved surfaces, 3) street flow, and 4) storm drain inlet flow. The analysis procedures described here provide a framework for the designer to incorporate adequate surface drainage into a proposed development. The objective is to safely convey surface runoff to the planned drainage facilities. Once the required analysis has been done, the designer's work is not complete until the following issues are adequately accounted for in the overall design.

1. The potential for erosion and gully formation are minimized.
2. Excessive sheet flow velocities or depths are avoided.
3. Areas with sluggish drainage or excessive ponding are eliminated.
4. For building pads, the preferred location for roof drainage gutters should be indicated on the grading or drainage plans.

### 3.2.1 Sub-Area Runoff

Each storm drain inlet has a contributing drainage area. Hydrologic calculations are often performed on catchment areas that are larger than individual storm drain inlet sub-areas. If this is the case, the design peak flow for a given storm drain inlet can be determined from the following equation:

$$Q_i = Q_t \left( \frac{A_i}{A_t} \right) \quad (\text{Eq. 3.2.1})$$

in which  $Q_i$  = the peak discharge for a given inlet;  $Q_t$  = the peak discharge for the total catchment area computed using the methods in Sections 2.4 or 2.5;  $A_i$  = the drainage area contributing to a given inlet; and  $A_t$  = the total catchment area upon which  $Q_t$  is based.

### 3.2.2 Street Flow Hydraulics

The discharge in a simple or compound street section can be determined from Charts 3 and 4 of *Drainage of Highway Pavements*, (Federal Highway Administration, 1984<sup>10</sup>). Relationships for the discharge capacity of typical El Dorado County street half sections can be developed from these charts. These equations are only for use with streets that have a 2% cross slope from crown to curb and an effective Manning's  $n$  value of 0.015. Flow depths are constrained such that there is no overtopping of the curb, and inundation extends no more than 16 feet into the street. If inundation is less than 16 ft, use the equations found in Chapter 4 entitled "Pavement Drainage", of *HEC-22* (2013).

For streets with a Type 1 rolled curb and gutter with a maximum flow depth of 0.3 feet:

$$Q = 22(\sqrt{S}) \quad (\text{Eq. 3.2.2})$$

For streets with a Type 2 vertical curb and gutter with a maximum depth of 0.4 feet:

$$Q = 73(\sqrt{S}) \quad (\text{Eq. 3.2.3})$$

---

<sup>10</sup> The *Drainage of Highway Pavements* (HEC-12) has been superseded by HEC-22. See Appendix 3.1.1 for updated references.

For streets with A.C. barrier curbs with a maximum depth of 0.3 feet:

$$Q = 75(\sqrt{S}) \quad (\text{Eq. 3.2.4})$$

in which Q is the street capacity in cfs, and S is the slope of the street in ft/ft.

### **3.2.3 Inlet Analysis**

Inlets are used to convey surface runoff to closed conduit systems. Inlets are often constructed with a slight local depression in order to capture runoff efficiently. Inlets placed on a continuous grade are usually designed to allow some bypass runoff. Curb and gutter inlets are relatively inefficient. If the likelihood of blockage exists, additional curb inlets should be installed. Volume V of the El Dorado County *Design and Improvement Standards Manual* contains details of two types of commonly used curb inlets and one type of commonly used area drain inlet.

The first curb inlet is the Caltrans Type B Drop Inlet. This inlet allows water to drop down directly into the catch basin. A metal grate is placed over the opening. In cases where certain safety issues are present, the type of grate used may need to be modified. For example, The Federal Highway Administration – formerly the Bureau of Public Roads (1978) describes a bicycle safe grate.

The capacity of a standard 3' wide Type B Drop Inlet is shown in Table 3.2.1. Two capacities are shown. The first is for the case when the entire design runoff must enter the inlet. For example, if the street grade is 4%, and all of the runoff must enter the grate, a Type B Drop Inlet must be placed when the design runoff is expected to reach 1.6 cfs. The second list of capacities is for the case when some bypass flow is allowed. These data assume a 20% bypass flow. So, for example, assuming the same 4% street grade, 3.7 cfs will enter the inlet if bypass is allowed. In this example, a Type B Inlet must be placed when the total design flow is 4.6 cfs thus allowing 3.7 cfs to enter the inlet and 0.9 cfs to continue to the next inlet.

**Table 3.2.1 Capacity for Standard Type B Drop Inlet (3' Wide)**  
 (Source: Psomas and Associates, 1991)

| Slope of Road (%) | Inlet Capacity for 100% of flow Entering Inlet (cfs) | Inlet Capacity for 80% of flow Entering Inlet and 20% of flow Bypassing Inlet (cfs) |
|-------------------|--|---|
| 0.5               | 1.0  | 1.4   |
| 1.0               | 1.1  | 2.0   |
| 1.5               | 1.2  | 2.5   |
| 2.0               | 1.3  | 3.0   |
| 2.5               | 1.4  | 3.2   |
| 3.0               | 1.5  | 3.4   |
| 4.0               | 1.6  | 3.7   |
| 5.0               | 1.7  | 3.9   |
| 6.0               | 1.7  | 4.1   |
| 7.0               | 1.8  | 4.2   |
| 8.0               | 1.8  | 4.3   |
| 9.0               | 1.9  | 4.3   |
| 10.0              | 1.9  | 4.2   |
| 11.0              | 1.9  | 4.2   |
| 12.0              | 2.0  | 4.1   |
| 13.0              | 2.0  | 4.1   |
| 14.0              | 2.0  | 4.0   |
| 15.0              | 2.0  | 4.0   |

The second curb inlet is the Pelican Gallery Inlet. This inlet allows water to enter through an opening in the curb.

The capacity of a standard 11' wide Pelican Gallery Inlet is shown in Table 3.2.2. Two capacities are shown (Psomas and Associates, 1991). The first is for the case when the entire design runoff must enter the inlet. For example, if the street grade is 4%, and all of the runoff must enter the grate, a Pelican Gallery Inlet must be placed when the design runoff is expected to reach 4.6 cfs. The second list of capacities is for the case when some bypass flow is allowed. These data assume a 20% bypass flow. So, for example, assuming the same 4% street grade, 8.8 cfs will enter the inlet if bypass is allowed. In this example, a Pelican Inlet must be placed when the total design flow is 11.0 cfs thus allowing 8.8 cfs to enter the inlet and 2.2 cfs to continue to the next inlet.



**Table 3.2.2 Capacity for Pelican Gallery Inlet (11' Wide)**  
**(Source: Psomas and Associates, 1991)**

| Slope of Road (%) | Inlet Capacity for 100% of flow Entering Inlet (cfs) | Inlet Capacity for 80% of flow Entering Inlet and 20% of flow Bypassing Inlet (cfs) |
|-------------------|--|---|
| 0.5               | 5.8  | 7.5   |
| 1.0               | 5.8  | 8.0   |
| 1.5               | 5.8  | 8.5   |
| 2.0               | 5.8  | 8.9   |
| 2.5               | 5.7  | 9.2   |
| 3.0               | 5.5  | 9.2   |
| 4.0               | 4.6  | 8.8   |
| 5.0               | 3.5  | 8.0   |
| 6.0               | 2.2  | 7.2   |
| 7.0               | 1.5  | 6.3   |
| 8.0               | 1.1  | 5.2   |
| 9.0               | 1.0  | 3.9   |
| 10.0              | 0.8  | 3.2   |
| 11.0              | 0.7  | 3.0   |
| 12.0              | 0.7  | 2.8   |
| 13.0              | 0.7  | 2.8   |
| 14.0              | 0.7  | 2.8   |
| 15.0              | 0.7  | 2.8   |

The third inlet is the Grated Inlet. The purpose of this inlet is to drain areas such as fields and lots. No overflow is usually allowed.

**3.2.4 Inlet for Sump Conditions**

For sump conditions, the inlet capacity for the Type B Drop Inlet is given by Psomas and Associates (1991). Often more than one inlet is placed side by side in a sump if additional capacity is required. The capacity of a Type B Drop Inlet under sump conditions is shown in Table 3.2.3.

**Table 3.2.3 Capacity for Type B Inlet under Sump Conditions**  
**(Source: Psomas and Associates, 1991)**

| Number of 3' long Type B Inlet Segments | Inlet Capacity (cfs) |
|---|----------------------|
| 1                                       | 13                   |
| 2                                       | 26                   |
| 3                                       | 39                   |
| 4                                       | 52                   |
| 5                                       | 65                   |

### **3.2.5 Analysis Steps**

This section provides a suggested procedure for determining the size and number of inlets for street drainage. The design is based on the 10-year peak flow. The design should also be evaluated for the 100-year peak flow to insure that if the pipe flow system malfunctions, or its capacity is exceeded, flow depths will still be at least 1 foot below the finish floor elevation of adjacent structures.

1. For a given sub-basin, layout the streets. Determine the general drainage layout. Determine the approximate location of storm drain inlets, sump locations, and street drainage patterns. This step requires some judgment and experience in order to do it correctly on the first attempt.
2. Determine the sub-basin area  $A_t$ , the 10-year peak runoff  $Q_t$ , and the 100-year peak runoff using the methods described in Sections 2.4 or 2.5.
3. Since one sub-basin may contain several inlets, the drainage area  $A_i$  and peak flow  $Q_i$  for each inlet must be determined. This is done by using Equation 3.2.1. If a single sub-basin has 10 or more inlets, consideration should be given to breaking it up into smaller sub-basins. Start with the first inlet.
4. Determine the slope of the street that drains to the inlet.
5. Using equation 3.2.2, 3.2.3, or 3.2.4, check the half street capacity using the slope from Step 3.
6. The street capacity should be greater than the total 10-year peak just upstream of the inlet being evaluated. If the 10-year flow exceeds the half street capacity, the inlet needs to be moved upstream.
7. Determine the inlet capacity using Table 3.2.1 for a Standard Type B Drop Inlet, Table 3.2.2 for a Pelican Gallery Inlet, or Table 3.2.3 for a Type B inlet under sump conditions. Use the appropriate column in the table depending on whether the design is based on 100% interception or 80% interception.
8. If the design is based on 100% interception, verify that the total flow upstream from the inlet is less than or equal to the inlet capacity determined in Step 6. Once the flow enters the inlet, it is considered pipe flow  $Q_p$ . If the design is based on 80% interception, verify that 0.80 times the total flow upstream from the inlet does not exceed the

capacity determine in Step 6. Determine the amount of bypass flow  $Q_b$  by subtracting the inlet capacity from the total upstream of the inlet.

9. Add the pipe inflow  $Q_p$  from Step 7 to the total pipe flow coming in from upstream. Verify that the total flow does not exceed the capacity of the main line drainage pipe under gravity flow conditions.
10. Add the bypass flow  $Q_b$  to the contributing runoff for the next downstream inlet,  $Q_i$ . This is the total flow used to evaluate the next inlet and street capacity. At this point, go back to Step 3 and repeat the process. Continue the process until all the inlet areas  $A_i$  have been analyzed.
11. When a sump condition is reached, verify that the capacity of the sump is greater than or equal to the total 100-year runoff as described in Section 3.3.5.

The calculations above lend themselves to a tabular format with 10 columns (one for each step). Specific conditions of the calculations may require various formats for the computation table. Furthermore, additional computations not described above may be required.

### **3.2.6 100-Year Peak Flow Analysis**

Streets and their associated underground drainage pipes must convey the 100-year runoff such that the water surface elevation is at least 1 foot below the finish floor of adjacent structures. Although it is possible to determine the 100-year flow behavior in a tabular manner as described in Section 3.2.5, difficulties often arise since larger events usually result in flows going completely across the roadway.

EI Dorado County therefore recommends that standard step backwater computations (See Section 6) or the equivalent be performed on proposed streets in order to determine the 100-year water surface elevation.

The cross section should include the entire street, curb, sidewalk, and adjacent areas that will always have free conveyance of flows. The cross section shapes are shown in Volume V of the EI Dorado County *Design and Improvement Standards Manual*.

For streets with storm drain systems, the proper discharge to use for a given street section is:

$$Q_{100,Street} = Q_{100} - Q_{10,Pipe} \quad (\text{Eq. 3.2.5})$$

in which  $Q_{100,Street}$  = The 100-year flow to use for street conveyance evaluation;  $Q_{100}$  = The total 100-year peak flow for the drainage area contributing to that street cross section;  $Q_{10,Pipe}$  = The total pipe flow at that street cross section from the 10-year analysis in Section 3.2.5.

As part of this analysis, the engineer should consider the overall safety of adjacent developments. This process includes understanding what happens for events larger than the 100-year, and also what happens if critical drainage devices become blocked with debris. Drainage overflow points or secondary outlets that anticipate such occurrences should be designed into the overall drainage system.

### **3.3 Design Criteria**

This section describes the criteria that should be used when designing surface drainage systems in El Dorado County. The objective is to provide safe, reliable drainage for improved areas. The analysis procedures described in Section 3.2 should serve as guidance for correctly interpreting and implementing the design criteria. It is the responsibility of the engineer to combine general drainage principles and practices with the procedures described in Section 3 in order to develop a functional drainage plan that is acceptable to El Dorado County.

#### **3.3.1 Overland Flow Criteria**

Design of improvements should retain the general pattern of surface flow prior to development. The peak water surface from the 100-year peak flow should be a least one foot below the finish floor of all adjacent structures. On site ponding should not occur unless it is part of a detention basin.

#### **3.3.2 Recommended Minimum Surface Grades**

The purpose of minimum gradients is to preserve the design drainage characteristics over the long term accounting for settlement, sediment deposits, seismic movement, etc. The minimum slopes for surface drainage design are shown in Table 3.4.1.

**Table 3.4.1 Recommended Minimum Surface Drainage Slopes  
(Source: Psomas and Associates, 1991)**

| Description of Surface                       | Minimum Slope |
|--|---------------|
| Grass and Landscape Cross Slope              | 2%            |
| Grass, Earth or Rock Drainage Swales         | 2%            |
| AC Pavement Cross Slope or Concrete Swale    | 2%            |
| Concrete Surface or Standard Curb and Gutter | 1%            |

In some cases, street and curb grades may be allowed to be as low as 0.5% if approved by El Dorado County. This is to be used only for short stretches in non-critical areas. For areas where the extensive use of drainage slopes less than 1% is proposed, El Dorado County may request that the drainage system be redesigned to accommodate steeper grades.

**3.3.3 Fencing**

Fencing or any other surface improvements should be designed so that it does not obstruct flow on critical slopes, drainage swales, lot side drainage, etc.

**3.3.4 Back of Lot Swales and Other Ditches**

When more than one lot contributes to a swale or ditch before discharging into a public facility, adequate design analysis must be provided to show that it will convey the 100-year peak flow at a water surface elevation at least one foot lower than the finish floor elevation of adjacent structures. It should also be constructed following the criteria in Section 6.

**3.3.5 Flow on Streets**

Commercial and Industrial Roadways and Class 1 Subdivision Roadways shall maintain flows at or below the top of curb and shall not extend out into the roadway a distance equal to 2/3 of the half-width when conveying the 10-year peak flow. The maximum distance between street drainage inlets is 500 feet.

In addition, driveways must be designed such that flow depths equal to the curb height do not result in significant ponding on sidewalks. In the case of downslope driveways, flow depths equal to the curb height should not

overtop the driveway crest. Provisions for overtopping during larger events must be made.

Roadways constructed with AC dikes or barrier curbs shall meet the requirements of a maximum flow width of  $\frac{2}{3}$  the street half-width for the 10 year design storm runoff.

The 100-year peak flow water surface elevation should be at least 1 foot lower than the finish floor of adjacent structures. The effects of the 100-year storm runoff should be analyzed throughout the entire drainage system. Where practical, the velocity-depth product should be less than or equal to  $6 \text{ ft}^2/\text{sec}$ .

Sump inlets should be designed to convey the 100-year excess runoff. Additional consideration should be given to the design of overflow points or secondary outlets should the sump inlet malfunction.

### **Appendix 3.1 References**

County of El Dorado (1990). *Design and Improvement Standards Manual*. Placerville, CA.

Federal Highway Administration (1984). "Drainage of Highway Pavements," *Hydraulic Engineering Circular No. 12 (HEC-12)*. Washington, D.C.

Federal Highway Administration (1978). "Hydraulic and Safety Characteristics of Selected Grate Inlets on Continuous Grades." V. 2, *FHWA-RD-78-4*. Washington, D.C.

Psomas and Associates (1991). *El Dorado County Drainage Manual (Draft)*. Sacramento, CA.

Water Environment Federation / American Society of Civil Engineers (1992). *Design and Construction of Urban Stormwater Management Systems*. New York, NY.

*See Appendix 3.1.1 for updated references*

### **Appendix 3.1.1 Updated References**

Listed below is the updated reference for this section. If an updated version was not available, the original version should be referenced.

Federal Highway Administration (2013). "Urban Drainage Design Manual"  
*Hydraulic Engineering Circular No. 22, Third Edition (HEC-22)*.  
Washington, D.C.



*This page intentionally left blank.*

**Section  
4**

**Hydraulic Design of Closed Conduits**

This section discusses the principles to be used for the design and analysis of closed conduit drainage systems in El Dorado County. This type of system is generally used for higher density developments or when it is desired to maximize useable land area.

**Contents of this section**

- 4.1 Background..... 4-2
- 4.2 Analysis Procedures ..... 4-3
  - 4.2.1 Classification of Closed Conduit Flow ..... 4-3
  - 4.2.2 Manning’s Equation ..... 4-3
  - 4.2.3 Selection of Manning’s n Value ..... 4-4
  - 4.2.4 Uniform Flow in Circular Pipes ..... 4-5
  - 4.2.5 Critical Depth in Circular Pipes ..... 4-5
  - 4.2.6 Non-uniform Flow in Circular Pipes ..... 4-6
  - 4.2.7 Pressure Flow Calculations ..... 4-9
  - 4.2.8 Evaluation of Minor Losses..... 4-9
- 4.3 Closed Conduit Design Criteria..... 4-9
  - 4.3.1 Alignment..... 4-9
  - 4.3.2 Hydraulic Grade Line ..... 4-10
  - 4.3.3 Easements..... 4-10
  - 4.3.4 Design Flow..... 4-10
  - 4.3.5 Velocity Requirements..... 4-10
  - 4.3.6 Pipe Size ..... 4-10
  - 4.3.7 Manholes ..... 4-10
  - 4.3.8 Inlet Structures ..... 4-11
  - 4.3.9 Outlet Structures..... 4-11
  - 4.3.10 Fencing and Protection Barriers ..... 4-11
  - 4.3.11 Debris Racks ..... 4-12
  - 4.3.12 Flap Gates ..... 4-12
  - 4.3.13 Placement and Construction..... 4-12
  - 4.3.14 Subdrainage ..... 4-12
  
- Appendix 4.1 References..... 4-13
  - Appendix 4.1.1 Updated References..... 4-14
- Appendix 4.2 Hydraulic Properties for Circular Conduits..... 4-15
- Appendix 4.3 Evaluation of Minor Losses in Pipes ..... 4-19

#### **4.1 Background**

Once the appropriate level of protection is defined, the design discharge is computed according to the procedures in Section 2, and the inlet capacities are determined according to the procedures in Section 3, a closed conduit drainage system of appropriate size and configuration can be designed. The closed conduit drainage system is designed to convey all runoff from the 10-year event. In conjunction with street flow, it will also protect adjacent areas from events that do not exceed the 100-year event. In the design of closed conduit systems, the engineer should evaluate the consequences of events larger than the specified design events. Estimating the damage caused by a 500-year flood event with the proposed improvements in place, and then verifying that the damage would not be worse than the no-improvement condition is an example of such an evaluation.

Extensive information is available on both the theoretical and practical design of closed conduit drainage systems. Simplifying assumptions are often made in the analysis of such systems. Also standardized design and construction methods are often employed. El Dorado County expects that the engineer will have substantial familiarity with the analysis and design of closed conduit drainage systems. Furthermore, the engineer should be aware of how simplified analyses, conservative assumptions, and standard construction practice affects the overall performance of the drainage system for events between the 10-year and 100-year recurrence interval. An example of this would be the following: all the inlets at the upstream end of a development are intentionally oversized to account for potential debris blockage. The closed conduit system is designed to convey the 10-year event. The engineer then analyzes what would happen if the closed conduit system receives inflow greater than the 10-year event and converts to a pressure flow situation.

In general El Dorado County expects the engineer to assess the overall performance of the drainage system. The purpose of this section is to cover the primary design issues, analysis procedures, and design criteria for closed conduit drainage systems. In many cases, the engineer will have to refer to the referenced source material to adequately investigate the details of a particular design. El Dorado County has adopted a closed conduit design criterion that is substantially based on the following standard reference: *ASCE Manuals and Reports of Engineering Practice No. 77 (Manual of Practice No. 77) / WEF Manual of Practice FD-20: Design and Construction of Urban Stormwater Management Systems*, Chapters 6 and 8.

## **4.2 Analysis Procedures**

This section discusses analysis procedures appropriate for the hydraulic design of closed conduit drainage systems. The types of computations discussed in this section do not require the use of computer programs. Computer programs, especially spreadsheet approaches, may increase speed, accuracy, and clarity of computations.

### **4.2.1 Classification of Closed Conduit Flow**

For the design of closed conduit systems, steady flow at the peak discharge is typically assumed. If the conduit is long, has constant diameter, and has no backwater effects from downstream controls, the flow can be considered uniform and analyzed as such.

For steady, uniform conditions, water will flow at its normal depth. Normal depth occurs when the work done by gravity to move water is in equilibrium with the energy loss due to channel boundary roughness. Manning's equation computes the normal depth of flow for a given discharge.

For steep slopes, normal depth is usually in the supercritical regime. This is when inertial forces are greater than gravitational forces. For flatter slopes, velocities are slower and gravitational forces dominate, thus normal depth is usually in the subcritical regime. Closed conduit systems should be designed to maintain flow depths entirely in either the subcritical or supercritical range. This will avoid the occurrence of internal hydraulic jumps.

### **4.2.2 Manning's Equation**

As discussed above, Manning's equation gives the normal depth for a given discharge assuming steady, uniform flow conditions:

$$Q = \frac{1.49}{n} AR^{2/3} S_f^{1/2} \quad (\text{Eq. 4.2.1})$$

in which, Q = discharge in ft<sup>3</sup>/sec; n = Manning's roughness coefficient; A = cross sectional area of flow in ft<sup>2</sup>; R is the hydraulic radius (area divided by wetted perimeter) in ft; S<sub>f</sub> is the slope of the energy grade line in ft/ft.

For a circular pipe flowing full, Manning's equation can be rewritten as:

$$Q = \frac{0.463 D^{8/3} S_f^{1/2}}{n} \quad (\text{Eq. 4.2.2})$$

in which, D = pipe diameter in ft. This form of the equation is useful for determining the design pipe size.

Analysis circular pipes flowing partially full can be accomplished by rearranging Equation 4.2.2 as shown:

$$\frac{Qn}{D^{8/3} S_f^{1/2}} = \text{Constant} \quad (\text{Eq. 4.2.3})$$

The value of the constant in Equation 4.2.3 is 0.463 when the pipe is flowing full. When the pipe is flowing partially full, the flow depth y is less than the pipe diameter D. Appendix 4.2 gives the value of this constant for the entire range of y/D.

### 4.2.3 Selection of Manning's n Value

Pipe manufacturers often provide information on acceptable design values for Manning's n. These shall be used when they agree with generally accepted values. An example where a manufacturer's n value should not be used is corrugated metal pipe that is intended to create helicoidal flow. The manufacturer's n-value is typically based on a condition with no sediment or debris present in the system. If sediment deposits are present, the helicoidal flow pattern is disrupted and the flow behaves similar to traditional corrugated pipe. Table 4.2.1 gives recommended ranges of Manning's n value for pipe materials that are commonly used in El Dorado County.

**Table 4.2.1 Typical Manning's n Values for Closed Conduits**  
(Source: WEF/ASCE, 1992)

| Description  | Manning's n |
|--|-------------|
| Reinforced Concrete Pipe                               | 0.013       |
| Corrugated Metal Pipe<br>(1/2" by 2-1/2" Corrugations) | 0.024       |
| Smooth Plastic Pipe                                    | 0.013       |
| Formed Concrete (Smooth)                               | 0.013       |
| Formed Concrete (Rough)                                | 0.016       |

#### 4.2.4 Uniform Flow in Circular Pipes

For uniform flow, the energy grade line is parallel to the invert profile, thus  $S_f = S_0$ , the slope of the pipe. Manning's equation can therefore be used to compute the normal flow depth, given the pipe diameter, the bed slope, and the  $n$  value. The computation of normal depth using a given discharge for a pipe is usually done by graphical means or with dimensionless tables. Appendix 4.2 lists the dimensionless hydraulic quantities for a circular pipe flowing partially full.

As an example, determine the flow depth and velocity for a 60" diameter concrete pipe carrying 300 cfs at a slope of 2.5%: From Table 4.2.1, the Manning's  $n$  value is 0.013. Uniform flow is assumed therefore,  $S_f = 0.025$ . Using Equation 4.2.3:

$$\frac{(300)(0.013)}{(60/12)^{8/3}0.025^{1/2}} = 0.337$$

The value 0.337 is located under column 3 of the table in Appendix 4.2. This corresponds to a value of  $y/D = 0.633$ . Therefore the flow depth  $y$  is equal to 3.17 feet.

The average velocity of flow is determined by dividing the design discharge by the cross sectional flow area. Column 2 of the appropriate row in Appendix 4.2 gives a ratio  $A/D^2$  equal to 0.524. The flow area  $A$  is determined as follows:

$$A = (0.524)(60/12)^2 = 13.10 \text{ ft}^2$$

The mean flow velocity is thus  $300/13.10 = 22.90 \text{ ft/sec}$ .

#### 4.2.5 Critical Depth in Circular Pipes

For circular pipes, Brater and King (1976<sup>11</sup>) indicate that:

$$K_c' = \frac{Q}{D^{5/2}} \quad (\text{Eq. 4.2.4})$$

in which  $K_c'$  is a constant shown in column 4 of the table in Appendix 4.2.

---

<sup>11</sup> This publication by Brater and King, *Handbook of Hydraulics*, 6<sup>th</sup> edition, now has an 8<sup>th</sup> edition (2017). See Appendix 4.1.1 for updated references.

Consider the same example as in the previous section. Determine the critical depth for a 60" diameter concrete pipe carrying 300 cfs: Using equation 4.2.4:

$$\frac{(300)}{(60/12)^{5/2}} = 5.367$$

The value of 5.367 is located under column 4 of the table in Appendix 4.2. This corresponds to a value of  $y/D = 0.933$ . Therefore the critical flow depth for this situation is 4.67 feet.

#### **4.2.6 Non-uniform Flow in Circular Pipes**

Non-uniform flow occurs when either an upstream or a downstream condition causes the flow depth at a given point to be different from normal depth. These conditions can include: a change in pipe slope, a change in roughness, a transition, a pipe junction, backwater from a receiving stream, or an in-line structure such as a catch basin or manhole. For non-uniform flow conditions, the flow depth can be computed from the known flow depth at an adjacent cross section using the steady state, gradually varied flow equation:

$$\frac{\Delta y}{L} = \frac{S_0 - S_f}{1 - F^2} \quad (\text{Eq. 4.2.5})$$

in which  $L$  = the distance between the control section and the unknown section in feet;  $S_0$  = the bed slope in ft/ft;  $S_f$  = the slope of the energy grade line in ft/ft;  $F$  = the Froude number.

The purpose of non-uniform flow computations for pipes is to determine the flow behavior between a control point and the establishment of uniform flow. Prior to performing non-uniform flow calculations, it is important to know the relative shape of the water surface profile. Under most circumstances the gradually varied water surfaces fall under one of the following classifications:

**M-1** For this case, the pipe has a mild slope and the flow depth is greater than normal depth. This category of flow often occurs when a pipe enters a deep body of water such as a pond or a large channel.

**M-2** For this case, the pipe has a mild slope and the flow depth is between sub-critical normal depth and critical depth. This category of flow often occurs upstream of an abrupt slope increase and the water surface approaches critical depth as it nears the slope change.

**S-2** For this case, the pipe has a steep slope and flow depth is between critical depth and super-critical normal depth. This category of flow often occurs downstream of an abrupt increase in slope causing the water surface to fall below critical depth into the super-critical regime.

If the water surface is identified as S-2, the flow regime should remain supercritical throughout the system to avoid hydraulic jumps at the transition between steep and mild slopes.

*Example*

An example is presented here that demonstrates the use of gradually varied flow calculations of circular closed conduits. Flow enters a street inlet at a rate of 40 cfs. It then travels through a 36" pipe that is placed on a slope of 0.02 ft/ft and has a Manning's n value of 0.013. The pipe extends 240 feet where it ends at a large manhole structure. Determine the flow characteristics in the pipe.

*Solution*

First the critical and normal depth for the pipe is computed as discussed in Sections 4.2.4 and 4.2.5. For normal depth, the quantity  $Qn/D^{8/3}S_f^{1/2} = 0.1964$ . From Appendix 4.2, this corresponds to a value  $y/D = 0.454$ . Thus normal depth is 1.36 feet. For critical depth, the quantity  $Q/D^{5/2} = 2.566$ . From Appendix 4.2, this corresponds to a value  $y/D = 0.686$ . Thus critical depth is 2.06 feet.

Since normal depth is less than critical depth, it is clear that the water surface profile can be classified as S-2. Therefore computations will start at critical depth (2.06 feet) and proceed in the downstream direction until the end of the pipe is reached. The computation steps and results are explained in Table 4.2.2.

Note that downstream of station 0+60, the flow in the pipe is very close to normal depth. When the computed flow depth is reasonably close to normal depth, additional non-uniform flow computations are not necessary.



**Table 4.2.2 Example Calculation of Non-uniform Flow Computation in a Closed Conduit for S-2 Drawdown.**  
 (Source: WEF/ASCE, 1992)

| Station<br>(1) | L<br>(ft)<br>(2) | Q<br>(cfs)<br>(3) | $\frac{Q_n}{D^{3/2}}$<br>(4) | Water Surf. Elev.<br>(ft)<br>(5) | Invert Elev.<br>(ft)<br>(6) | y<br>(ft)<br>(7) | y/D<br>(8) | A/D <sup>2</sup><br>(9) | A<br>(ft <sup>2</sup> )<br>(10) | V<br>(ft/s)<br>(11) | V <sup>2</sup> /2g<br>(12) | Assumed Energy Grade Line Elev.<br>(ft)<br>(13) | $\frac{Q_n}{D^{3/2}S^{3/2}}$<br>(14) | S <sub>i</sub><br>(15) | Average S <sub>i</sub><br>(16) | Head Loss<br>(ft)<br>(17) | Computed Energy Grade Line Elevation<br>(ft)<br>(18) | Comments     |
|----------------|------------------|-------------------|------------------------------|----------------------------------|-----------------------------|------------------|------------|-------------------------|---------------------------------|---------------------|----------------------------|---|--------------------------------------|------------------------|--------------------------------|---------------------------|--|--------------|
| 0+00           |                  | 40                | 0.0278                       | 102.06                           | 100.00                      | 2.06             | 0.687      | 0.5760                  | 5.184                           | 7.72                | 0.925                      | 102.98  | 0.378                                | 0.0054                 |                                |                           | 102.98   | Street Inlet |
| 0+10           | 10               | 40                | 0.0278                       | 101.54                           | 99.80                       | 1.74             | 0.580      | 0.4724                  | 4.251                           | 9.41                | 1.375                      | 102.91  | 0.295                                | 0.0089                 | 0.0071                         | 0.07                      | 102.91   |              |
| 0+60           | 50               | 40                | 0.0278                       | 100.33                           | 98.80                       | 1.52             | 0.507      | 0.3927                  | 3.534                           | 11.32               | 1.989                      | 102.32  | 0.232                                | 0.0143                 | 0.0116                         | 0.58                      | 102.33   |              |
| 1+50           | 90               | 40                | 0.0278                       | 98.38                            | 97.00                       | 1.38             | 0.460      | 0.3527                  | 3.174                           | 12.60               | 2.466                      | 100.85  | 0.201                                | 0.0191                 | 0.0167                         | 1.50                      | 100.83   |              |
| 2+40           | 90               | 40                | 0.0278                       | 96.57                            | 95.20                       | 1.37             | 0.457      | 0.3490                  | 3.141                           | 12.74               | 2.518                      | 99.09   | 0.198                                | 0.0197                 | 0.0194                         | 1.74                      | 99.08  | Manhole      |

**Explanation:**

- Column 1: Station in feet.
- Column 2: First line, leave blank. Remaining lines, enter distance from this station to the previous station.
- Column 3: Discharge in cfs.
- Column 4: Useful constant for calculations.
- Column 5: First line, enter known control water surface elevation. Remaining lines enter assumed water surface elevation based on the profile classification M-1, M-2, or S-1.
- Column 6: Elevation of invert based on slope of pipe.
- Column 7: Depth of flow = (5)-(6).
- Column 8: Dimensionless flow depth = (7)/Pipe Diameter in feet.
- Column 9: Dimensionless value from column 2 in the table in Appendix 4.2.
- Column 10: Cross sectional area = (9) x (Pipe Diameter)<sup>2</sup>
- Column 11: Mean flow velocity = (3) / (10)
- Column 12: Velocity Head computed using (11)
- Column 13: Assumed value of the energy grade line elevation = (5) + (12)
- Column 14: Value from column 3 of Appendix 4.2 corresponding to y/D
- Column 15: Local energy grade line slope = {(4)/(14)}<sup>2</sup>
- Column 16: First line, no entry. Remaining lines, enter average value of S<sub>i</sub> for the reach.
- Column 17: First line, no entry. Remaining lines, head loss = (2) x (16).
- Column 18: First line, enter known energy grade line elevation. Remaining lines, enter the value of the energy grade line at the preceding station minus the computed head loss (17). Column (18) should be in approximate agreement with column (13) before continuing with the calculations. If it is not, adjust the assumed water surface elevation, column (5), and go through the procedure again.

### ***4.2.7 Pressure Flow Calculations***

Pressure flow occurs when the normal flow depth exceeds the diameter of the pipe. The governing equations for such conditions can be found in any standard text on pipeline hydraulics. Closed conduit storm drain trunk lines systems in El Dorado County are typically designed to function under non-pressurized flow. Except for special cases, such as detention basin outlet works, pressure flow analysis is not addressed in this manual.

### ***4.2.8 Evaluation of Minor Losses***

The previous discussions addressed frictional energy loss due to pipe roughness. Underground closed conduit systems have features such as transitions, junctions, bends, entrances, exits, etc., which result in localized energy losses that are usually represented by a steep slope or sudden drop in the energy grade line. Such energy losses are termed minor losses. They can, however, exceed frictional energy losses under certain conditions.

Minor losses can be evaluated directly (See Appendix 4.3) or by using an effective Manning's  $n$  value which incorporates losses due to both friction and minor losses.

## **4.3 Closed Conduit Design Criteria**

This section discusses specific design criteria that apply to various elements of design. The goal of such criteria is to guide the engineer in designing an adequate facility that will provide reliable flood protection and meet the environmental objectives of El Dorado. After following the analysis procedures and design criteria in this section, the engineer should evaluate the overall soundness and function of the design. If deviations from these criteria are necessary, they should be documented and presented to El Dorado County in the design report.

### ***4.3.1 Alignment***

The alignment of closed conduit systems usually follows the street patterns. Smaller radius curves create larger energy losses. For vertical curves where the slope is decreasing, the primary concern is the development of a hydraulic jump. The potential for this should be addressed in the design.

### **4.3.2 Hydraulic Grade Line**

Closed conduit drainage systems are designed to function as circular pipes flowing partially full at the 10-year discharge except in a detention facility. For this condition, the hydraulic grade line should be below the ceiling of the pipe. The energy grade line should be at least 0.5 feet below all manhole lids and grate inlets. Both the hydraulic grade line and the energy grade line should be shown on the plans. If the closed conduit system could allow the entry of flows that exceed the design discharge, the impact of this should be considered on downstream inlets and manholes.

### **4.3.3 Easements**

Closed conduits are typically placed within the street alignment. When closed conduits cross private property, such as parking lots or residential lots, a drainage easement is necessary.

### **4.3.4 Design Flow**

The design flow for closed conduit systems is defined in Section 4.2.2. Although reference is made to specific event frequencies in this section, Section 1 is the definitive statement of design flows.

### **4.3.5 Velocity Requirements**

In general, design mean flow velocities in closed conduit systems will range from 2 feet per second to 25 feet per second. When it is possible for sediment or debris to enter the system, the velocity must be high enough to prevent deposition within the pipe.

### **4.3.6 Pipe Size**

The minimum main line pipe size is 18 inch diameter. For short laterals and inlet connectors, the minimum diameter is 12 inches.

### **4.3.7 Manholes**

#### *Spacing*

The purpose of a manhole is to allow access to the entire closed conduit system for maintenance and repair. Manholes should therefore be located with this as

the primary criterion. In general, on straight reaches, spacing should be at intervals shown in table.

#### *Location*

In addition to the above criteria, manholes should be located where significant reductions in grade occur, where there are numerous bends or complex junctions, or where access to the system is critical. They should be placed to minimize traffic interference.

#### *Pressurized Manholes*

When pressurized manholes are needed they shall be fitted with specifically designed frames and covers.

**Table 4.3.1 Maximum Access Spacing**  
(Source: American Association of State Highway and Transportation Officials, 2014)

| Size of Pipe (in.) | Maximum Distance (ft) |
|--------------------|-----------------------|
| 12–24              | 300                   |
| 27–36              | 400                   |
| 42–54              | 500                   |
| ≥ 60               | 1000                  |

#### **4.3.8 Inlet Structures**

Refer to Sections 3 and 7 for specific details regarding inlet structures.

#### **4.3.9 Outlet Structures**

The outlet of a closed conduit system should be designed to account for any backwater effects of the receiving stream. Appropriate energy dissipation and erosion control must also be provided (Federal Highway Administration, 1983<sup>12</sup>).

#### **4.3.10 Fencing and Protection Barriers**

Closed conduit systems should be planned to exclude public entry. This is an important part of the overall design of the system. Both inlet and outlet facilities may require protection barriers such as racks, fencing, etc. in order to prevent the public from entering the system. Such features must be designed with both safety and hydraulic efficiency in mind.

---

<sup>12</sup> This publication produced by the Federal Highway Administration, *HEC-14*, was updated in 2006. See Appendix 4.1.1 for updated references.

#### **4.3.11 Debris Racks**

Inlet structures that receive runoff from undeveloped areas may require the use of a properly designed debris rack in order to prevent the entry of boulders, tree branches and other debris into the closed conduit system. Such racks must be designed to prevent blockage of the inlet. The engineer should consider the potential effects of blockage on the overall performance of the project, however.

#### **4.3.12 Flap Gates**

When the outlet of a closed conduit system is below the design elevation of the receiving waters, a flap gate may be required in order to prevent backup of flow into the lateral system. Contact El Dorado County for specific information regarding flap gates.

#### **4.3.13 Placement and Construction**

El Dorado County requires the closed conduit system to perform as designed. Issues such as settlement, pipe joints, expansion, and seismic motion should be accounted for in the design and the construction of the system.

#### **4.3.14 Subdrainage**

All structures must be designed and constructed to provide adequate subdrainage.

#### **Appendix 4.1 References**

County of El Dorado (1990). *Design and Improvement Standards Manual*. Placerville, CA.

Federal Highway Administration (1983). "Hydraulic Design of Energy Dissipators for Culverts and Channels." *Hydraulic Engineering Circular No. 14 (HEC-14)*. Washington, D.C.

Psomas and Associates (1991). *El Dorado County Drainage Manual (Draft)*. Sacramento, CA.

Water Environment Federation / American Society of Civil Engineers (1992). *Design and Construction of Urban Stormwater Management Systems (Manual of Practice No. 77)*. New York, NY.

*See Appendix 4.1.1 for updated references*

### **Appendix 4.1.1 Updated References**

Listed below are the updated versions of select references for this section or references that were absent from the original *Drainage Manual*. If an updated version was not available, the original version should be referenced.

American Association of State Highway and Transportation Officials, ed. *AASHTO Drainage Manual 2014. Chapter 13 Storm Drainage Systems, Table 13-1 Access Hole Spacing. Page 13-7*

Federal Highway Administration (1985). "Hydraulic Design of Highway Culverts." *Hydraulic Design Series No. 5 (HDS-5), FHWA-IP-85-15*. Washington, D.C.

Federal Highway Administration (2006). "Hydraulic Design of Energy Dissipators for Culverts and Channels." *Hydraulic Engineering Circular No. 14 (HEC-14)*. Fairfax, VA.

Federal Highway Administration (2012). "Hydraulic Design of Highway Culverts." *Hydraulic Design Series No. 5 (HDS-5), FHWA-HIF-12-026*. Washington, D.C.

King, H. W., Lindell, J.E., and Moore, W.P. (2017). *Handbook of Hydraulics* (8<sup>th</sup> ed.). McGraw-Hill Education.

**Appendix 4.2 Hydraulic Properties for Circular Conduits**  
**(Source: WEF/ASCE, 1992)**

Hydraulic Properties for Circular Conduits  
 Assuming a Constant Value of Manning's n  
 for the Entire Range of Flow Depths.

| $y/D$ | $\frac{A}{D^2}$ | $\frac{Qn}{D^{8/3}S_f^{1/2}}$ | $\frac{Q_c}{D^{5/2}}$ |
|-------|-----------------|-------------------------------|-----------------------|
| (1)   | (2)             | (3)                           | (4)                   |
| 0.01  | 0.0013          | 0.00007                       | 0.0006                |
| 0.02  | 0.0037          | 0.00031                       | 0.0025                |
| 0.03  | 0.0069          | 0.00074                       | 0.0055                |
| 0.04  | 0.0105          | 0.00138                       | 0.0098                |
| 0.05  | 0.0147          | 0.00222                       | 0.0153                |
| 0.06  | 0.0192          | 0.00328                       | 0.0220                |
| 0.07  | 0.0242          | 0.00455                       | 0.0298                |
| 0.08  | 0.0294          | 0.00604                       | 0.0389                |
| 0.09  | 0.0350          | 0.00775                       | 0.0491                |
| 0.10  | 0.0409          | 0.00967                       | 0.0605                |
| 0.11  | 0.0470          | 0.01181                       | 0.0731                |
| 0.12  | 0.0534          | 0.01417                       | 0.0868                |
| 0.13  | 0.0600          | 0.01674                       | 0.1016                |
| 0.14  | 0.0668          | 0.01952                       | 0.1176                |
| 0.15  | 0.0739          | 0.0225                        | 0.1347                |
| 0.16  | 0.0811          | 0.0257                        | 0.1530                |
| 0.17  | 0.0885          | 0.0291                        | 0.1724                |
| 0.18  | 0.0961          | 0.0327                        | 0.1928                |
| 0.19  | 0.1039          | 0.0365                        | 0.2144                |
| 0.20  | 0.1118          | 0.0406                        | 0.2371                |
| 0.21  | 0.1119          | 0.0448                        | 0.2609                |
| 0.22  | 0.1281          | 0.0492                        | 0.2857                |
| 0.23  | 0.1365          | 0.0537                        | 0.3116                |
| 0.24  | 0.1449          | 0.0585                        | 0.3386                |



Hydraulic Properties for Circular Conduits  
Assuming a Constant Value of Manning's n  
for the Entire Range of Flow Depths. (Cont.)

| $y/D$<br>(1) | $A$<br>$D^2$<br>(2) | $Qn$<br>$D^{8/3}S_f^{1/2}$<br>(3) | $Q_c$<br>$D^{5/2}$<br>(4) |
|--------------|---------------------|-----------------------------------|---------------------------|
| 0.25         | 0.1535              | 0.0634                            | 0.3667                    |
| 0.26         | 0.1623              | 0.0686                            | 0.3957                    |
| 0.27         | 0.1711              | 0.0739                            | 0.4259                    |
| 0.28         | 0.1800              | 0.0793                            | 0.4571                    |
| 0.29         | 0.1890              | 0.0849                            | 0.4893                    |
| 0.30         | 0.1982              | 0.0907                            | 0.5226                    |
| 0.31         | 0.2074              | 0.0966                            | 0.5969                    |
| 0.32         | 0.2167              | 0.1027                            | 0.5921                    |
| 0.33         | 0.2260              | 0.1089                            | 0.6284                    |
| 0.34         | 0.2355              | 0.1153                            | 0.6657                    |
| 0.35         | 0.2450              | 0.1218                            | 0.7040                    |
| 0.36         | 0.2546              | 0.1284                            | 0.7433                    |
| 0.37         | 0.2642              | 0.1351                            | 0.7836                    |
| 0.38         | 0.2739              | 0.1420                            | 0.8249                    |
| 0.39         | 0.2836              | 0.1490                            | 0.8672                    |
| 0.40         | 0.2934              | 0.1561                            | 0.9104                    |
| 0.41         | 0.3032              | 0.1633                            | 0.9546                    |
| 0.42         | 0.3130              | 0.1705                            | 0.9997                    |
| 0.43         | 0.3229              | 0.1779                            | 1.0459                    |
| 0.44         | 0.3328              | 0.1854                            | 1.0929                    |
| 0.45         | 0.3428              | 0.1929                            | 1.1410                    |
| 0.46         | 0.3527              | 0.2010                            | 1.1900                    |
| 0.47         | 0.3627              | 0.2080                            | 1.2400                    |
| 0.48         | 0.3727              | 0.2160                            | 1.2908                    |
| 0.49         | 0.3827              | 0.2240                            | 1.3427                    |

Hydraulic Properties for Circular Conduits  
Assuming a Constant Value of Manning's n  
for the Entire Range of Flow Depths. (Cont.)

| $y/D$<br>(1) | $A$<br>$D^2$<br>(2) | $Qn$<br>$D^{8/3}S_f^{1/2}$<br>(3) | $Q_c$<br>$D^{5/2}$<br>(4) |
|--------------|---------------------|-----------------------------------|---------------------------|
| 0.50         | 0.3927              | 0.232                             | 1.3956                    |
| 0.51         | 0.4027              | 0.239                             | 1.4494                    |
| 0.52         | 0.4127              | 0.247                             | 1.5041                    |
| 0.53         | 0.4227              | 0.255                             | 1.5598                    |
| 0.54         | 0.4327              | 0.263                             | 1.6166                    |
| 0.55         | 0.4426              | 0.271                             | 1.6741                    |
| 0.56         | 0.4526              | 0.279                             | 1.7328                    |
| 0.57         | 0.4625              | 0.287                             | 1.7924                    |
| 0.58         | 0.4724              | 0.295                             | 1.8531                    |
| 0.59         | 0.4822              | 0.303                             | 1.9147                    |
| 0.60         | 0.4920              | 0.311                             | 1.9773                    |
| 0.61         | 0.5018              | 0.319                             | 2.0410                    |
| 0.62         | 0.5115              | 0.327                             | 2.1058                    |
| 0.63         | 0.5212              | 0.335                             | 2.1717                    |
| 0.64         | 0.5308              | 0.343                             | 2.2886                    |
| 0.65         | 0.5404              | 0.350                             | 2.3068                    |
| 0.66         | 0.5499              | 0.358                             | 2.3760                    |
| 0.67         | 0.5594              | 0.366                             | 2.4465                    |
| 0.68         | 0.5687              | 0.373                             | 2.5182                    |
| 0.69         | 0.5780              | 0.380                             | 2.5912                    |
| 0.70         | 0.5872              | 0.388                             | 2.6656                    |
| 0.71         | 0.5964              | 0.395                             | 2.7416                    |
| 0.72         | 0.6054              | 0.402                             | 2.8188                    |
| 0.73         | 0.6143              | 0.409                             | 2.8977                    |
| 0.74         | 0.6231              | 0.416                             | 2.9783                    |

Hydraulic Properties for Circular Conduits  
Assuming a Constant Value of Manning's n  
for the Entire Range of Flow Depths. (Cont.)

| $y/D$<br>(1) | $A$<br>$D^2$<br>(2) | $Q_n$<br>$D^{8/3}S^{1/2}$<br>(3) | $Q_c$<br>$D^{5/2}$<br>(4) |
|--------------|---------------------|----------------------------------|---------------------------|
| 0.75         | 0.6319              | 0.422                            | 3.0606                    |
| 0.76         | 0.6405              | 0.429                            | 3.1450                    |
| 0.77         | 0.6489              | 0.435                            | 3.2314                    |
| 0.78         | 0.6573              | 0.441                            | 3.3200                    |
| 0.79         | 0.6655              | 0.447                            | 3.4111                    |
| 0.80         | 0.6736              | 0.453                            | 3.5051                    |
| 0.81         | 0.6815              | 0.458                            | 3.6020                    |
| 0.82         | 0.6893              | 0.463                            | 3.7021                    |
| 0.83         | 0.6969              | 0.468                            | 3.8062                    |
| 0.84         | 0.7043              | 0.473                            | 3.9144                    |
| 0.85         | 0.7115              | 0.477                            | 4.0276                    |
| 0.86         | 0.7186              | 0.481                            | 4.1466                    |
| 0.87         | 0.7254              | 0.485                            | 4.2722                    |
| 0.88         | 0.7320              | 0.488                            | 4.4057                    |
| 0.89         | 0.7384              | 0.491                            | 4.5486                    |
| 0.90         | 0.7445              | 0.494                            | 4.7033                    |
| 0.91         | 0.7504              | 0.496                            | 4.8724                    |
| 0.92         | 0.7560              | 0.497                            | 5.0602                    |
| 0.93         | 0.7612              | 0.498                            | 5.2727                    |
| 0.94         | 0.7662              | 0.498                            | 5.5182                    |
| 0.95         | 0.7707              | 0.498                            | 5.8119                    |
| 0.96         | 0.7749              | 0.496                            | 6.1785                    |
| 0.97         | 0.7785              | 0.494                            | 6.6695                    |
| 0.98         | 0.7817              | 0.489                            | 7.4063                    |
| 0.99         | 0.7841              | 0.483                            | 8.8261                    |
| 1.00         | 0.7854              | 0.463                            | --                        |

### **Appendix 4.3 Evaluation of Minor Losses in Pipes**

Underground closed conduit systems have features such as transitions, junctions, bends, entrances, exits, etc. which result in localized energy losses that are usually represented by a steep slope or sudden drop in the energy grade line. Such energy losses are termed minor losses. They can, however, exceed frictional energy losses under certain conditions.

- **Transition Losses**

A transition occurs when a pipe changes size. The change in pipe cross sectional area results in a change in velocity which means there is an energy loss.

For a contraction:

$$H_c = K_c \left( \frac{V_2^2}{2g} - \frac{V_1^2}{2g} \right) \dots \text{when } V_2 > V_1 \quad (\text{Eq. 4.2.6})$$

For an expansion:

$$H_e = K_e \left( \frac{V_1^2}{2g} - \frac{V_2^2}{2g} \right) \dots \text{when } V_1 > V_2 \quad (\text{Eq. 4.2.7})$$

in which,  $H_e$  = energy loss due to expansion;  $K_e$  = expansion loss coefficient;  $H_c$  = energy loss due to contraction;  $K_c$  = contraction loss coefficient;  $V_1$  = mean velocity upstream of the transition,  $V_2$  = mean velocity downstream of the transition. When water enters a pipe from a reservoir condition, the contraction equation should be used with  $V_1 = 0$ . Table 4.2.3 lists typical expansion and contraction coefficients.

**Table 4.2.3 Expansion and Contraction Coefficients  
for Closed Conduit Flow  
(Source: WEF/ASCE, 1992)**

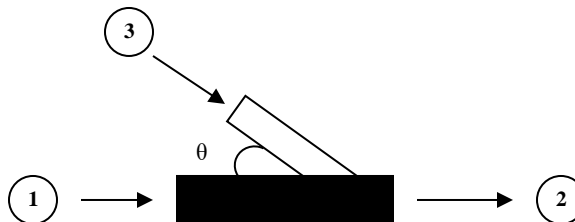
|  |                |
|--|----------------|
| Contraction from Diameter D <sub>1</sub> to D <sub>2</sub> .<br>Ratio of D <sub>2</sub> /D <sub>1</sub>                                    | K <sub>c</sub> |
| 0.0  | 0.5            |
| 0.4  | 0.4            |
| 0.6  | 0.3            |
| 0.8  | 0.1            |
| 1.0  | 0.0            |
| Contraction from<br>Reservoir into a Pipe  | K <sub>c</sub> |
| Square Edge  | 0.5            |
| Bell Mouth   | 0.4            |
| Groove End   | 0.2            |
| Expansion through a<br>Tapering Section.<br>θ below is the Included<br>Angle in Degrees<br>between the<br>Sides of the Tapering<br>Section | K <sub>e</sub> |
| 10   | 0.17           |
| 20   | 0.40           |
| 45   | 1.06           |
| 60   | 1.21           |
| 90   | 1.14           |
| 120  | 1.07           |
| 180  | 1.00           |

- **Manholes and Junctions**

For a straight through manhole junction box where there is no change in pipe size, the minor loss can be estimated by:

$$H_m = 0.05 \frac{V^2}{2g} \quad (\text{Eq. 4.2.8})$$

in which H<sub>m</sub> is the energy loss due to the manhole junction box.



**Figure 4.2.1 Schematic Diagram of Pipe Junction**

Figure 4.2.1 shows a schematic diagram of a pipe junction. For a junction with box with a lateral inflow pipe under full flow conditions, the energy loss is computed from the equation:

$$H_j = y' + \left( \frac{V_1^2}{2g} - \frac{V_2^2}{2g} \right) \quad (\text{Eq. 4.2.9})$$

in which  $H_j$  = the energy loss at a junction;  $V_1$  = mean velocity in the main line upstream of the junction;  $V_2$  = mean velocity in the main line downstream of the junction;  $y'$  is defined below:

$$y' = \frac{Q_2 V_2 - Q_1 V_1 - Q_3 V_3 \cos(\theta)}{0.5g(A_1 + A_2)} \quad (\text{Eq. 4.2.10})$$

in which the subscripts 1, 2, and 3 refer to hydraulic quantities in the upstream main line, the downstream main line, and the lateral inflow pipe respectively;  $Q$  = the discharge in cfs;  $V$  = velocity in ft/sec;  $A$  is the cross sectional area in ft<sup>2</sup>; and  $\theta$  is the angle between the lateral inflow pipe and the alignment of the main line outlet conduit.

- **Pipe Bends**

The following relationship is used to compute energy loss in pipe bends flowing full:

$$H_b = K_b \frac{V^2}{2g} \quad (\text{Eq. 4.2.11})$$

in which  $H_b$  = energy loss in a bend,  $K_b$  = bend loss coefficient; and  $V$  = mean flow velocity in the pipe. The value of  $K_b$  is shown in Table 4.2.4.

**Table 4.2.4 Bend Loss Coefficients**  
**(Source: Federal Highway Administration, 1985<sup>13</sup>)**

| Bend Radius /<br>Pipe Diameter<br>r/D | Angle of Bend, Degrees |      |      |
|---------------------------------------|------------------------|------|------|
|                                       | 90                     | 45   | 22.5 |
| 1.0                                   | 0.50                   | 0.37 | 0.25 |
| 2.0                                   | 0.30                   | 0.22 | 0.15 |
| 4.0                                   | 0.25                   | 0.19 | 0.12 |
| 6.0                                   | 0.15                   | 0.11 | 0.08 |
| 8.0                                   | 0.15                   | 0.11 | 0.08 |

---

<sup>13</sup> This publication produced by the Federal Highway Administration, *Hydraulic Design Series No. 5 (HDS-5)*, was updated in 2012. See Appendix 4.1.1 for updated references.

**Section  
5**

***Stormwater Storage Design***

Stormwater storage permits control of flood runoff volumes and peaks, thus limiting some adverse impact of changes within a catchment. This section defines the design and construction requirements and provides guidance for planning and analyzing storage facilities.

**Contents of this section**

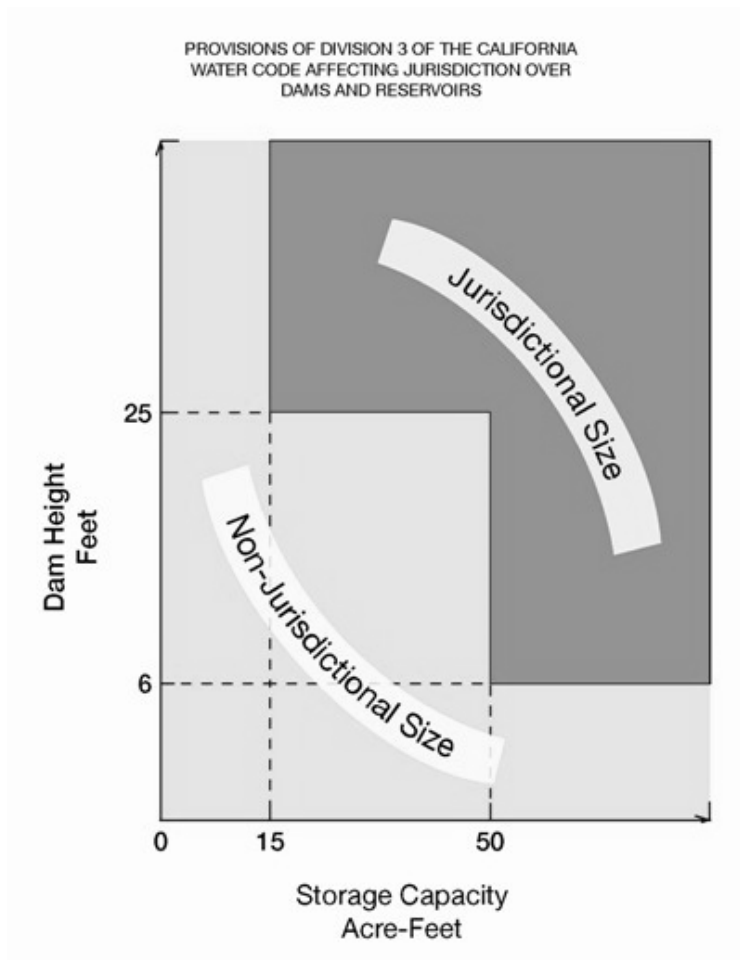
|  |      |
|--|------|
| 5.1 Background.....                                    | 5-2  |
| 5.2 Types of Storage Facilities.....                   | 5-3  |
| 5.2.1 Detention Structures.....                        | 5-4  |
| 5.2.2 Retention Structures.....                        | 5-5  |
| 5.2.3 Special Facilities.....                          | 5-5  |
| 5.2.4 Regional v. On-site Impoundments .....           | 5-6  |
| 5.3 Basin (Pond) Design Requirements.....              | 5-7  |
| 5.4 Embankment Design Requirements .....               | 5-8  |
| 5.5 Spillway Design Requirements .....                 | 5-9  |
| 5.6 Outlet Work Design Requirements.....               | 5-9  |
| 5.6.1 Outlet Types .....                               | 5-9  |
| 5.6.2 Outlet Standards.....                            | 5-10 |
| 5.6.3 Trash Racks .....                                | 5-11 |
| 5.6.4 Outlet Safety.....                               | 5-12 |
| 5.7 Hydrologic and Hydraulic Analysis for Design ..... | 5-12 |
| 5.7.1 Inflow Hydrograph Computations .....             | 5-12 |
| 5.7.2 Outflow Hydrograph Computations.....             | 5-12 |
| 5.7.3 Analysis Steps.....                              | 5-15 |
| Appendix 5.1 References.....                           | 5-16 |
| Appendix 5.1.1 Updated References .....                | 5-17 |



## **5.1 Background**

El Dorado County does not require stormwater storage for all development, but regulates the design and construction of storage if it is provided. This section defines those regulations and describes appropriate analysis procedures.

Depending on the volume of water stored and the height of the stored water, a stormwater storage facility in El Dorado County may be classified as a dam by the California Department of Water Resources, Division of Safety of Dams (DSOD). Fig. 5.1.1 shows the DSOD criteria. Storage facilities in El Dorado County subject to DSOD jurisdiction must be designed and constructed following DSOD guidelines (DSOD, 1977<sup>14</sup>).



**Fig. 5.1.1 Dams within Jurisdiction of DSOD  
(Source: State of California, n.d.)**

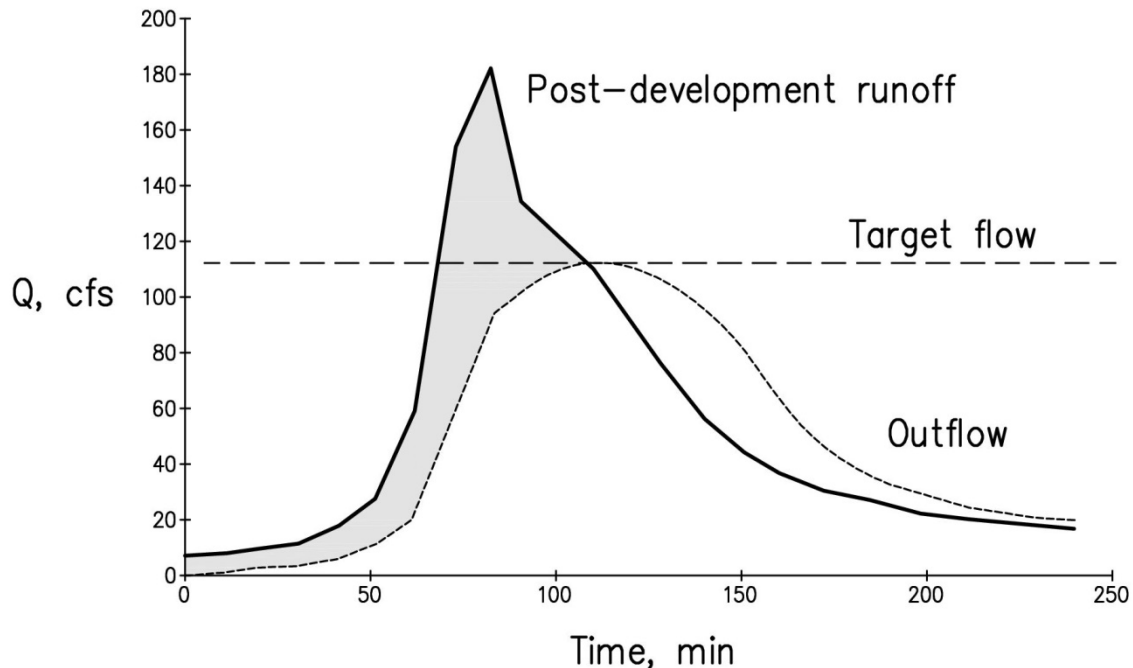
<sup>14</sup> Figure 5.1.1 shows the updated image according to DSOD for the Jurisdictional and Non-Jurisdictional Size of Dams from the California Department of Water Resources' website. See Appendix 5.1.1 for updated references.

If the dam height is more than 6 feet and it impounds 50 acre-feet or more of water, or if the dam is 25 feet or higher and impounds more than 15 acre-feet of water, it will be under our jurisdictional oversight, unless it is exempted

Minor storage facilities (those less than 6 ft in height with capacity less than 15 ac-ft) require only a grading permit, per the requirements of the *Grading Ordinance*.

## **5.2 Types of Storage Facilities**

Stormwater storage facilities mitigate adverse impacts by holding stormwater and releasing it at a rate that will not cause damage downstream. This is illustrated by the hydrographs shown in Fig. 5.2.1.



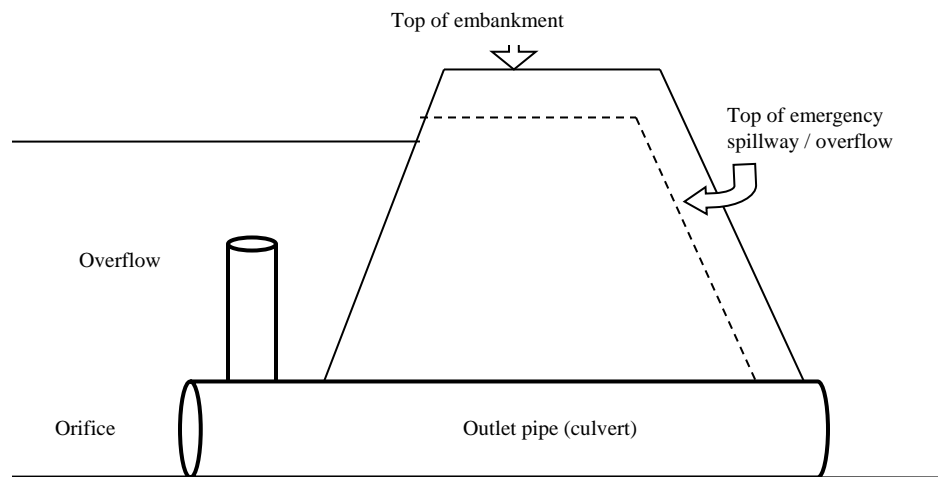
**Fig. 5.2.1 Impact of Storage**

In this figure, the pre-development peak was 113 cfs. After development, the peak increased to 186 cfs. To reduce this peak to the pre-development level, storage was provided. Thus the volume of water represented by the shaded area is stored and released gradually. The total volume of the post-development (inflow) hydrograph and the outflow hydrograph is the same, but the time distribution of the runoff is altered by the stormwater storage facility.

This figure illustrates performance of a detention structure. Retention structures, on the other hand, impound completely the total excess volume and hold it without release. In that case, the stored water infiltrates and evaporates. Other less-frequently used storage facilities include parking lots and underground storage facilities. All are acceptable in El Dorado County, if they are designed and constructed to satisfy appropriate performance and safety requirements.

### 5.2.1 Detention Structures

Fig. 5.2.2 is a simple sketch of a detention structure. The structure stores water temporarily and releases it, either through the outlet pipe or over the emergency spillway. The rate of release depends on the characteristics of the pipe, the characteristics of the inlet to the pipe, and the characteristics of the spillway. Note that the outlet serves two purposes: It limits the release of water during the flood event, and it provides a method of emptying the pond after the event.



**Fig. 5.2.2 Typical Detention Structure**

Detention basins may be classified as:

*Dry basins.* These basins are designed to store water for only a short time during periods of high stormwater runoff. A drainage control structure, usually consisting of a pipe which controls the rate of outflow from the basin, is set in the bottom of the basin, thus providing for complete emptying of the pond when inflow ceases. A sump may be provided below the invert to allow for sediment settling. Fig. 5.2.2 is an example of a dry basin.

*Wet basins.* These basins are designed to maintain a permanent pool of water. The outlets are located above the permanent water surface, so the basin does not drain completely. Wet basins may be used for aesthetic, water quality, or fish and wildlife enhancement. Because of the long-term maintenance requirements necessary to preserve the proper functioning of the wet basin, these facilities are allowed only with specific approval of the County.

### **5.2.2 Retention Structures**

A retention structure stores all or a portion of the inflow for a prolonged time period. These resemble detention basins, yet have no outlet (other than emergency outlets). Outflow is via infiltration or evaporation. In general, the design requirements for a retention structure are consistent with those for a detention structure, unless noted otherwise herein. Retention basins may serve multiple purposes, such as stormwater management and environmental/water quality management. Water quality management structures are typically sized in accordance with MS4 Permit requirements. Such basins have been constructed in the Lake Tahoe Basin.

Retention basins are allowed only with specific approval of the County. As with a wet basin detention facility, a retention basin requires long-term maintenance to insure proper performance. Therefore, any application for such approval will require submittal of an acceptable long-term maintenance plan.

### **5.2.3 Special Facilities**

*Parking lots* may be used to provide additional storage of stormwater runoff from less-frequent, higher-intensity storms when used in conjunction with another storage facility. Parking-lot storage may be used for storms greater than the 10-yr design storm, provided that the following conditions are met:

- The depth of water detained does not exceed 1.0 ft at any location in the parking lot area for the 100-yr design storm; and
- The minimum gradient of the parking lot area subject to ponding is 1%; and
- The emergency overflow path meets the requirements for pond systems; and
- Ponding is restricted to areas that will cause the least inconvenience to parking area users.

Detention for the 10-yr design storm may be permitted with specific approval of the County. The design criteria for a 10-yr storm would be the same as the requirements of a 100-yr storm, as noted above, with the exception of the depth of water stored. The depth of water detained cannot exceed 0.5 feet at any location in the parking lot under the 10-yr design storm.

*Underground storage facilities* may be used to detain temporarily stormwater runoff. For example, tanks and vaults may be used as subsurface detention facilities, with an outlet control structure to control the rate of flow leaving the system. Similarly, a system of perforated pipes may be used to control surface runoff. With such a system, runoff slowly escapes through the perforations and infiltrates in the surrounding soil. Underground storage facilities are appropriate only for small sites, due to the size of facilities required to detain any significant volumes. Therefore, such facilities will be allowed only with specific approval of the County, only for sites of 10 acres or less, and only when other storage alternatives are demonstrated to be inappropriate. Design will be approved on a case-by-case basis.

*Joint-use facilities* serve purposes beyond stormwater-runoff control. For example, a facility may detain flows to reduce damages downstream, while simultaneously retarding flow to permit settlement of particulates. Any design which incorporates secondary uses of the facility must still satisfy all applicable criteria regarding stormwater runoff control. Examples of these types of facilities include, but are not limited to, bio-retention facilities and cisterns.

#### **5.2.4 Regional v. On-site Impoundments**

If storage facilities are planned for an individual site, rather than as a component of an overall regional plan, the storage is referred to as *on-site* detention or *source-control* detention. Such on-site facilities are designed to control short, intense storms that produce the greatest peak flows. The facilities typically are small in scale and are used in El Dorado County when regional detention is not available or if on-site storage is necessary to reduce peak discharge for downstream pipes, culverts, ditches, or streams.

Facilities designed as a component of a watershed planning process are classified as *regional* or *downstream storage* facilities. Generally, a stormwater management plan that incorporates such regional storage can produce more economical and effective mitigation of increase runoff than is possible with numerous small detention basins. Accordingly, regional

drainage plans for specific areas within El Dorado County will evaluate stormwater management requirements for larger catchments. These plans may identify requirements for regional detention facilities, i.e., facilities that are owned and maintained by the County. Such facilities typically are larger than on-site, privately-owned basins, and are designed to control systematically runoff from the total watershed. Detention facilities identified within these regional drainage studies must meet all applicable drainage performance requirements. Any variation from these standards requires prior approval of the County.

Coordinated regional detention facilities that take into account the entire watershed area are preferred within El Dorado County. When a regional drainage study has been conducted and regional basins are designed, the regional basin will always take precedence over local basin design.

### **5.3 Basin (Pond) Design Requirements**

Detention and retention basins (ponds) constructed as a component of a stormwater storage system must satisfy the requirements that follow. Exceptions to these requirements may be considered and granted on a case by case basis. If basins will serve as water quality mitigation, additional requirements may apply.

- The basin must be designed to harmonize with its surroundings, and, where possible, to improve the aesthetic quality of developments.
- The length-to-width ratio of the basin must be at least 2:1. A ratio of 5:1 is preferred. The basin inlet and outlet must be located as far apart (hydraulically) as possible.
- Interior side slopes must be no steeper than 3H:1V. Exterior side slopes must be no steeper than 2H:1V, unless stability with steeper slopes is confirmed by a qualified engineer and design is approved by the County.
- Basin walls may be retaining walls, provided that the design is prepared and certified by a qualified engineer. A fence must be placed along the top of the wall.
- A low-flow channel must be provided from the basin inlet(s) to the basin outlet. This channel must be lined with reinforced concrete, rock, or another form of erosion protection, with specific approval of the County. Minimum acceptable slope of the channel is 1%.
- The basin floor must slope towards the low-flow channel with a minimum slope of 1%, measured perpendicular to the low-flow channel. The slopes must be designed as close to minimum as possible to facilitate sedimentation. Because sediment tends to accumulate around the lowest outlet, the invert elevation of any outlet will be located 0.5 ft above the basin floor to minimize clogging. Care

must be taken to eliminate accumulation of stagnant water within the pond.

- All earthen slopes must be covered with topsoil and re-vegetated as soon as is practical. If the slopes are subject to wave action, additional protection must be provided.
- Safety features to protect the public must be incorporated. Fencing, consisting of 6-ft chain-link meeting Caltrans standards, should be provided around the perimeter of detention basins when appropriate. Access gates constructed of the same material as the fencing must be included, with a minimum opening of 12 ft.
- Maintenance of all storage facilities must be addressed explicitly in the design and construction. Vehicular access for maintenance of the pond and outlet works, removal of sediment, and removal of floating objects during all weather conditions must be provided. This access must be from a public street or from the parcel upon which the basin is constructed. An access road must be provided to the basin floor of all detention facilities. This road must have a minimum width of 12 ft and a maximum grade of 20%. Turn-a-rounds at the control structure and the bottom of the basin must have a 40 ft minimum outside turning radius. A maintenance plan must be developed and provided along with the design documents.
- Basins should be designed to drain within 72 hours in accordance with vector control requirements.

#### **5.4 Embankment Design Requirements**

Detention and retention basins (ponds) constructed as a component of a stormwater storage system must satisfy the requirements that follow. Exceptions to these requirements may be considered and granted on a case by case basis.

- A minimum of 1.5 ft of freeboard must be provided between the top of the embankment and the maximum design water-surface elevation of the spillway (see Section 5.5). To determine this water-surface elevation, assume that the 100-yr storm runoff occurs when the basin is full, compute the corresponding spillway discharge, and determine the maximum water-surface elevation of this spillway flow.
- The maximum embankment depth must be determined by a qualified engineer.
- The embankment must have a minimum 15-ft top width where necessary for maintenance access. Otherwise the top width may vary as recommended by a qualified engineer.
- The toe of the exterior slope of the embankment must be more than 25 ft from the tract or easement property line.

- Embankment design and construction material shall be approved by El Dorado County. Native consolidated soil is preferred.
- All earthen slopes will be covered with topsoil and stabilized with appropriate vegetation, subject to approval of El Dorado County and the NRCS, as soon as is practical after construction.

### **5.5 Spillway Design Requirements**

Regional or larger on-site structures may pose significant hazards to public safety in the event of a failure. Consequently, in addition to any other outlet control structure, an emergency overflow spillway (secondary overflow) must be provided. This spillway must satisfy the requirements that follow. Exceptions to these requirements may be granted by the County for good reason.

- The emergency overflow spillway crest elevation must be greater than the maximum design water-surface elevation of the pond.
- The spillway must be designed to pass the 100-yr design storm event if a runoff event exceeds the design event. The spillway design will be based on peak runoff rates for developed site conditions, assuming that the basin is full to the crest of the spillway prior to the beginning of the design event.
- The spillway must be located so overflow is conveyed safely to the downstream channel.
- The spillway must be protected against erosion and scour. Refer to Section 6 of this manual for design requirements for such protection.

### **5.6 Outlet Work Design Requirements**

#### **5.6.1 Outlet Types**

Outlets are designed for the planned release of water from a detention structure. The outlets may consist of separate conduits of various sizes, or of several inlets to a chamber or manifold that leads to a single outlet pipe or conduit. For example, the detention pond in Fig. 5.2.2 has a multiple-stage outlet structure. The lower outlet functions regardless of the volume of inflow. The capacity computation for that outlet is made with procedures described in Section 7.

The capacity of other outlets is determined with appropriate weir, orifice, or pipe formulas, depending on the design of the outlet. For example, the overflow outlet shown in Fig. 5.2.2 is included as a relief outlet, in case the lower outlet is clogged by debris. This overflow functions only when the



inflow volume is sufficient to raise the water-surface elevation to the level of that outlet. The capacity is determined with the weir equation:

$$Q = CLH^{1.5} \quad (\text{Eq. 5.6.1})$$

in which  $Q$  = flow rate;  $C$  = dimensionless discharge coefficient;  $L$  = effective weir crest length;  $H$  = total energy head on crest, including velocity of approach head. The total outlet is the sum of flow through the orifice and flow through the overflow.

### **5.6.2 Outlet Standards**

Outlet works constructed as a component of a stormwater storage system must satisfy the requirements that follow. Exceptions to these requirements may be considered and granted on a case by case basis.

- A pond overflow system must provide controlled discharge for the 100-yr design event without overtopping the pond embankment and without utilizing the emergency spillway. The design must provide controlled discharge directly into the downstream conveyance system. The principal outlet must be able to drain completely the detention facility within 72 hours of the end of the 100-yr storm by gravity flow through the principal outlet.
- Reinforced concrete pipe should be used for the principle outlet of a detention basin. The minimum acceptable outlet pipe diameter is 12 in. If a riser is used, as illustrated in Fig. 5.2.2, provision must be made to completely drain the pond. In general, the riser pipe diameter must be at least one standard pipe size greater than the barrel pipe diameter. The minimum acceptable riser pipe diameter is 24 in. With prior approval by El Dorado County, corrugated metal pipe may be used for the outlet.
- The formation of vortices can cause significant head loss and reduce the discharge for a given head. Consequently, the potential for vortex formation must be evaluated during design, and anti-vortex devices must be installed if the potential exists.
- Depending on the geometry of the outlet structure (either drop-inlet riser or hood-inlet pipe), discharge for various depths can be controlled by the inlet crest (weir control), or the riser or barrel opening (orifice control), or the riser or barrel pipe (pipe control). Each of these flow controls shall be evaluated when determining the rating curve of the principal outlet.
- Flow-control facilities must be designed for unrestricted flow downstream of the outlet works. Additional storage capacity must be provided if the release rate capability is reduced due to backwater

conditions. In other words, the flow control facilities must be selected on the basis of flow capacity, but the storage volume must be selected on the basis of the actual flow. This guarantees the allowable release rate if downstream restrictions are removed and the backwater condition is eliminated.

- Conduits designed for prolonged pressure flow must be provided with seepage-drainage diaphragms or geotextiles to control erosion of fine material. If the outlets discharge onto easily-eroded materials, stilling basins or other energy-dissipating devices should be provided.
- Outlets must not depend on human intervention to operate gates or other controls during a storm event.
- The number of conduits through the embankment should be minimized.
- Care should be taken to ensure against leaky conduit joints in the embankment.
- Thin-walled conduit should not be used in the embankment without a protective exterior encasement.
- The conduit should be designed to operate with minimum internal water pressure.
- Debris will build up, so the basin and outlet works should be designed accordingly, accounting for the resulting energy loss.

### **5.6.3 Trash Racks**

Outlets for detention ponds in El Dorado County must be protected by trash racks. These are grates, grills, filters, or screens that protect the outlet from plugging with debris. Additional water quality trash capture requirements may apply for certain project types. WEF/ASCE (1992) offers, and El Dorado County endorses, the following guidance for design of racks for detention facilities:

- Trash racks must be large enough that partial plugging will not restrict outflow. As a rule-of-thumb, the trash rack area should be at least ten times larger than the outlet orifice. For very small outlets, an even larger ratio may be necessary to control the initial flush of debris.
- The rack should be sufficiently far from the outlet opening to avoid interference with the hydraulic performance of the outlet.
- Rack openings should be appropriate for the dimensions of the outlet protected: a smaller outlet demands smaller openings. Multiple racks with varied spacing may be used if the outlet consists of multiple openings of various sizes.
- Trash racks must have hinged openings to permit access for removal of accumulated debris and sediment.
- Maintenance access must be provided, as well as a means to drain the pond if the basin is a wet basin.

#### **5.6.4 Outlet Safety**

Outlet works create a potential hazard when operating; a person can be swept into the opening. Accordingly, fencing and trash racks must be provided on both upstream and downstream openings, and public access must be limited. In addition, outlets should be planned and designed to minimize flow velocities.

### **5.7 Hydrologic and Hydraulic Analysis for Design**

#### **5.7.1 Inflow Hydrograph Computations**

Inflow hydrographs for design and analysis of impoundments must be computed with procedures described in Section 2 of this manual. The hydrograph method of Section 2.4 must be used.

The engineer is cautioned here that, even though County regulations stipulate the event for which a structure is to be designed, performance of the structure with larger and smaller events must be reviewed. For example, suppose a structure is designed to reduce the post-development peak due to a 100-yr 24-hr event. As a component of the complete analysis, the engineer should determine also downstream flows due to, for example, the 10-yr 24-hr event. The 10-yr post-development peak will almost certainly be greater than the 10-yr pre-development peak. However, without proper consideration in design of the detention outlet, the structure might not reduce this 10-yr post-development peak. Thus downstream flooding due to this smaller-than-design event will be greater, even though detention is provided. Further, in some cases the detention may delay a flood peak so it coincides in time with peak from another subcatchment downstream. In that case, the detention may actually increase downstream flooding for the design event. The engineer must provide the details of careful, systematic analysis to identify and remedy these potential problems.

Additionally, some projects may be required to confirm post-project runoff does not exceed estimated pre-project flow rate for the 2-year, 24-hour storm to meet water quality requirements.

#### **5.7.2 Outflow Hydrograph Computations**

Outflow from an impoundment that has horizontal water surface can be computed with the so-called level-pool routing model (also known as modified Puls routing model). The model breaks the total analysis time

into equal intervals of duration  $\Delta t$ . It then solves recursively the following one-dimensional approximation of the continuity equation:

$$I_{\text{avg}} - O_{\text{avg}} = \frac{\Delta S}{\Delta t} \quad (\text{Eq. 5.7.1})$$

in which  $I_{\text{avg}}$  = average inflow during time interval;  $O_{\text{avg}}$  = average outflow during time interval;  $\Delta S$  = storage change. With a finite difference approximation, this can be written as:

$$\frac{I_j + I_{j+1}}{2} - \frac{O_j + O_{j+1}}{2} = \frac{S_{j+1} - S_j}{\Delta t} \quad (\text{Eq. 5.7.2})$$

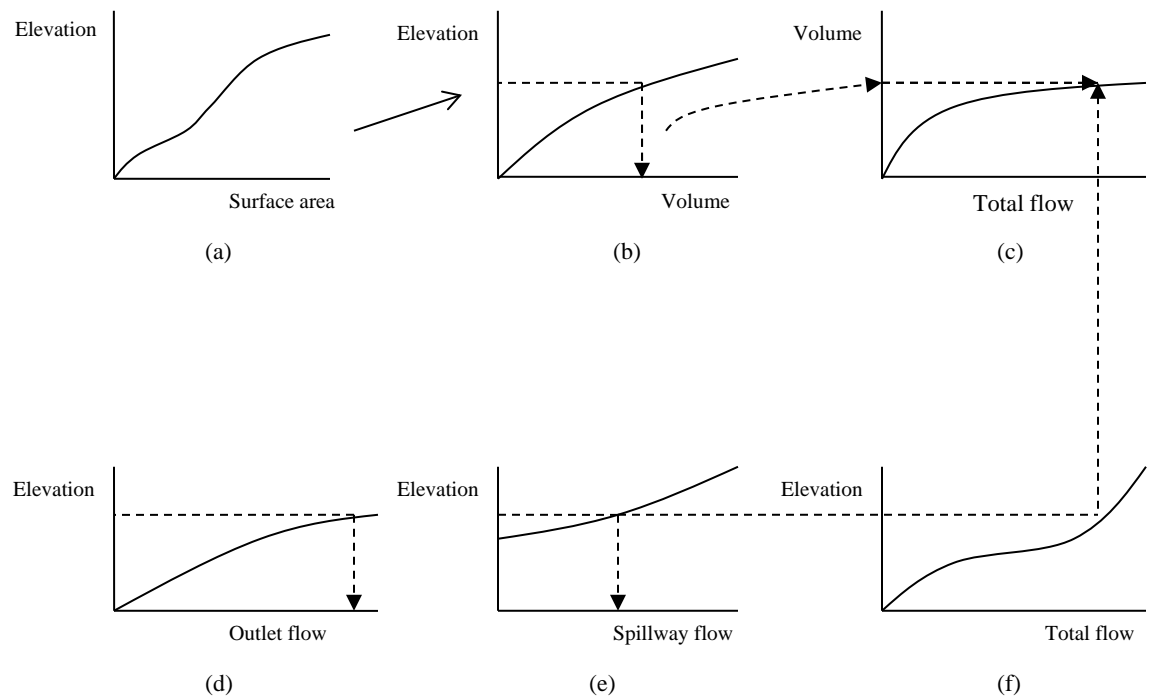
in which  $j$  = index of time interval;  $I_j$  and  $I_{j+1}$  = the inflow values at the beginning and end of the  $j$ -th time interval, respectively;  $O_j$  and  $O_{j+1}$  = the corresponding outflow values; and  $S_j$  and  $S_{j+1}$  = corresponding storage values. Equation 5.7.2 can be rearranged as follows:

$$\left( \frac{2S_{j+1}}{\Delta t} + O_{j+1} \right) = \left( \frac{2S_j}{\Delta t} - O_j \right) \quad (\text{Eq. 5.7.3})$$

All terms on the right-hand side of Equation 5.7.3 are known. The values of  $I_j$  and  $I_{j+1}$  are the inflow hydrograph ordinates computed with the procedures in Section 2.4. The values of  $O_j$  and  $S_j$  are known at the  $j$ -th time interval: at  $j = 0$ , these are the initial conditions, and at each subsequent interval, they are known from calculation in the previous interval. Thus, the quantity  $(2S_{j+1} / \Delta t + O_{j+1})$  is known. For an impoundment, storage and outflow are related, and with this storage-outflow relationship, the corresponding values of  $O_{j+1}$  and  $S_{j+1}$  can be found. The computations can be repeated for successive intervals, yielding values  $O_{j+1}, O_{j+2}, \dots, O_{j+n}$ , the required outflow hydrograph ordinates.

The form of the storage-outflow relationship depends on the characteristics of the basin, the outlet, and the spillway. Fig. 5.7.1 illustrates development of such a storage-outflow relationship. Fig. 5.7.1 (a) is the basin surface area  $v.$  water-surface elevation relationship; the datum for the elevation here is arbitrary, but consistent throughout the figure. This relationship can be derived from topographic maps or grading plans. Fig. 5.7.1 (b) is developed from this with solid-geometry principles. Fig. 5.7.1 (c) is the outlet-rating function. An uncontrolled outlet and a culvert perform identically, so this function is derived following culvert-

rating procedures described in Section 7 of this manual. Fig. 5.7.1 (e) is the spillway rating function. In the simplest case, this function can be developed with the weir equation (Equation 5.7.1). For more complex spillways, the engineer must refer to publications of the USACE (1965<sup>15</sup>) and the NRCS (1985<sup>16</sup>) for appropriate rating procedures. Figs. 5.7.1 (d) and (e) are combined to yield (f). Then, for an arbitrarily-selected elevation, the storage volume is found in (b), and the total flow is found in (f). These may be plotted to yield the desired relationship, as shown in (c).



**FIG. 5.7.1 Derivation of Storage-outflow Relationship**

For additional details on storage routing computations, the engineer should refer to a current version of a hydrology text, such as *Applied Hydrology* by Chow, Maidment and Mays (2010).

<sup>15</sup> This publication produced by the USACE, "Hydraulic Design of Spillways" in *Engineering Manual 1110-2-1603*, was updated in 1992. See Appendix 5.1.1 for updated references.

<sup>16</sup> This publication produced by the NRCS, *Earth Dams and Reservoirs: Technical Release No. 60 (TR-60)*, was updated in 2005. See Appendix 5.1.1 for updated references.

### **5.7.3 Analysis Steps**

The WEF/ASCE *Manual of Practice No. 77* (1992) suggests, and El Dorado County endorses, the following steps for design of stormwater detention facilities:

1. Compute pre-development hydrograph from which the maximum catchment outflow is to be determined, as described in Section 5.7.1.
2. Compute post-development hydrograph that is to be “controlled” by the storage facility, as described in Section 5.7.1.
3. Subtract the pre-development runoff volume from the post-development volume. This volume difference represents the approximate storage requirement.
4. For the pond side, develop a table and/or curve of water-surface elevation v. storage.
5. Refer to the culvert design charts in Section 7 and determine a trial outlet size required to pass the maximum allowable outflow at a headwater depth corresponding to the storage requirement from step 3. Measure depth above the basin floor or lowest outflow pipe invert elevation.
6. For the trial outlet size, construct the storage-outflow relationship, as shown in Fig. 5.7.1.
7. Compute the outflow hydrograph, following the procedure in Section 5.7.2. Use  $\Delta t$  sufficiently small to permit definition of five or six ordinates on the rising limb of the inflow hydrograph. The computations for this step can be done with hand calculations, with a spreadsheet program, or with a specialized computer program.
8. Compare the maximum outflow rate with the allowable rate.
9. Adjust the size, shape, and/or outlet structure if the maximum rate exceeds the allowable rate, and repeat Steps 5-8.

Additional guidance is available from the Bureau of Reclamation, *Design of Small Dams* (1987).

The engineer must present all computations clearly to simplify review by the County.

### **Appendix 5.1 References**

Bureau of Reclamation (1987). *Design of Small Dams*. U.S. Department of the Interior. Washington, D.C.

Chow, V.T., Maidment, D.R., and Mays, L.W. (1988). *Applied Hydrology*. McGraw-Hill. New York, NY.

County of El Dorado (1988). *Grading, Erosion, and Sediment Control Ordinance*. (Ordinance No. 3983, 1988). Placerville, CA.

Division of Safety of Dams (1977). *Guidelines for the Design and Construction of Small Embankment Dams*. California Department of Water Resources. Sacramento, CA.

Hydrologic Engineering Center (1990). *HEC-1: Flood Hydrograph Package User's Manual*. USACE. Davis, CA.

Psomas and Associates (1991). *El Dorado County Drainage Manual (Draft)*. Sacramento, CA.

Soil Conservation Service (1985). "Earth Dams and Reservoirs." *Technical Report 60*. USDA. Springfield, VA.

U.S. Army Corps of Engineers (1965). "Hydraulic Design of Spillways," *Engineering Manual 1110-2-1603*. Office of Chief of Engineers. Washington, DC.

Water Environment Federation/American Society of Civil Engineers (1992). *Design and Construction of Urban Stormwater Management System*. New York, NY.

*See Appendix 5.1.1 for updated references*

### **Appendix 5.1.1 Updated References**

Listed below are the updated versions of select references for this section or references that were absent from the original *Drainage Manual*. If an updated version was not available, the original version should be referenced.

County of El Dorado (2010). *Grading, Erosion, and Sediment Control*. Ordinance No. 4949. Placerville, CA.

California Stormwater Quality Association (2003). *Stormwater Best Management Practice Handbooks*. State of California.

Hydrologic Engineering Center (1998). *HEC-1: Flood Hydrograph Package User's Manual*. USACE. Davis, CA

National Resources Conservation Service (2005). "Earth Dams and Reservoirs." *Technical Report 60 (TR-60)*. USDA. Washington, DC.

State of California (n.d.). Jurisdictional Sized Dams. Retrieved April 1, 2019, from <https://water.ca.gov/Programs/All-Programs/Division-of-Safety-of-Dams/Jurisdictional-Sized-Dams>.

U.S. Army Corps of Engineers (1992). "Hydraulic Design of Spillways." *Engineering Manual 1110-2-1603*. Department of the Army. Washington, DC.



*This page intentionally left blank.*

**Section  
6**

***Hydraulic Design of Open Channels***

This section discusses the types of channels to be constructed in El Dorado County. The specific criteria and issues that are to be considered in the design of such channels are also discussed.

**Contents of this section**

- 6.1 Background.....6-2
  - 6.1.1 Channel Types .....6-2
  - 6.1.2 Natural Channels Preferred .....6-3
  - 6.1.3 Channel Stability.....6-3
- 6.2 Analysis Procedures .....6-4
  - 6.2.1 Classification of Open Channel Flow .....6-5
  - 6.2.2 Manning’s Equation .....6-6
  - 6.2.3 Selection of Manning’s n Value .....6-6
  - 6.2.4 Uniform Flow .....6-9
  - 6.2.5 Critical Depth in Open Channels .....6-9
  - 6.2.6 Non-uniform Flow .....6-10
  - 6.2.7 Flow Analysis Using Hydraulic Computer Programs .....6-11
  - 6.2.8 Weir Flow.....6-12
- 6.3 Channel Design Criteria.....6-12
  - 6.3.1 Channel Alignment .....6-12
  - 6.3.2 Hydraulic Grade Line .....6-13
  - 6.3.3 Easements.....6-13
  - 6.3.4 Design Flow.....6-13
  - 6.3.5 Freeboard.....6-13
  - 6.3.6 Low Flow .....6-15
  - 6.3.7 Velocity Requirements.....6-15
  - 6.3.8 Use of Concrete Pipe in Place of an Open Channel.....6-17
  - 6.3.9 Typical Channel Sections .....6-17
  - 6.3.10 Design of Unreinforced Concrete Channels .....6-17
  - 6.3.11 Design of Reinforced Concrete Channels.....6-18
  - 6.3.12 Design of Rock Slope Protection for Channels.....6-18
- 6.4 Related Design Criteria.....6-21
  - 6.4.1 Energy Dissipators .....6-21
  - 6.4.2 Fencing.....6-22
  
- Appendix 6.1 References.....6-23
  - Appendix 6.1.1 Updated References.....6-24
- Appendix 6.2 Fencing Plan.....6-25

## **6.1 Background**

Once the appropriate level of protection is defined and the design discharge is computed according to the procedures in Section 2, a channel of appropriate size and shape can be designed. Once designed and constructed, this channel will protect adjacent areas from events that do not exceed the design event. In some cases, the level of protection can be increased significantly with a modest increase in cost. In all cases, the engineer should evaluate the consequences of events larger than the specified design events. Estimating the damage caused by a 500-year flood event with proposed improvements in place, and then verifying that the damage would not be worse than the no-improvement condition is an example of such an evaluation.

Extensive information is available on the hydraulic design of open channels. El Dorado County expects that the engineer will have substantial familiarity and experience with such information. The purpose of this section is therefore to cover the primary design issue, analysis procedures, and design criteria for open channels. In many cases, the engineer will have to refer to the referenced source materials to adequately investigate the details of a particular design. El Dorado County has adopted open channel design criteria that are substantially based on the following standard reference: USACE *Engineer Manual No. 1110-2-1601* titled, "Hydraulic Design of Flood Control Channels" (1991<sup>17</sup>). Design of energy dissipators and other in-channel control measures is based on: Federal Highway Administration *Hydraulic Engineering Circular No. 14* titled, "Hydraulic Design of Energy Dissipators for Culverts and Channels."

### **6.1.1 Channel Types**

A channel collects runoff from its contributing drainage area and conveys it to another point. Several types of channels that are acceptable in El Dorado County are discussed below.

*Natural Channels:* A natural channel is defined as an existing stream which has been created by hydrologic and geomorphologic processes. It typically has a minimum of improvements. A constructed, improved, or altered channel may be considered a natural channel if it is designed to function as a natural river system. The use, preservation, and enhancement of natural channels are preferred in El Dorado County.

---

<sup>17</sup> This publication produced by the USACE, *Engineer Manual No. 1110-2-1601*, was updated in 1994. See Appendix 5.1.1 for updated references.

*Improved Channels:* An improved channel is defined as facility specifically designed for the single purpose of collecting and conveying runoff in an efficient manner. Improved channels include grass lined, concrete lined, and rock lined channels.

*Grass Lined Channels:* Grass lined channels are improved channels with regular cross sections that are lined with grass to prevent erosion and treat and attenuate stormwater runoff. Grass lining is viable only for channels with relatively flat slopes. Successful grass lined channels require maintenance both for the establishment of the root network and to control the length of the grass.

*Concrete Lined Channels:* Concrete lining is used where maximum of conveyance is desired in limited right of way situations or where channel slopes are very steep. In general, concrete lining is used in commercial areas and high density subdivisions.

*Rock Lined Channels:* Rock lining such as rip rap and wire enclosed gabions offer a similar degree of erosion protection as concrete and is usually a lower cost solution. For wide channels or those with moderate slopes, the channel bed is usually left unlined and the bank lining extends below the bed to a depth which exceeds the potential scour depth. Rock lining is also used for local scour control at culverts, stream bends, and spillways and drop structures.

*Other Channel Linings:* When the designer proposes to use other linings such as geotextiles, flexible interlocking pavement, soil cement, etc., El Dorado County should be contacted.

### **6.1.2 Natural Channels Preferred**

The use of natural channels for the collection and conveyance of storm water runoff is the preferred method. The reason for this is that the preservation and enhancement of natural channels play a key role in maintaining the quality of habitat for fish and wildlife. It also preserves natural floodplain storage areas and provides aesthetic qualities that are consistent with the rural character of El Dorado County. Water quality treatment may be required prior to the discharge of stormwater into a natural channel.

### **6.1.3 Channel Stability**

During a rainfall event, increased runoff volumes from developed areas can contribute to bed and bank erosion of both natural and improved channels. Furthermore, dry season urban runoff can result in extensive

growth of channel vegetation that may reduce channel conveyance below intended design values. The designer's work is not complete unless the above two factors are taken into account.

In order to determine the proper type of channel stabilization and flood protection measures, the following issues should be considered during the planning and design of drainage improvements:

1. The effect that any changes in the runoff hydrograph may have upon the floodplain limits.
2. The effect that potential growth of vegetation in the channel or floodplain has upon the long-term flood protection of adjacent development.
3. The effect that channelization of an existing stream has upon the natural floodplain storage volume.
4. The effect that increases of either peak flow or velocity may have on the physical structure of a channel and erosion and/or deposition.
5. The effect that the proposed development project will have on both short-term and long-term flow and sediment production. This includes measures to control erosion during construction.
6. For projects which propose the creation or expansion of permanent water bodies: The effect that a change in water temperature will have upon fish and wildlife.
7. The role that drainage improvements will play in managing pollutants in storm water runoff.
8. The effect that the proposed drainage improvement has upon the existing aesthetic qualities of the area.

All of the above are not applicable to all drainage design projects. However, El Dorado County encourages multidisciplinary involvement in both the planning and design of major drainage projects to the extent that it results in preservation of natural systems and reliable flood protection for developed areas.

## **6.2 Analysis Procedures**

This section discusses analysis procedures appropriate for the hydraulic design of open channels. The types of computations requested do not require the use of computer programs. The use of computer programs is discussed, however.

### ***6.2.1 Classification of Open Channel Flow***

Open channel flow can be classified by considering the variation of the depth of flow with respect to either distance or time. If the depth of flow is constant over the entire length of the channel, the flow is termed uniform. If the depth of flow at a fixed point along the channel is constant over time, the flow is termed steady.

For most of the channels in El Dorado County, steady flow at the peak discharge can be assumed for hydraulic design purposes. If the channel is long, have constant cross section shape, and no backwater effects from downstream controls, the flow can be considered uniform and analyzed as such.

For steady, uniform conditions, water will flow at its normal depth. Normal depth occurs when the work done by gravity to move water is in equilibrium with the energy loss due to channel boundary roughness. Manning's equation computes the normal depth of flow for a given discharge.

For steep, high velocity channels, normal depth may be in the supercritical regime. This is when inertial forces are greater than gravitational forces. For flatter channels, velocities are slower and gravitational forces dominate, thus normal depth is usually in the subcritical regime. Improved channels are designed to maintain flow depths entirely in either the subcritical or supercritical range. The reason for this is that channels designed for critical depth often exhibit unstable flow patterns. When flow changes from the supercritical regime to the subcritical, a region of rapidly varied flow known as a hydraulic jump occurs. Specific channel design measures are usually employed to control the location of a hydraulic jump.

## 6.2.2 Manning's Equation

As discussed above, Manning's equation gives the normal depth for a given discharge assuming steady, uniform flow conditions:

$$Q = \frac{1.49AR^{2/3} S_f^{1/2}}{n} \quad (\text{Eq. 6.2.1})$$

in which, Q= discharge in ft<sup>3</sup>/sec; n= Manning's roughness coefficient; A= cross sectional area of flow in ft<sup>2</sup>; R is the hydraulic radius (area divided by wetted perimeter) in ft; S<sub>f</sub> is the slope of the energy grade line in ft/ft.

## 6.2.3 Selection of Manning's n Value

The selection of the appropriate Manning's n value(s) requires consideration of the ultimate purpose for which calculations based on that selected value are to be used.

For example, a channel is to be designed with the intention that it mimics a natural river system. The section shape is a wide trapezoid with a bed of coarse sand and 3:1 side slopes protected by rock facing. For the first few years after construction, channel roughness will be governed by the bed material and rock side slopes. An appropriate n-value for this condition might be 0.03. Since it is desired to allow the channel to obtain a natural appearance, a certain amount of vegetation is allowed to grow within the channel. After one or two decades, channel roughness will be governed by vegetation thus an appropriate n-value might be 0.08.

Both n-values are correct considering their specific physical conditions. The potential for error, however, arises in their application. If the value n=0.03 is used, the relatively high computed velocities will result in an adequate design for erosion protection. It will, however, underestimate potential flood stages under the vegetated condition. If the value n=0.08 is used, the resulting velocities will be too low resulting in inadequate bank protection measures. Computed flood stages, however, will be adequate.

The solution to this dilemma is to use a Manning's n value on the lower end of the expected range when the objective is to evaluate velocity dependent design criteria such as the scour depth or bank protection. When the objective is to determine depth dependent design criteria such as the maximum flood stage, a Manning's n value should be chosen which is on the higher end of the expected range and reflects the long-term characteristics of the proposed channel.

Table 6.2.1 gives recommended ranges of the Manning's n value for conditions that are commonly found in El Dorado County. The values are applicable to small and medium sized channels. The column labeled Lower End gives the n-value that should be considered for velocity based design criteria. The column labeled Normal Value gives the n-value that should be considered for depth based design criteria. These n values are based on data presented in the book, *Open-Channel Hydraulics* (Chow, 1959). When selecting the n-value from the Table 6.2.1, care, judgment and experience should be used. The presence of bed forms and gravel bars can often result in a higher n-value. Alternatively, flexible vegetation that lies down on the stream bed during a flood can often result in a lower n-value.



**Table 6.2.1 Typical Manning's n Values**  
(Source: Chow, 1959)

| Channel Description                                   | Low End n-Value | Normal n-Value |
|---|-----------------|----------------|
| Natural streams, Mild slopes:                         |                 |                |
| 1. Clean, straight, no rifts, or deep pools           | 0.025           | 0.030          |
| 2. Same as above, but more stones and weeds           | 0.030           | 0.035          |
| 3. Clean, winding, some pools and shoals              | 0.033           | 0.040          |
| 4. Same as above but some weeds and stones            | 0.035           | 0.045          |
| 5. Same as above, lower stages, more ineffective area | 0.040           | 0.048          |
| 6. Same as 4, more stones                             | 0.045           | 0.050          |
| 7. Sluggish reaches, weedy, deep pools                | 0.050           | 0.070          |
| 8. Very weedy, heavy stand of timber and underbrush   | 0.075           | 0.100          |
| Steep mountain streams, vegetation on banks only      |                 |                |
| 9. Bottom: gravel and cobbles, few boulders           | 0.030           | 0.040          |
| 10. Bottom: cobbles with large boulders               | 0.040           | 0.050          |
| Flood plains:   |                 |                |
| 11. Pasture, no brush, short grass                    | 0.025           | 0.030          |
| 12. Pasture, no brush, high grass                     | 0.030           | 0.035          |
| 13. Scattered brush, heavy weeds                      | 0.035           | 0.050          |
| 14. Light brush and trees in summer                   | 0.040           | 0.060          |
| 15. Dense willows, summer, straight                   | 0.110           | 0.150          |
| Improved earth channels:                              |                 |                |
| 16. Gravel, uniform section, clean                    | 0.022           | 0.025          |
| 17. With short grass, few weeds                       | 0.022           | 0.027          |
| 18. Winding, sluggish, stony bottom, weedy banks      | 0.025           | 0.035          |
| Unmaintained channels:                                |                 |                |
| 19. Dense weeds as high as flow depth                 | 0.050           | 0.080          |
| 20. Clean bottom, brush on sides                      | 0.040           | 0.050          |
| 21. Same, highest stage of flow                       | 0.045           | 0.070          |
| 22. Dense brush, high stage                           | 0.080           | 0.100          |
| Lined channels:                                       |                 |                |
| 23. Trowel finish                                     | n/a             | 0.013          |
| 24. Float finish                                      | n/a             | 0.015          |
| 25. Unfinished  | n/a             | 0.017          |
| 26. Gunite, regular                                   | n/a             | 0.019          |
| 27. Gunite, wavy                                      | n/a             | 0.022          |
| 28. Riprap (n-value depends on rock size)             | 0.020           | 0.030          |

### 6.2.4 Uniform Flow

For uniform flow, the energy grade line is parallel to the invert profile, thus  $S_f = S_0$ , the channel bed slope. Manning's equation can therefore be used to compute the normal flow depth, given the channel cross section shape, bed slope, and the  $n$  value.

The computation of normal depth using a given discharge can be accomplished by several methods: iterative calculations, hydraulic tables, or by graphical means such as those in *Open-Channel Hydraulics* (Chow, 1959).

For channels with rock slope protection, the value of Manning's  $n$  can be estimated directly from the Strickler equation:

$$n = K(D_{90\min})^{1/6} \quad (\text{Eq. 6.2.2})$$

in which,  $n$  = Manning's  $n$ ;  $K = 0.034$  for velocity computation or  $K = 0.038$  for flow depth computation;  $D_{90\min}$  = diameter in feet for which 90% of the sample is finer, from the lower limit curve of gradation.

For channels with surface roughness that varies across the channel section or in cases where over bank conditions are to be analyzed, a composite  $n$  value must be derived. The composite  $n$  is a weighted average based on the wetted perimeter. The basic relationship is:

$$n_{\text{composite}} = \frac{n_1 WP_1 + n_2 WP_2 + \dots + n_m WP_m}{WP_1 + WP_2 + \dots + WP_m} \quad (\text{Eq. 6.2.3})$$

in which  $n_j$  and  $WP_j$  are the Manning's  $n$  value and wetted perimeter, respectively, of a given roughness sub-section.

### 6.2.5 Critical Depth in Open Channels

Critical depth in a given channel section occurs when the specific energy ( $V^2 / 2g + \text{flow depth}$ ) is at a minimum for a given flow rate. Determination of whether the flow regime is normally supercritical (depth is less than critical depth) or subcritical (depth is greater than critical) is essential for open channel design.

For regular channel sections, the flow regime can be identified from the Froude number expressed as:

$$F = \frac{V}{(\sqrt{gA/T})} \quad (\text{Eq. 6.2.4})$$

in which  $F$  = Froude number;  $V$  = mean flow velocity;  $A$  = cross section area;  $T$  = top width. If the Froude number is 1, the channel is at critical depth. When a channel flows at critical depth, a minor change in specific energy can result in large change in depth. Designed channels should therefore have Froude a number less than 0.85 and greater than 1.10.

Designing channels for sub-critical flow is preferred when practical. High velocities, wave action, super-elevation, and potential for hydraulic jumps make super-critical channel design more difficult and construction more costly. However, the natural topography will generally determine the slope of a channel design; therefore, designing for super-critical flow may be unavoidable in steep terrain. If this is the case, special care must be taken to avoid any significant alignment, slope, roughness or channel geometric changes. In addition, scouring and momentum forces must be considered in the structural design of the channel and outlet facilities.

### **6.2.6 Non-uniform Flow**

For subcritical conditions, non-uniform flow occurs when a downstream condition causes upstream flow depths to be different from normal depth. These downstream conditions can include: a change in bed slope, a change in channel roughness, a channel shape transition, a tributary inflow, backwater from a receiving stream, or an in-channel structure. For non-uniform flow conditions, the flow depth at an upstream cross section can be computed from the known flow depth at a downstream section using the steady state, gradually varied flow equation:

$$\frac{\Delta y}{L} = \frac{S_0 - S_f}{1 - F^2} \quad (\text{Eq. 6.2.5})$$

in which,  $\Delta y$  = the change in water surface elevation from the downstream section to the upstream section in ft;  $L$  = the distance between sections in ft;  $S_0$  = the bed slope in ft/ft;  $S_f$  = the slope of the energy grade line in ft/ft;  $F$  = the Froude number.

By progressing in an upstream direction from a known water surface elevation, a non-uniform water surface profile can be computed using Section 6.2.5. For non-uniform flow calculations with compound channel cross sections, guidance on the estimation of the appropriate hydraulic

properties for non-uniform flow computation can be found in the USACE's *Volume 6 Water Surface Profiles* report by the Hydrologic Engineering Center (1975<sup>18</sup>).

For computation of non-uniform flow associated with the design of supercritical flow channels, consideration must be given to cross wave formation in transitions and bends as well as to flow depths and velocities. Guidance on supercritical flow analysis can be found in the USACE's *EM-1110-2-1601*.

### **6.2.7 Flow Analysis Using Hydraulic Computer Programs**

The purposes of steady flow, open channel hydraulic computer programs such as HEC-2 and HEC-RAS are to save time and to increase accuracy. Such programs are not a substitute for the understanding of the basic equations and principles of open channel hydraulics. The use of hydraulic computer programs is not mandatory. El Dorado County encourages their use, however, when the result is a more accurate and complete channel design study.

Computer programs HEC-2 and its successor, HEC-RAS, solves the one-dimensional energy equation for steady-state, non-uniform flow. Cross sections are specified by entering a series of up to 100 station-elevation points. Thus compound sections and natural floodplains can be dealt with accurately. Distances between cross sections and floodplain over banks are also entered. The programs start with specified downstream water surface elevation and compute the water surface elevation at successive upstream cross sections using Manning's equation to compute the frictional energy loss. The program also has the ability to account for other energy losses such as contractions, expansions, culverts, bridge piers, and weir flow losses.

The HEC-2 and HEC-RAS programs require the following general input: 1) Downstream control water surface elevation; 2) Cross section data of sufficient detail; 3) The design discharge for each cross section; 4) Tributary inflow or diversion locations; 5) Channel roughness n-values, expansion, and contraction coefficients; 6) Proper selection of cross section locations to account for changes in channel geometry or hydraulic conditions.

Information on training classes in the use of HEC-RAS is available through the USACE's HEC website.

---

<sup>18</sup> Volume 6 is part of the 12-volume report entitled "Hydrologic Engineering Methods for Water Resources Development," prepared by the HEC as part of the USACE's participation in the International Hydrological Decade.

### **6.2.8 Weir Flow**

Common uses of weir flow analysis in channel and storm drain calculations are for channel overflow spillways, analysis of roadway overtopping, and detention pond outlets. The general equation for rectangular, horizontal crested weirs is:

$$Q = CLH^{1.5} \quad (\text{Eq. 6.2.6})$$

in which Q is the flow over the weir in cfs; C is the weir discharge coefficient; L is the length of the weir in ft; H is the distance in ft between the upstream energy grade line and the weir crest for a free outfall condition, or the distance between the upstream energy grade line elevation and the downstream energy grade line elevation for a submerged outfall condition.

The value of C is available from several standard texts for different types of weirs. For hand calculations, the value of C should be modified if it is a function of head or of the degree of submergence. The special bridge and culvert options in HEC-2 and HEC-RAS allow the use of compound weir shapes, and they automatically account for submergence. Typical values of C range from 2.5 to 3.1 for broad crested weirs. The less efficient a weir is, the lower the value of C. For weir flow over a bridge with railings, C is approximately 2.6. For weir flow over a designed structure that is free from debris, C is approximately 3.0.

This discussion applies only to weirs that are either approximately perpendicular to the direction of flow or control the outflow from a detention pond. For side-channel weirs (those that are parallel to the direction of flow), contact El Dorado County for specific design criteria.

## **6.3 Channel Design Criteria**

This section discusses specific design criteria that apply to various elements of design. The goal of such criteria is to guide the engineer in designing an adequate facility that will provide reliable flood protection and meet the environmental objectives of El Dorado County. After following these criteria, the engineer should evaluate the overall soundness and function of the design. If deviations from these criteria are necessary, they should be documented and presented to El Dorado County in the design report.

### **6.3.1 Channel Alignment**

Horizontal and vertical alignment of open channels should follow the natural drainage paths as much as possible. Abrupt horizontal alignment changes should be avoided and abrupt changes in channel slope should be avoided.

**Tranquil Flow:** For tranquil flow, the minimum centerline radius for an improved open channel shall be 35 feet or 3 times the average channel width, whichever is greater. The average channel width is defined as the cross sectional area divided by the flow depth.

**Rapid Flow:** Large waves are generated by rapid flow in simple curves. Therefore a smaller rate of curvature is recommended. The minimum radius for channels with rapid flow is given by:

$$R_{\min} = \frac{4V^2W}{gy} \quad (\text{Eq. 6.3.1})$$

in which  $R_{\min}$  = minimum radius of channel centerline in ft;  $V$  = average channel velocity in ft/sec.;  $W$  = channel top width in ft;  $g$  = acceleration of gravity (32.2 ft/sec<sup>2</sup>); and  $y$  = flow depth in ft.

### **6.3.2 Hydraulic Grade Line**

The design hydraulic grade line, or water surface profile, shall be shown on all improvement plans for open channels as well as closed conduit systems. Supporting calculations should be attached.

### **6.3.3 Easements**

Drainage easements for open channels shall be provided as required by El Dorado County. In general, an easement for an open channel shall have sufficient width for the channel and access roads and adequate vehicle turn around areas. For smaller channels, lesser criteria may apply.

### **6.3.4 Design Flow**

Channels shall be designed to convey the appropriate recurrence interval runoff event as described in Section 1.

### **6.3.5 Freeboard**

Freeboard is the vertical distance between the top of the channel (or levee) and the water surface that prevails when the channel is carrying the design flow under normal conditions. The purpose of freeboard is to prevent overtopping of the channel (or levee) when any of the following factors exist during the design flood event but were not accounted for in the hydraulic calculation for the design of the channel:

1. Floating debris
2. Settlement of stream banks or levees
3. Deposition of sediment
4. Increased friction due to bed forms
5. Increased friction due to vegetation growth
6. Wave action
7. Wind setup
8. Ice and/or snow blockage
9. Survey measurement inaccuracies
10. Hydrologic and hydraulic uncertainties

For channels, including natural floodplains with up to date detailed flood insurance studies, the generally accepted minimum freeboard is 1 foot. For natural floodplains that are unstudied or have out of date studies, hydraulic analysis must be performed, and the minimum freeboard requirement is 1 foot. For the design of levees, the minimum freeboard is 3 feet. For curved channels, freeboard is measured from the outside, super elevated water surface (See below).

Most channels will require attention to several of the items in the list above. The engineer will be required to provide additional freeboard when any of the listed items have a reasonable probability of (either individually or in combination) causing the required minimum freeboard to be exceeded. Developed areas adjacent to natural streams are especially prone to the above listed factors.

For curved channels, the outside of a channel bend experiences a local increase in water surface or super elevation. This effect is not considered by one-dimensional hydraulic analysis approaches including HEC-2. It must be computed separately.

The equation for a super elevated water surface at a bend is:

$$\Delta y = C \frac{V^2 W}{gR} \quad (\text{Eq. 6.3.2})$$

in which  $\Delta y$  = the rise in water surface between a theoretical level water surface at the centerline and the outside super elevated water surface in

ft;  $C = 1.0$  for simple curves;  $V$  = mean flow velocity in ft/sec.;  $W$  = top width based on centerline elevation;  $g$  = acceleration of gravity, 32.2 ft/sec<sup>2</sup>;  $R$  = radius of channel centerline curvature.

### **6.3.6 Low Flow**

For constructed natural and grass lined channels, a low flow channel shall be provided to carry base flows within the channel. The capacity of the low flow channel shall be based on the engineer's determination of the baseflow. For constructed natural channels, the designed low flow channel may migrate over time. Concrete lined channels should have a dual cross slope of 1% creating a shallow V in the center of the channel. Channels constructed with gabion baskets should have a low flow channel in the center. Channels that are fully rock lined (with riprap) do not require a low flow channel.

### **6.3.7 Velocity Requirements**

El Dorado County realizes that tables of permissible velocity are commonly used in hydraulic design criteria. Most of this information is based on a survey of practicing engineers performed by Fortier and Scobey in 1926<sup>19</sup>. The role of such velocity criteria is to evaluate the performance of a design in the absence of supporting calculations or data. These permissible velocities are presented here, as general guidelines. El Dorado County would rather review calculations and supporting data that demonstrate the channel will function as intended rather than to rely solely on permissible velocity guidelines.

For example, if a grass lined channel is proposed, a shear stress analysis of the stability of the channel during its establishment period is much more useful than merely providing the design velocity under ultimate conditions.

**Minimum Velocity:** Constructed open channels shall be designed to maintain a minimum velocity that is sufficient to convey the inflowing sediment load through the system. As a guideline, flow velocities of less than 2 feet per second during the 10 year storm will probably not meet these criteria.

**Maximum Velocity:** When evaluating the stability of channel against bed and bank erosion, meeting the permissible velocity guideline does not necessarily mean that the channel will be stable. A sedimentation study may be required in order to make this determination.

---

<sup>19</sup> See Appendix 6.1.1 of updated references.



Table 6.3.1 shows general guidelines for maximum permissible velocities in open channels carrying water with colloidal silts. These values are based on data in *Open Channel Hydraulics* (French, 1988).

**Table 6.3.1 Permissible Velocity Guidelines**  
(Source: French, 1988)

| Material  | Permissible Velocity (ft/sec) |
|---|-------------------------------|
| 1. Fine sand, colloidal   | 2.5                           |
| 2. Ordinary firm loam   | 3.5                           |
| 3. Stiff clay, very colloidal                                   | 5.0                           |
| 4. Fine gravel  | 5.0                           |
| 5. Graded loam to cobbles                                       | 5.0                           |
| 6. Coarse gravel, noncolloidal                                  | 6.0                           |
| 7. Shales and hardpans  | 6.0                           |
| 8. Tall Fescue or similar light grasses on easily erodible soil | 3.0                           |
| 9. Same as above on erosion-resistant soils                     | 5.0                           |
| 10. Ordinary grass mixtures on easily erodible soils            | 4.0                           |
| 11. Same as above on erosion-resistant soils                    | 5.0                           |
| 12. Heavy grass such as Bermuda on easily erodible soils        | 6.0                           |
| 13. Same as above on erosion-resistant soils                    | 8.0                           |
| 14. Unreinforced concrete                                       | 10                            |
| 15. Reinforced concrete   | 25                            |
| 16. Grouted riprap  | 10                            |
| 17. UngROUTED riprap  | See Sec. 6.3.11               |
| 18. Gabions   | Manufacturer's guidelines     |

### **6.3.8 Use of Concrete Pipe in Place of an Open Channel**

In situations where the need for useable surface area makes an open channel, impractical or unsafe underground concrete pipe may be used. The designer should refer to Section 4 of the *Drainage Manual* for information on this type of conveyance system.

### **6.3.9 Typical Channel Sections**

Side Slopes. Constructed channels shall have maximum side slopes as indicated in Table 6.3.2:

**Table 6.3.2 Maximum Side Slopes for Constructed Channels**

|                                     |                                  |
|-------------------------------------|----------------------------------|
| 1. Reinforced concrete              | Vertical                         |
| 2. Unreinforced concrete            | 1.5H to 1V                       |
| 3. Flat cobbles hand laid in mortar | Vertical 4' max<br>or 1.5H to 1V |
| 4. Grouted riprap                   | 1.5H to 1V                       |
| 5. UngROUTED riprap                 | 2H to 1V                         |
| 6. Grass Lined                      | 3H to 1V                         |
| 7. Earth Lined                      | 3H to 1V                         |

Bottom Width. Lined channels shall have a minimum bottom width of 6 feet and shall have an access ramp for maintenance equipment. The access ramp shall be a minimum 10 feet wide and have a maximum grade of 10%. This requirement does not apply to minor drainage channels or V-ditches.

Constructed Natural Channels. As described in Section 6.1, constructed natural channels are designed to mimic natural channels. The typical section for such channels should be determined by field investigation and examination of natural existing conveyance systems.

### **6.3.10 Design of Unreinforced Concrete Channels**

The design of unreinforced concrete channels requires the appropriate hydraulic analysis calculations as described in Section 6.2. Adequate allowances for super elevation and freeboard should be made. Unreinforced concrete thickness should be 4" minimum for banks and 6" minimum for the stream bed. Weep holes with diameter of 2" and adequate side drainage shall be placed a minimum of 20' on center along the channel walls. Expansion joints shall be placed at a minimum of 20' intervals along the channel. Also see the section on cutoff depth.

### **6.3.11 Design of Reinforced Concrete Channels**

Concrete channels are often designed to convey flows at high velocities in the supercritical regime. El Dorado County has adopted the procedures stated in Paragraphs 2-1 through 2-7 of “Hydraulic Design of Flood Control Channels”, *EM-1110-2-1601* (USACE, 1991<sup>20</sup>) for the design of reinforced concrete supercritical flow channels. Supporting structural calculations must be provided with the design report submittal. Reinforced concrete thickness should be 8” minimum. Weep holes with a diameter of 2” and adequate side drainage shall be placed a minimum of 20’ on center along the channel walls. Expansion joints shall be placed at a minimum of 20’ intervals along the channel.

### **6.3.12 Design of Rock Slope Protection for Channels**

El Dorado County has adopted the rock slope protection criteria discussed in Paragraphs 3-1 through 3-8 of the “Hydraulic Design of Flood Control Channels”, *EM-1110-2-1601* (USACE, 1991<sup>19</sup>). The criteria are applicable to open channels not immediately downstream of stilling basins or other highly turbulent areas and channel slopes of less than 2%. A summary of these design criteria follows.

*Stone Shape.* The stones used for riprap protection should be predominantly angular in shape. Not more than 30% (by weight) of the stones distributed throughout the gradation should have an a/c ratio (longest dimension divided by shortest dimension) greater than 2.5. Not more than 15% of the stones should have an a/c ratio greater than 3.0. No stone should have an a/c ratio greater than 3.5.

*Unit Weight.* The minimum unit weight for riprap protection is 150 lb/ft<sup>3</sup>. The typical unit weight is 165 lb/ft<sup>3</sup>.

*Gradation.* Table 6.3.3 gives the recommended gradation ranges for riprap with a unit weight of 165 lb/ft<sup>3</sup>. The value  $D_{30min}$  is the average stone diameter in feet for which no more than 30% of the sample by weight should be finer. Once this value is known, the recommended gradation range can be determined by plotting the indicated maximum and minimum stone weights for each of the percent finer values: 15, 50, and 100.

---

<sup>20</sup> The sections cited above in *EM-1110-2-1601* were updated by USACE in 1994. See Appendix 6.1.1 for updated references.

**Table 6.3.3 Recommended Riprap Gradation Ranges  
Percent Finer by Weight (165 lb/ft<sup>3</sup>)  
(Source: USACE, 1994)**

| Value of<br>D <sub>30min</sub><br>(ft) | 100%<br>Finer<br>Max | 100%<br>Finer<br>Min | 50%<br>Finer<br>Max | 50%<br>Finer<br>Min | 15%<br>Finer<br>Max | 15%<br>Finer<br>Min |
|--|----------------------|----------------------|---------------------|---------------------|---------------------|---------------------|
| 0.48                                   | 86                   | 35                   | 26                  | 17                  | 13                  | 5                   |
| 0.61                                   | 169                  | 67                   | 50                  | 34                  | 25                  | 11                  |
| 0.73                                   | 292                  | 117                  | 86                  | 58                  | 43                  | 18                  |
| 0.85                                   | 463                  | 185                  | 137                 | 93                  | 69                  | 29                  |
| 0.97                                   | 691                  | 276                  | 205                 | 138                 | 102                 | 43                  |
| 1.10                                   | 984                  | 394                  | 292                 | 197                 | 146                 | 62                  |
| 1.22                                   | 1,350                | 540                  | 400                 | 270                 | 200                 | 84                  |
| 1.34                                   | 1,797                | 719                  | 532                 | 359                 | 266                 | 112                 |
| 1.46                                   | 2,331                | 933                  | 691                 | 467                 | 346                 | 146                 |
| 1.70                                   | 3,704                | 1,482                | 1,098               | 741                 | 549                 | 232                 |
| 1.95                                   | 5,529                | 2,212                | 1,638               | 1,106               | 819                 | 346                 |
| 2.19                                   | 7,873                | 3,149                | 2,335               | 1,575               | 1,168               | 492                 |

For unit weights other than 165 lb/ft<sup>3</sup>, the weights in Table 6.3.3 should be multiplied by the ratio: actual unit weight divided by 165.

*Layer Thickness.* The minimum thickness of the riprap layer is the greater of: 1) The spherical diameter of the upper limit of the W<sub>100</sub> stone, or 2) 1.5 times the spherical diameter of the upper limit of the W<sub>50</sub> stone. If construction is to take place while the channel has a significant depth of flow against the bank, riprap layer thickness should be increased by 50%. Once placed, the riprap layer should be smooth and uniform.

*Design Stone Size.* The design stone size is given by the following equation:

$$D_{30} = (SF)(C_s)(C_v)(\gamma) \left[ \frac{V_{ss}}{\{\sqrt{(sg - 1)K_1 g \gamma}\}} \right]^{2.5} \quad (\text{Eq. 6.3.3})$$

in which:

D<sub>30</sub> = The diameter of riprap for which 30% is finer by weight, ft.

SF = Safety factor. The minimum value is 1.1. This factor should be raised to address concerns over floating debris, ice, vandalism, and quality control.

C<sub>s</sub> = Stability coefficient. Use 0.30 for angular rock.

C<sub>v</sub> = Vertical velocity distribution coefficient:

- Use 1.0 for straight channels and inside bends.
- Use  $1.283 - 0.2 \log(R/W)$  for outside bends.
- Use 1.25 for braided channels.
- Use 1.25 downstream of concrete channels.
- Use 1.25 at the ends of a dike.

$y$  = Local flow depth in ft.

$sg$  = Specific gravity of riprap (unit weight of rock divided by unit weight of water).

$V_{ss}$  = The local flow velocity approximately 20% of the slope length up from the toe. This can be estimated from the computed mean channel velocity  $V$  by using the following relationships:

- Use  $V_{ss} = V \{1.71 - 0.78 \log(R/W)\}$  for trapezoidal channels with  $R/W$  less than 13.
- Use  $V_{ss} = 0.82 V$  for trapezoidal channels with  $R/W$  greater than 13 and for straight channels.
- Use  $V_{ss} = V \{1.74 - 0.52 \log(R/W)\}$  for natural channels with  $R/W$  less than 40.
- Use  $V_{ss} = 0.90 V$  for natural channels with  $R/W$  greater than 40 and for straight channels.
- Use  $V_{ss} = 1.6 V$  for braided channels, curved or straight.

$K_1$  = Side slope correction factor.

- Use 0.88 for 2H to 1V side slopes.
- Use 0.95 for 2.5H to 1V side slopes.
- Use 0.98 for 3H to 1V side slopes.

$g$  = acceleration of gravity, 32.2 ft<sup>2</sup>/sec.

Notes:  $R$  is the radius of the channel centerline in ft.  $W$  is the top width of the channel in ft. The term  $\log$  means the base 10  $\log$ .

Once the riprap size is determined, the assumed value of Manning's  $n$  should be verified using Equation 6.2.2. If it is not in reasonably close agreement, new hydraulic calculations should be made based on the revised  $n$ -value. A new stone size can then be computed.

*Cutoff Depth.* For channels that have banks lined with riprap or concrete but have an unlined stream bed, the engineer is required to determine how deep the slope protection should extend below the design invert. This distance is known as the cutoff depth. Guidance is available on the determination of the cutoff depth from *Hydraulic Engineering Circular No. 18 (HEC-18)*, Sections 2.1 through 2.5.3 (Federal Highway Administration,

1993<sup>21</sup>). The cutoff depth must exceed the potential total scour depth. The potential total scour depth is composed of four elements as shown in Table 6.3.4. The important elements to consider for different types of channels are also indicated in the table.

**Table 6.3.4 Elements of Total Scour Depth**

| Element of Total Scour      | Use for Straight Channels | Use for Curved Channels | Use for Channel Contractions |
|-----------------------------|---------------------------|-------------------------|------------------------------|
| 1. Long term degradation.   | X                         | X                       | X                            |
| 2. Contraction scour.       |                           |                         | X                            |
| 3. Local scour.             |                           | X                       | X                            |
| 4. Lateral migration scour. | X                         | X                       | X                            |

Supporting calculations for the design cutoff depth should be provided along with the hydraulic design study.

*Filter.* A suitable filter fabric or graded sand and gravel filter shall be placed below the bedding layer of all slopes protected by ungrouted riprap.

*Durability.* The rock shall have a minimum durability index of 52 according to Caltrans *Standard Specifications*, Paragraph 72-2.02, January, 1988<sup>22</sup>. The absorption should be less than 4.2%.

*Additional Guidance.* Usually the full height of the channel bank or levee is covered with rock protection. For channel bends, additional riprap protection is usually necessary along the bend. This additional riprap should extend both upstream and downstream of the bend for a distance of 1.5 times the channel top width.

## **6.4 Related Design Criteria**

### **6.4.1 Energy Dissipators**

An energy dissipator is a structure intentionally designed to safely bring flowing water from a higher energy state to a lower energy state. Locations where energy dissipators are needed include: at the outlet of a culvert, at the end of a spillway, downstream from a drop structure, within a steep chute, etc. The types of energy dissipators include: riprap, baffle

<sup>21</sup> This publication produced by the Federal Highway Administration, "Evaluating Scour at Bridges" *Hydraulic Engineering Circular No. 18 (HEC-18)*, was updated in 2012. See Appendix 6.1.1 for updated references.

<sup>22</sup> This publication produced by Caltrans, *Standard Specifications*, is continually updated. The latest version is 2018. See Appendix 6.1.1 for updated references.

block, stilling basin, abrupt transition, check dams, and controlled hydraulic jump.

For the design and construction of energy dissipators, El Dorado County has adopted the criteria in *HEC-14*, (Federal Highway Administration, 2006). The type and size of a dissipator depends on its particular function and context.

#### **6.4.2 Fencing**

Fencing, consisting of 6-foot chain link fencing per the latest version of Caltrans Chain Link Fence Standard Plans A85, may be provided around the perimeter of all lined channel easements with channel side slopes steeper than 3:1. The goal of fencing is to protect the public from dangerous conditions. Under certain circumstances, the engineer will have to work with El Dorado County in order to provide adequate access control.

## **Appendix 6.1 References**

California Department of Transportation (1992). *Standard Specifications*. Sacramento, CA.

Chow, V. T. (1959). *Open-Channel Hydraulics*. McGraw-Hill Book Company. New York.

Federal Highway Administration (1983). "Hydraulic Design of Energy Dissipators for Culverts and Channels." *Hydraulic Engineering Circular No. 14 (HEC 14)*. Washington, D.C.

Federal Highway Administration (1993). "Evaluating Scour at Bridges." *Hydraulic Engineering Circular No. 18 (HEC-18)*. Washington, D.C.

French, R. H. (1988). *Open Channel Hydraulics*. Water Resources Publications, LLC. Highlands Ranch, CO.

Hydrologic Engineering Center (1975). *Volume 6 Water Surface Profiles*. USACE and International Hydrological Decade. Davis, CA.

Hydrologic Engineering Center (1990). "HEC-2 Water Surface Profiles, User's Manual." USACE. Davis, CA.

U.S. Army Corps of Engineers (1991). "Hydraulic Design of Flood Control Channels." *Engineering Manual 1110-2-1601*. Office of the Chief of Engineers. Washington, D.C.

*See Appendix 6.1.1 for updated references*



### **Appendix 6.1.1 Updated References**

Listed below are the updated versions of select references for this section or references that were absent from the original *Drainage Manual*. If an updated version was not available, the original version should be referenced.

California Department of Transportation (2018). *Standard Specifications*. Sacramento, CA.

California Stormwater Quality Association (2003). *Stormwater Best Management Practice Handbooks*. State of California.

Federal Highway Administration (2006). "Hydraulic Design of Energy Dissipators for Culverts and Channels." *Hydraulic Engineering Circular No. 14*. Fairfax, VA.

Federal Highway Administration (2012). "Evaluating Scour at Bridges: Fifth Edition." *Hydraulic Engineering Circular No. 18 (HEC-18)*. Washington, D.C.

Fortier and Scobey (1926). "Special Committee on Irrigation." American Society of Civil Engineers. New York, NY.

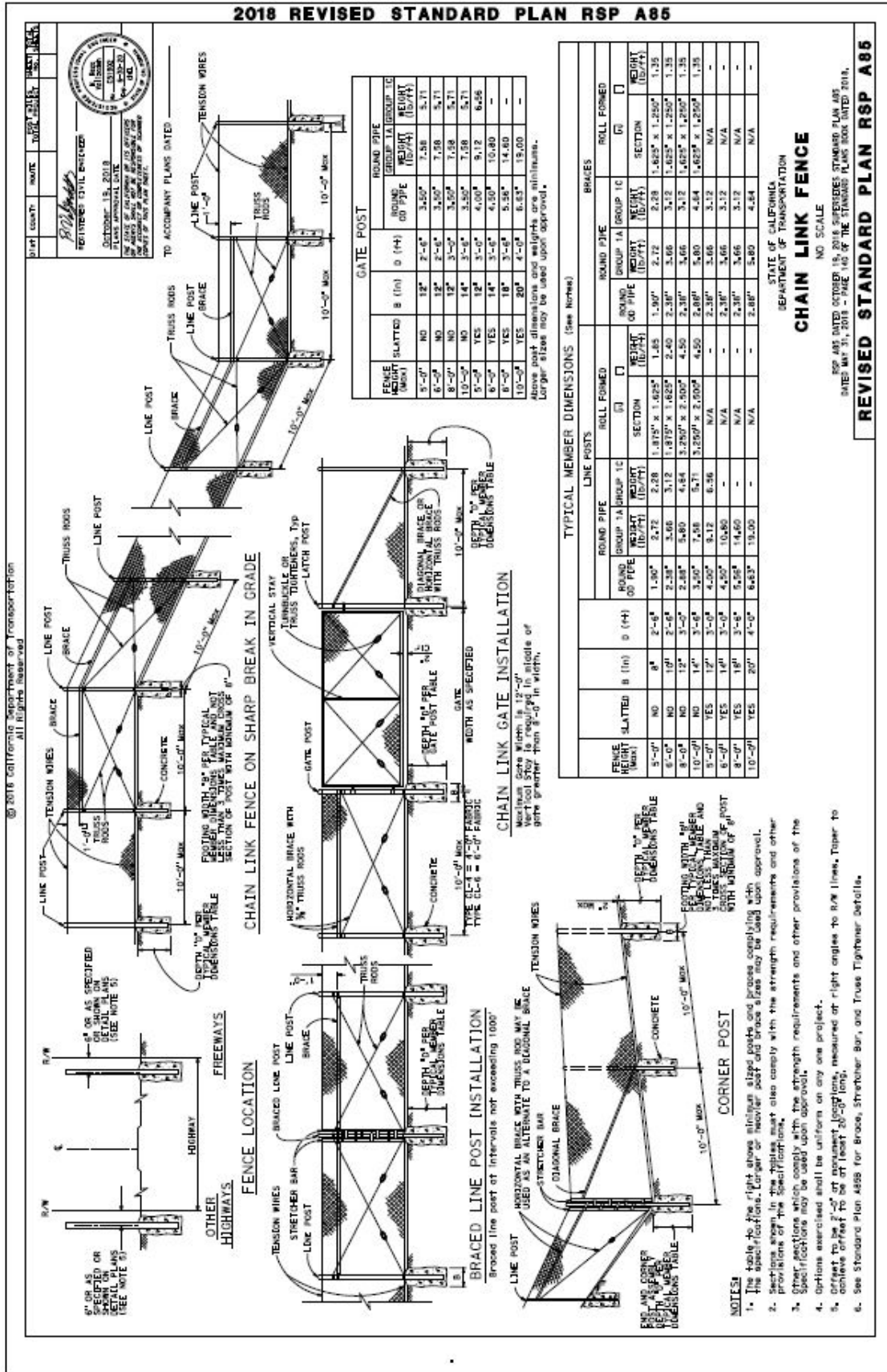
French, R. H. (2007). *Open Channel Hydraulics*. Water Resources Publications, LLC. Highlands Ranch, CO.

Hydrologic Engineering Center (1992). *HEC-2 Water Surface Profiles Program*. USACE. Davis, CA.

Hydrologic Engineering Center (2018). *HEC-RAS: Hydrologic Modeling System HEC-HMS User's Manual*. USACE. Davis, CA

U.S. Army Corps of Engineers (1994). "Hydraulic Design of Flood Control Channels." *Engineering Manual 1110-2-1601*. Office of the Chief of Engineers, Washington, D.C.

# Appendix 6.2 Fencing Plan





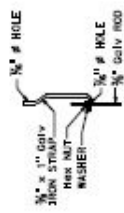
|      |        |       |      |           |          |
|------|--------|-------|------|-----------|----------|
| DATE | COUNTY | ROUTE | TYPE | POST MILE | PLAN NO. |
|      |        |       |      |           |          |

REGISTERED CIVIL ENGINEER

MOY 31, 2018

STATE OF CALIFORNIA  
DEPARTMENT OF TRANSPORTATION  
DIVISION OF HIGHWAYS

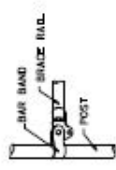
- NOTES:**
- All material for abutment connection to be galvanized.
  - The chain link fabric shall be replaced by barbed wire in areas of 15' maximum centers between the double posts.
  - When the width of the culvert is less than 10' necessary, it shall be made a part to the east of the culvert, a cast iron shoe or other device approved by the Engineer, shall be used.
  - Fencing over stream and around headwall may also use barbed wire or wire mesh fencing with either wood post or steel post installation.
  - See Standard Plan A85 for Chain Link fence dimensions, materials and for wood post and steel post installation.



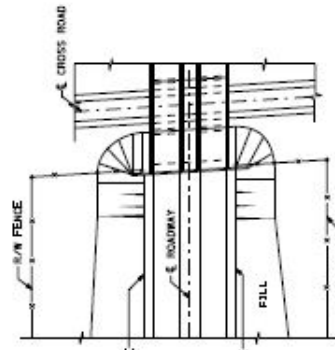
**TRUSS TIGHTENER**



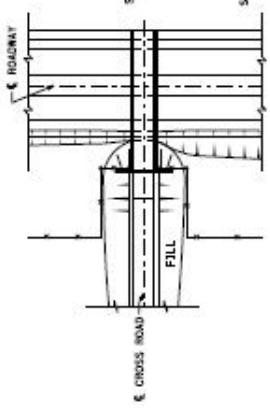
**STRETCHER BAR**



**BRACE RAIL**



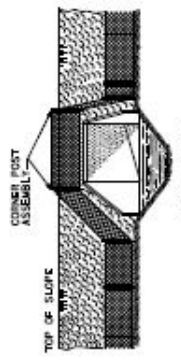
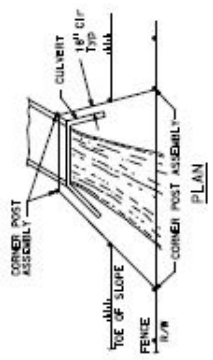
**PLAN OF ROADWAY - UNDERCROSSING**



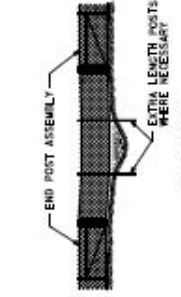
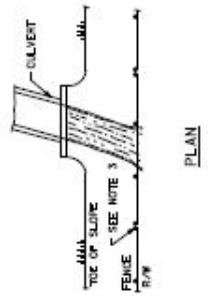
**PLAN OF ROADWAY - OVERCROSSING**



**TYPICAL INSTALLATION AT BRIDGES**



**INSTALLATION AROUND HEADWALL**



**INSTALLATION OVER STREAM**

**CHAIN LINK FENCE DETAILS**  
NO SCALE

**A85B**

STATE OF CALIFORNIA  
DEPARTMENT OF TRANSPORTATION

*This page intentionally left blank.*

**Section  
7**

**Hydraulic Design of Culverts**

This section discusses the principles to be used for the design and analysis of culverts in El Dorado County.

**Contents of this section**

- 7.1 Background..... 7-2
  - 7.1.1 Culvert Shapes ..... 7-2
  - 7.1.2 Culvert Materials..... 7-3
  - 7.1.3 Culvert Inlet Types..... 7-3
- 7.2 Analysis Procedures ..... 7-3
  - 7.2.1 Classification of Flow in Culverts ..... 7-3
  - 7.2.2 Types of Inlet Control ..... 7-4
  - 7.2.3 Types of Outlet Control..... 7-6
  - 7.2.4 Analysis Procedure..... 7-8
  - 7.2.5 Nomograph Design Chart Procedure ..... 7-8
  - 7.2.6 Computer Programs for Culvert Analysis ..... 7-10
  - 7.2.7 Analysis of Grates on Culvert Openings..... 7-11
- 7.3 Culvert Design Criteria..... 7-11
  - 7.3.1 Water Surface Elevation ..... 7-11
  - 7.3.2 Culvert Material ..... 7-11
  - 7.3.3 Erosion Protection ..... 7-12
- Appendix 7.1 References..... 7-13
  - Appendix 7.1.1 Updated References..... 7-14
- Appendix 7.2 Culvert Hydraulics Nomograph Design Charts..... 7-15

## **7.1 Background**

A culvert is a hydraulically short conduit which conveys streamflow through a roadway or other type of embankment. Culverts are constructed from a variety of materials and are available in many different shapes and configurations. Culverts are used for two primary purposes: To pass flow under a roadway, and to regulate flow coming out of a detention basin.

The appropriate level of protection for a culvert is defined in Section 1. The design discharge is computed according to the procedures in Section 2.4 or 2.5. If the culvert is being used as an outlet for a detention basin, the design hydrograph is needed in addition to the peak flow. The engineer should evaluate the consequences of events larger than the specified design events. Determining the ponding depth in a detention basin for a 500-year flood event, and then verifying that the upstream damage would not be worse than the no-improvement condition is an example of such an evaluation.

Extensive information is available on the hydraulic design of culverts. El Dorado County expects that the engineer will have substantial familiarity and experience with such information. The purpose of this section is therefore to cover the primary design issues, analysis procedures, and design criteria for culverts. In many cases, the engineer will have to refer to the referenced source materials to adequately investigate the details of a particular design. El Dorado County has adopted culvert design criteria that are substantially based on the following standard reference: Federal Highway Administration, "Hydraulic Design of Highway Culverts", *Hydraulic Design Series Number 5 (HDS-5)* (1985<sup>23</sup>).

### **7.1.1 Culvert Shapes**

Culverts have many different cross sectional shapes. The most commonly used shapes include circular, box, elliptical, pipe-arch, and arch. The selection of the shape includes factors such as constraints on the upstream water surface elevation, the roadway or embankment height, hydraulic performance, and the construction cost.

---

<sup>23</sup> This publication produced by the Federal Highway Administration, "Hydraulic Design of Highway Culverts" *Hydraulic Design Series Number 5 (HDS-5)*, was updated in 2012. See Appendix 7.1.1 for updated references.

### **7.1.2 Culvert Materials**

The selection of a culvert material includes factors such as structural strength, hydraulic roughness, durability, and abrasion resistance. The most commonly used culvert material types are reinforced concrete, corrugated steel, and corrugated aluminum.

### **7.1.3 Culvert Inlet Types**

Various inlet types are available to increase the hydraulic efficiency of water flowing into a culvert barrel. Inlet types include: Projecting pipes, prefabricated or cast in place head walls, mitered culvert ends conforming to slope. Since the upstream channel is usually much wider than the culvert barrel, the selection of the proper inlet can be critical to the proper design of a culvert.

## **7.2 Analysis Procedures**

This section discusses analysis procedures appropriate for the hydraulic design of culverts. The types of computations addressed do not require the use of computer programs. The use of computer programs for the design of culverts is discussed, however.

### **7.2.1 Classification of Flow in Culverts**

Perhaps the most important part of culvert analysis is the proper classification of flow regime and the understanding of how the flow regime changes under different discharge conditions. Culvert flow can be classified under two major categories: Inlet control and outlet control. Inlet control occurs when the flow capacity of the culvert entrance is less than the flow capacity of the culvert barrel. Outlet control flow occurs when the culvert capacity is limited by downstream conditions or by the flow capacity of the culvert barrel.

For inlet control, the required headwater is computed by assuming that the culvert inlet acts as an orifice or as a weir. Therefore, the inlet control capacity depends primarily on the geometry of the culvert entrance. For outlet control the required headwater is computed by taking the depth of flow at the culvert outlet, adding all head losses, and subtracting the change in flow-line elevation of the culvert from the upstream to the downstream end (HEC, 1990).

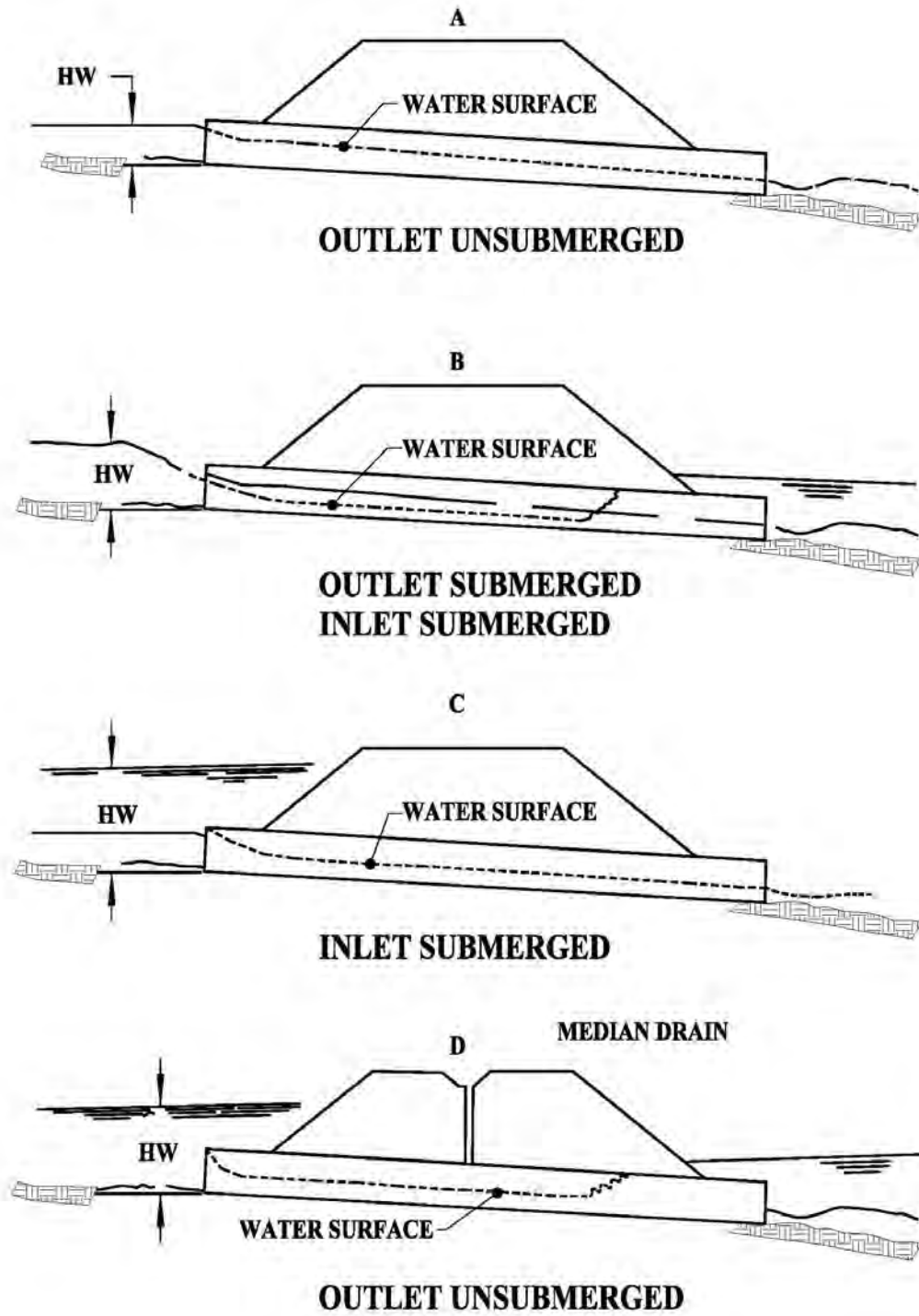


## 7.2.2 Types of Inlet Control

There are four types of inlet control as shown in Figure 7.2.1. The type of inlet control depends on the submergence condition of the upstream end of the culvert.

- *Inlet Control Type 1*  
Part A of Figure 7.2.1 shows the condition where neither the inlet nor the outlet end of the culvert is submerged. The flow passes through critical depth just downstream of the culvert entrance and the flow in the barrel is supercritical. The barrel flows partly full over its length and the flow approaches normal depth at the outlet end.
- *Inlet Control Type 2*  
Part B of Figure 7.2.1 shows submergence at the outlet but an unsubmerged condition at the inlet. Flow is supercritical in the barrel and a hydraulic jump occurs toward the downstream end.
- *Inlet Control Type 3*  
Part C of Figure 7.2.1 is a more typical design situation. The inlet end is submerged and the outlet end flows freely. Again the flow is supercritical and barrel flows partly full over its length. Critical depth is located just downstream of the culvert entrance and the flow is approaching normal depth at the downstream end of the culvert.
- *Inlet Control Type 4*  
Part D of Figure 7.2.1 shows a more unusual condition that has both inlet and outlet submerged. The culvert barrel does not flow full however. The median drain provides ventilation of the culvert barrel. If the barrel were not ventilated, negative air pressures could develop which might create an unstable condition during which the barrel would alternate between full flow and partially full flow.

For inlet control, the shape of the entrance transition is almost the sole factor that determines the amount of head loss through the culvert. It is interesting to note that the culvert barrel slope will play only a minor role in determining the overall efficiency of the culvert.



*Figure 7.2.1 Schematic Diagram of Types of Inlet Control for Culvert Flow.  
 (Source: FHWA, 2005)*

### **7.2.3 Types of Outlet Control**

Figure 7.2.2 shows the 5 types of outlet control for culvert flow. In each case, the control section is at the end of the culvert or further downstream.

- *Outlet Control Type 1*  
Part A of Figure 7.2.2 represents the classic outlet control situation. Both the inlet and outlet are submerged. The barrel is under pressure flow conditions for its entire length. This condition seldom exists in practice.
- *Outlet Control Type 2*  
Part B of Figure 7.2.2 shows the outlet submerged with the inlet unsubmerged. For this Case, the headwater is shallow so the inlet crown is exposed as the flow contracts into the culvert.
- *Outlet Control Type 3*  
Part C of Figure 7.2.2 depicts the entrance submerged to such a degree that the culvert flows full throughout its entire length while the exit is unsubmerged with high outlet velocities. This condition seldom occurs in practice.
- *Outlet Control Type 4*  
Part D of Figure 7.2.2 represents the typical condition. The culvert entrance is submerged by the headwater, and the outlet end flows freely with a low tailwater. For this condition, the barrel flows partly full over at least part of its length (subcritical flow), and the flow passes through critical depth just upstream of the outlet.
- *Outlet Control Type 5*  
Part E of Figure 7.2.2 is also typical, with neither the inlet nor the outlet submerged. The barrel flows partly full over its entire length under subcritical flow.

There are several factors influencing outlet control. The efficiency of the inlet plays a role for outlet control culverts as well as for inlet controlled ones. The length, slope, and roughness of the culvert barrel also play a key role in the overall efficiency of outlet controlled culverts. Perhaps the main factor is the elevation of the tailwater. This may be controlled by the cross section shape of the culvert outlet or by conditions further downstream such as heavy vegetation or a channel constriction.

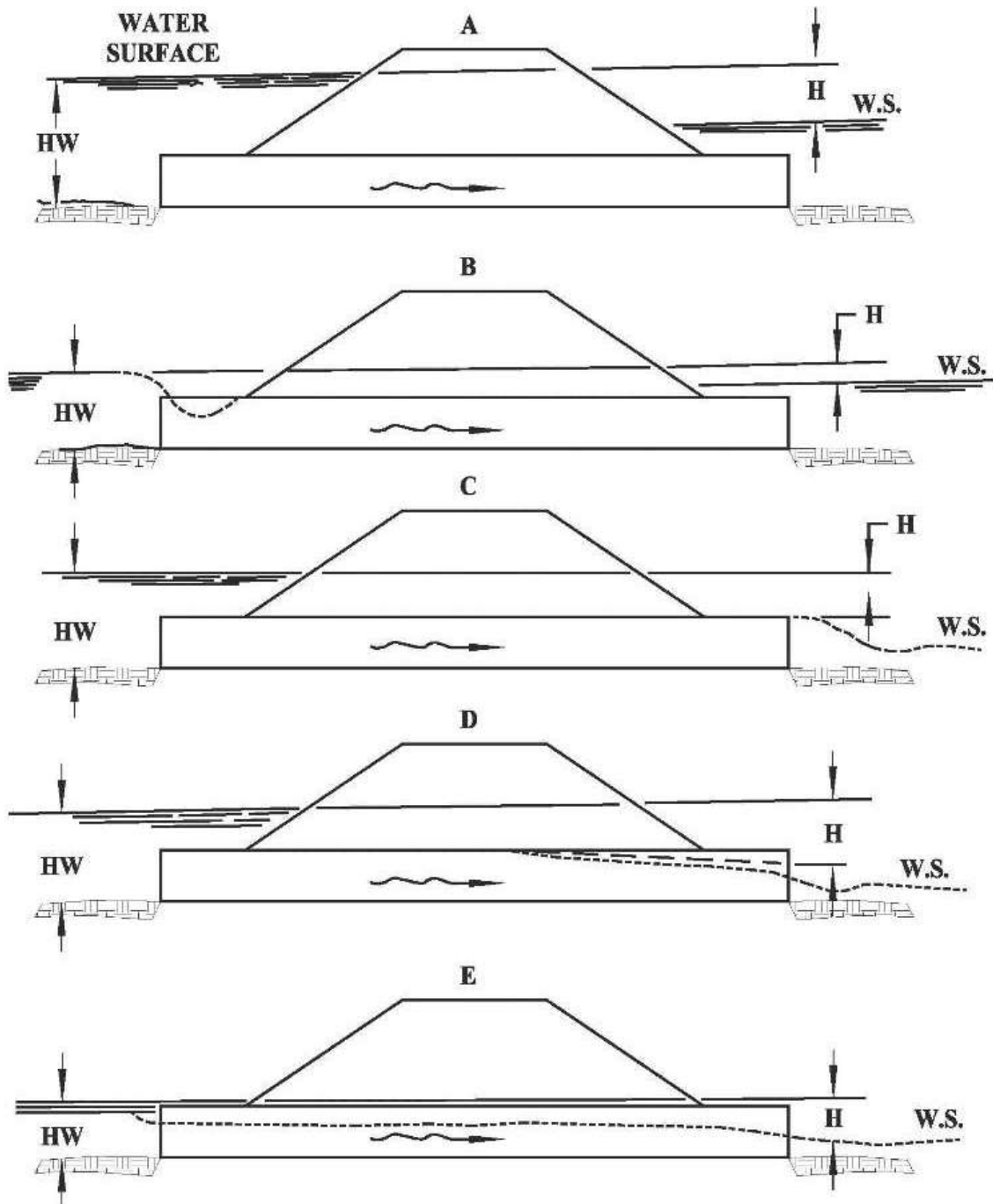


Figure 7.2.2 Schematic Diagram Showing Types of Outlet Control for Culvert Flow.  
 (Source: FHWA, 2005)

### **7.2.4 Analysis Procedure**

The purpose of hydraulic analysis for culverts is, in general, to determine the energy loss through the culvert in order to compute the upstream water surface elevation given the downstream water surface elevation. The generalized expression for the energy loss is:

$$H_L = H_e + H_f + H_o + H_b + H_j + H_g \quad (\text{Eq. 7.2.1})$$

in which  $H_L$  = the total energy loss;  $H_e$  = the entrance loss;  $H_f$  = the frictional energy loss of flow through the culvert barrel;  $H_o$  = the exit loss;  $H_b$  = the energy loss due to bends in the culvert barrel;  $H_j$  = the energy loss due to pipe junctions within the culvert; and  $H_g$  = the energy loss due to inlet or outlet grates.

For inlet controlled culverts, the entrance loss  $H_e$  is the primary quantity of concern. For outlet controlled culverts, the entrance loss  $H_e$ , the friction loss  $H_f$ , and the exit loss,  $H_o$ , are primary quantities of concern. When there are bends or junctions within the culvert, refer to Section 4.2.8 for guidance on computing energy losses. When the culvert has an inlet or outlet grate, refer to Section 7.2.6 for guidance on computing the energy loss.

Two analysis procedures are available to aid in computing energy losses in culverts: Nomograph design charts, and computer programs. These are discussed in the following two sections.

### **7.2.5 Nomograph Design Chart Procedure**

The Federal Highway Administration, the National Bureau of Standards and other agencies have compiled substantial laboratory and field data on culverts with different material types, inlet types, flow conditions etc. The analysis of this data has led to a series of design charts that are summarized in *HDS-5* (2005, 2012). The advantage of using these design charts is that it allows the engineer to determine the upstream energy grade line elevation for a given culvert design without breaking the loss down into specific quantities. These nomograph design charts are straightforward to use. The results of the charts typically have an accuracy of 10% if they are used for conditions that are reasonably similar to the laboratory and field conditions upon which the charts are based (HEC, 1990). Table 7.2.1 shows the categories for which the design charts can be used. The design charts are also provided in Appendix 7.2.

**Table 7.2.1 Nomograph Design Chart Categories**  
(Source: HDS-5, 2005, 2012)

| <b>Culvert Type and Flow Condition</b>                   | <b>Design Chart Nos.</b> |
|--|--------------------------|
| Circular Pipes of Various Materials with Inlet Control   | 1 – 3                    |
| Critical Depth in Circular Pipes                         | 4                        |
| Circular Pipes of Various Materials with Outlet Control  | 5 – 7                    |
| Concrete Box Culverts with Inlet Control                 | 8 – 13                   |
| Critical Depth in Box Culverts                           | 14                       |
| Concrete Box Culverts with Outlet Control                | 15                       |
| Corrugated Metal (C.M.) Box Culverts with Inlet Control  | 16 – 19                  |
| Critical Depth for Corrugated Metal (C.M.) Box Culverts  | 20                       |
| Corrugated Metal (C.M.) Box Culverts with Outlet Control | 21 – 28                  |
| Elliptical Concrete Pipe Culverts with Inlet Control     | 29 – 30                  |
| Critical Depth for Elliptical Concrete Pipe Culverts     | 31 – 32                  |
| Elliptical Concrete Pipe Culverts with Outlet Control    | 33                       |
| Pipe Arch Culverts with Inlet Control                    | 34 – 36                  |
| Critical Depth for Pipe Arch Culverts                    | 37 – 38                  |
| Pipe Arch Culverts with Outlet Control                   | 39 – 40                  |
| Arch Culverts with Inlet Control                         | 41 – 43                  |
| Critical Depth for Arch Culverts                         | 44                       |
| Arch Culverts with Outlet Control                        | 45 – 50                  |
| Flow Properties for Structural Plate Conduits            | 51 – 54                  |
| Head Loss for Side- or Slope-Tapered Inlets              | 55 – 59                  |

For the outlet control nomographs, the value of the entrance loss coefficient  $K_e$  must be determined from Table 7.2.2. It should be noted that the design charts assume a barrel slope of 2%. Additional frictional energy loss should be estimated for slopes significantly greater than 2%. For typical Manning's  $n$  values for culvert materials, refer to Table 4.2.1.

**Table 7.2.2 Entrance Loss Coefficients for Culvert Analysis  
(Source: Hydrologic Engineering Center, 1990)**

| <b>Concrete Box Culverts</b>  | <b>K<sub>e</sub></b> |
|---|----------------------|
| Headwall Parallel to Embankment:<br>Square Edges on 3 Sides           | 0.50                 |
| Round Edges on 3 Sides (Radius = 1/12 width)                          | 0.20                 |
| Wingwalls at 15 to 45 degrees:<br>Square Edge on Top Corner of Barrel | 0.40                 |
| Round Edge on Top (Radius = 1/12 width)                               | 0.20                 |
| <b>Pipe Culverts</b>  | <b>K<sub>e</sub></b> |
| Concrete Pipe, Projecting (No Headwall):<br>Socket End of Pipe        | 0.20                 |
| Square End of Pipe  | 0.50                 |
| Concrete Pipe with Headwall and Wingwalls:<br>Socket End of Pipe      | 0.10                 |
| Square End of Pipe  | 0.50                 |
| Rounded Entrance (Radius = 1/12 of Diameter)                          | 0.10                 |
| Corrugated Metal Pipe:<br>Projecting from Fill, No Headwall           | 0.80                 |
| With Headwall and Wingwalls, Square Edge                              | 0.50                 |

### **7.2.6 Computer Programs for Culvert Analysis**

Several computer programs are available for the analysis of culverts. A few programs that are well documented and are widely used in design practice are discussed here.

Computer program HEC-2 (HEC, 1990) and its successor, HEC-RAS (HEC, 2018) have the ability to analyze flow through culverts in a stream channel. They assume a constant, steady flow through the culvert. These programs are most useful when designing culverts as part of a channel improvement project or when evaluating the backwater effect of an existing culvert for a floodplain study.

Computer program HY-8 (FHWA, 1987 and GKY & Associates, Inc., 1992<sup>24</sup>) analyzes the flow through one or more culverts. It computes the headwater elevation for a range of specified outflows and tailwater conditions. The results of this program can be used to develop a storage volume vs. outflow rating curve making this program useful for detention basin analysis. Detention basin routing using HEC-1 can be done by entering the culvert outlet discharge on the SQ record, and either the

---

<sup>24</sup> This user's manual produced by the GKY and Associates, "HYDRAIN – Integrated Drainage Design Computer System, Volume VI, HY8 – Culverts", was updated in 1999. See Appendix 7.1.1 for updated references.

corresponding volume, surface area, or ponding elevation on the SV, SA, or SE record, respectively.

Information on training courses in the use of these programs is available through the USACE's HEC website. The HY-8 Computer Program and documentation is available through the McTrans Center for Microcomputers in Transportation, University of Florida in Gainesville.

### ***7.2.7 Analysis of Grates on Culvert Openings***

When a safety grate or a debris control measure is required to be placed at the inlet or the outlet of a culvert, analysis of its effect is required. If debris blocks the opening of the grate, additional energy loss will occur. Often culverts have to be oversized when they include grated entrances. When access control or debris control is required, reference is made to "Hydraulic Performance of Culverts with Safety Grates", FHWA, 1983.

## **7.3 Culvert Design Criteria**

This section discusses the specific design criteria that apply to various elements of design. The goal of such criteria is to guide the engineer in designing an adequate facility that will provide reliable flood protection and meet the environmental objectives of the county by incorporating water quality and habitat enhancement features. After following the analysis procedures and design criteria in this section, the engineer should evaluate that overall soundness and function of the design. If deviation from these criteria is necessary, they should be documented and presented to the county in the design report.

### ***7.3.1 Water Surface Elevation***

Culvert designs are subject to all of the water surface and freeboard criteria as discussed in Section 6, Hydraulic Design of Open Channels. For new culverts, the design water surface elevation should be at least 2 feet below the minimum roadway elevation.

### ***7.3.2 Culvert Material***

Most culverts will be constructed of either corrugated metal or reinforced concrete. The wall thickness and amount of reinforcing depends on the depth of cover and the loading conditions that will occur on the culvert.



Refer to Caltrans *Highway Design Manual* for the determination of culvert loading and material specification.

### **7.3.3 Erosion Protection**

A culvert often creates areas of concentrated velocity as the flow contracts or expands. The culvert design must address this and mitigate potential erosion problems by the placement of wing walls, rock slope protection and downstream energy dissipators. Refer to FHWA (2005, 2012) and FHWA (1983) for specific analysis techniques and design procedures.

## **Appendix 7.1 References**

California Department of Transportation (1988). *Standard Specifications*. Sacramento, CA.

Federal Highway Administration (1983). "Hydraulic Design of Energy Dissipators for Culverts and Channels." *Hydraulic Engineering Circular No. 14 (HEC-14)*. Washington, D.C.

Federal Highway Administration (1985). "Hydraulic Design of Highway Culverts." *Hydraulic Design Series No. 5 (HDS-5), FHWA-IP-85-15*. Washington, D.C.

Federal Highway Administration (1987). "HY8 Culvert Analysis Program Applications Guide." *Hydraulics Microcomputer Program HY8*. Washington, D.C.

GKY and Associates (1992). "HYDRAIN – Integrated Drainage Design Computer System." *Volume VI, HY8 – Culverts*. Springfield, VA.

Hydrologic Engineering Center (1975). "Water Surface Profiles." *International Hydrological Decade, V. 6*. USACE. Davis, CA.

Hydrologic Engineering Center (1990). "HEC-2 Water Surface Profiles, User's Manual." USACE. Davis, CA.

Psomas and Associates (1991). *El Dorado County Drainage Manual (Draft)*. Sacramento, CA.

U.S. Army Corps of Engineers (1991). "Hydraulic Design of Flood Control Channels." *Engineering Manual 1110-2-1601*. Office of the Chief of Engineers. Washington, D.C.

Water Environment Federation / American Society of Civil Engineers (1992). *Design and Construction of Urban Stormwater Management Systems*. New York, NY.

*See Appendix 7.1.1 for updated references*

### **Appendix 7.1.1 Updated References**

Listed below are the updated versions of select references for this section or references that were absent from the original *Drainage Manual*. If an updated version was not available, the original version should be referenced.

California Department of Transportation (2018). *Highway Design Manual*. Sacramento, CA.

California Department of Transportation (2018). *Standard Specifications*. Sacramento, CA.

Federal Highway Administration (2005). "Hydraulic Design of Highway Culverts." *Hydraulic Design Series No. 5 (HDS-5), FHWA-NHI-01-020*. Washington, D.C.

Federal Highway Administration (2006). "Hydraulic Design of Energy Dissipators for Culverts and Channels." *Hydraulic Engineering Circular No. 14 (HEC-14)*. Fairfax, VA.

Federal Highway Administration (2012). "Hydraulic Design of Highway Culverts." *Hydraulic Design Series No. 5 (HDS-5), FHWA-HIF-12-026*. Washington, D.C.

GKY and Associates (1999). "HYDRAIN – Integrated Drainage Design Computer System; version 6.1." *FHWA-IF99-008*. Springfield, VA.

Hydrologic Engineering Center (1992). "HEC-2 Water Surface Profiles Program." USACE. Davis, CA.

Hydrologic Engineering Center (2018). *HEC-RAS: Hydrologic Modeling System HEC-HMS User's Manual*. USACE. Davis, CA

U.S. Army Corps of Engineers (1994). "Hydraulic Design of Flood Control Channels." *Engineering Manual 1110-2-1601*. Office of the Chief of Engineers, Washington, D.C.

## **Appendix 7.2 Culvert Hydraulics Nomograph Design Charts**

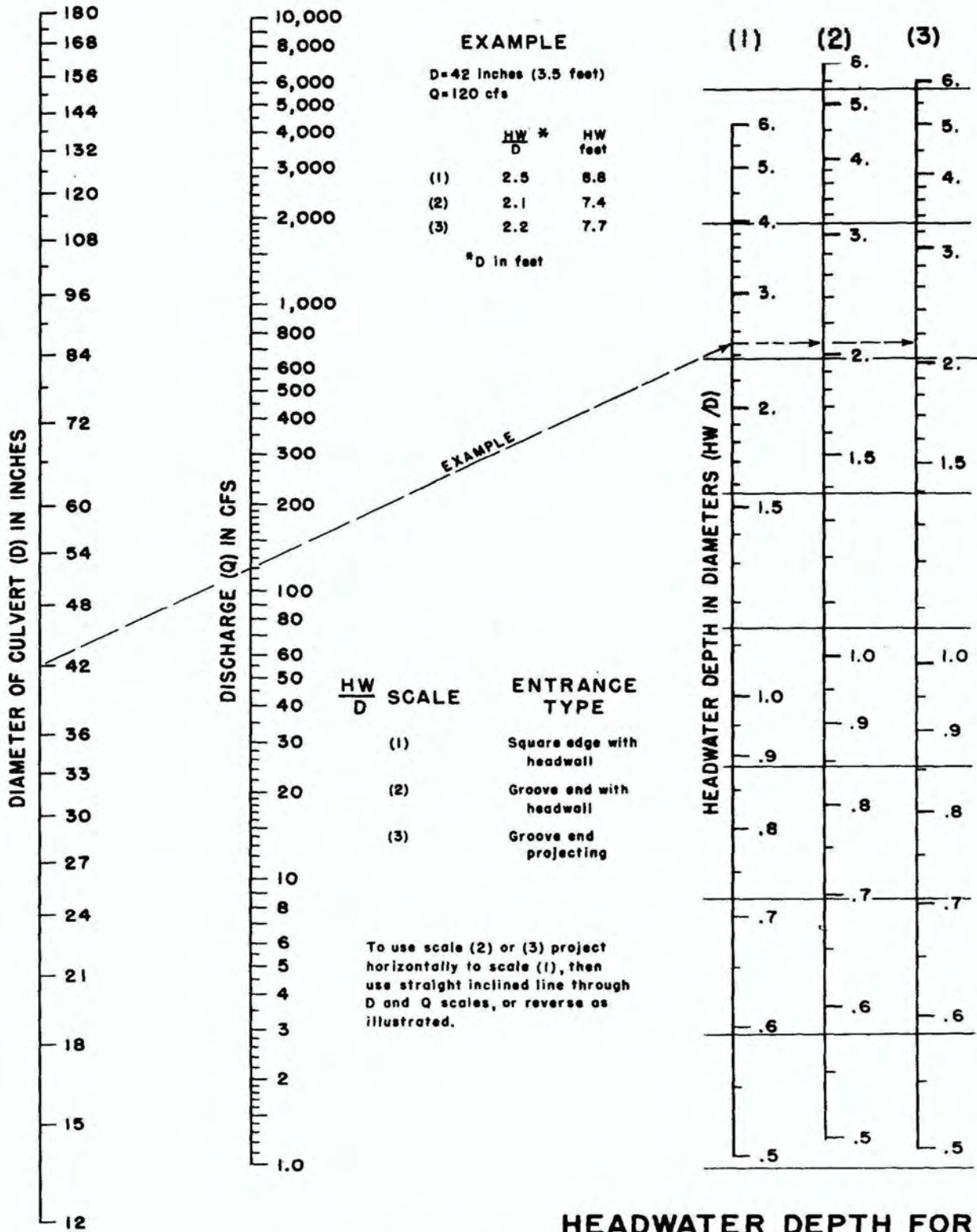
The following pages contain Charts 1-59 of “Hydraulic Design of Highway Culverts”, *HDS-5*, Federal Highway Administration, 2005 and 2012 (English Units).

For inlet control design charts: Draw a straight line from the correct pipe diameter through the correct design discharge ending at headwater scale No. 1 (or the leftmost scale). If the entrance type corresponds to Scale No. 1, read the corresponding value of dimensionless headwater depth. To determine the actual headwater depth, multiply this number by the appropriate culvert barrel dimension. If the inlet type is different than for Scale No. 1, project horizontally to the proper scale to determine the correct dimensionless headwater depth.

For outlet control design charts:

Determine the value of the entrance loss coefficient  $K_e$  from Table 7.2.2. Locate the curved scale that corresponds to the value of  $K_e$ . Locate the length of the culvert barrel on the appropriate curved scale. Draw a straight line from the correct length on the correct scale to the correct diameter on the second scale from the left. Then draw a straight line from the correct design discharge through the point where the previous line intersects the turning line. This line intersects the scale on the right giving the appropriate value of the headwater depth.

# CHART 1

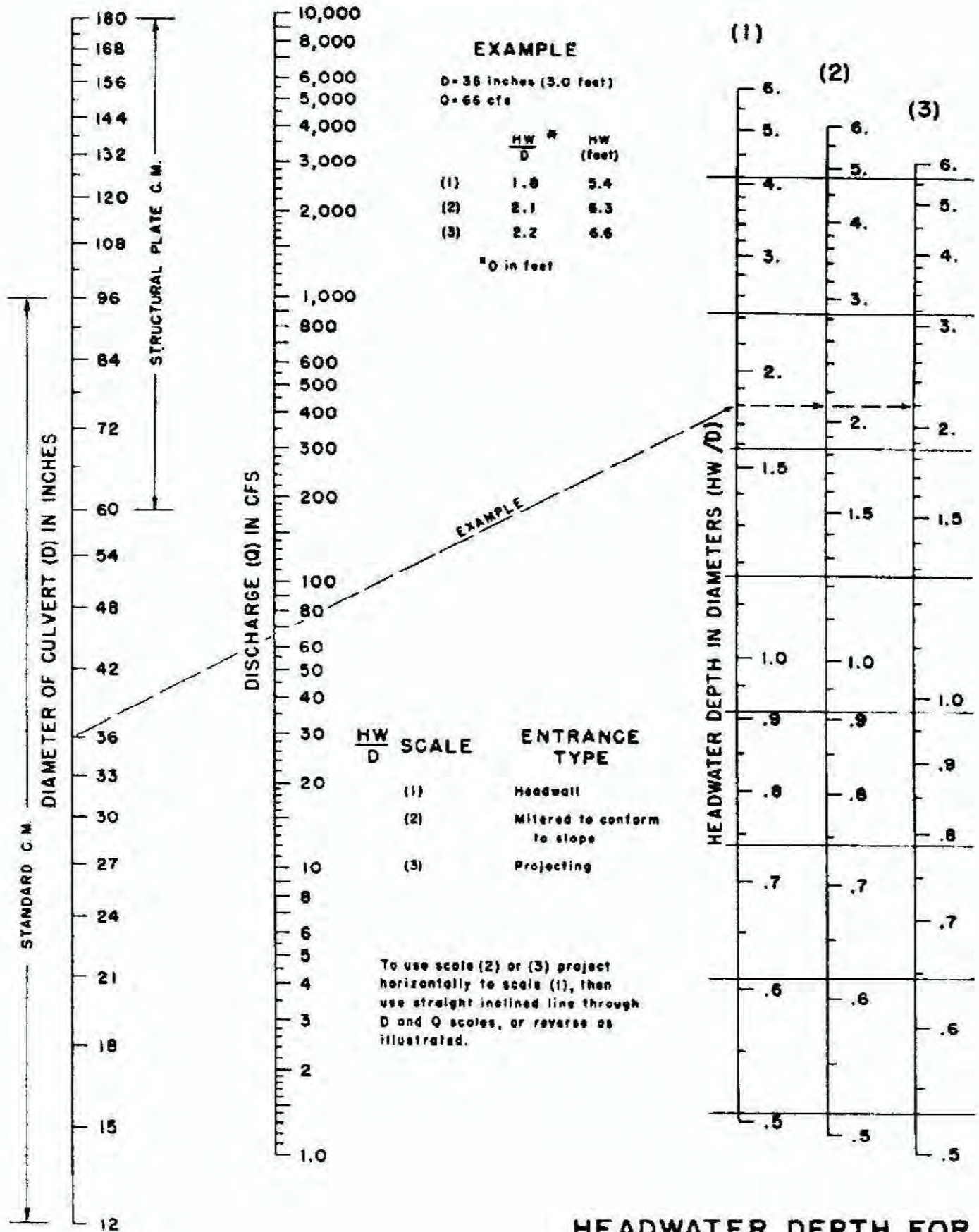


## HEADWATER DEPTH FOR CONCRETE PIPE CULVERTS WITH INLET CONTROL

HEADWATER SCALES 2 & 3  
 REVISED MAY 1964

BUREAU OF PUBLIC ROADS JAN. 1963

# CHART 2

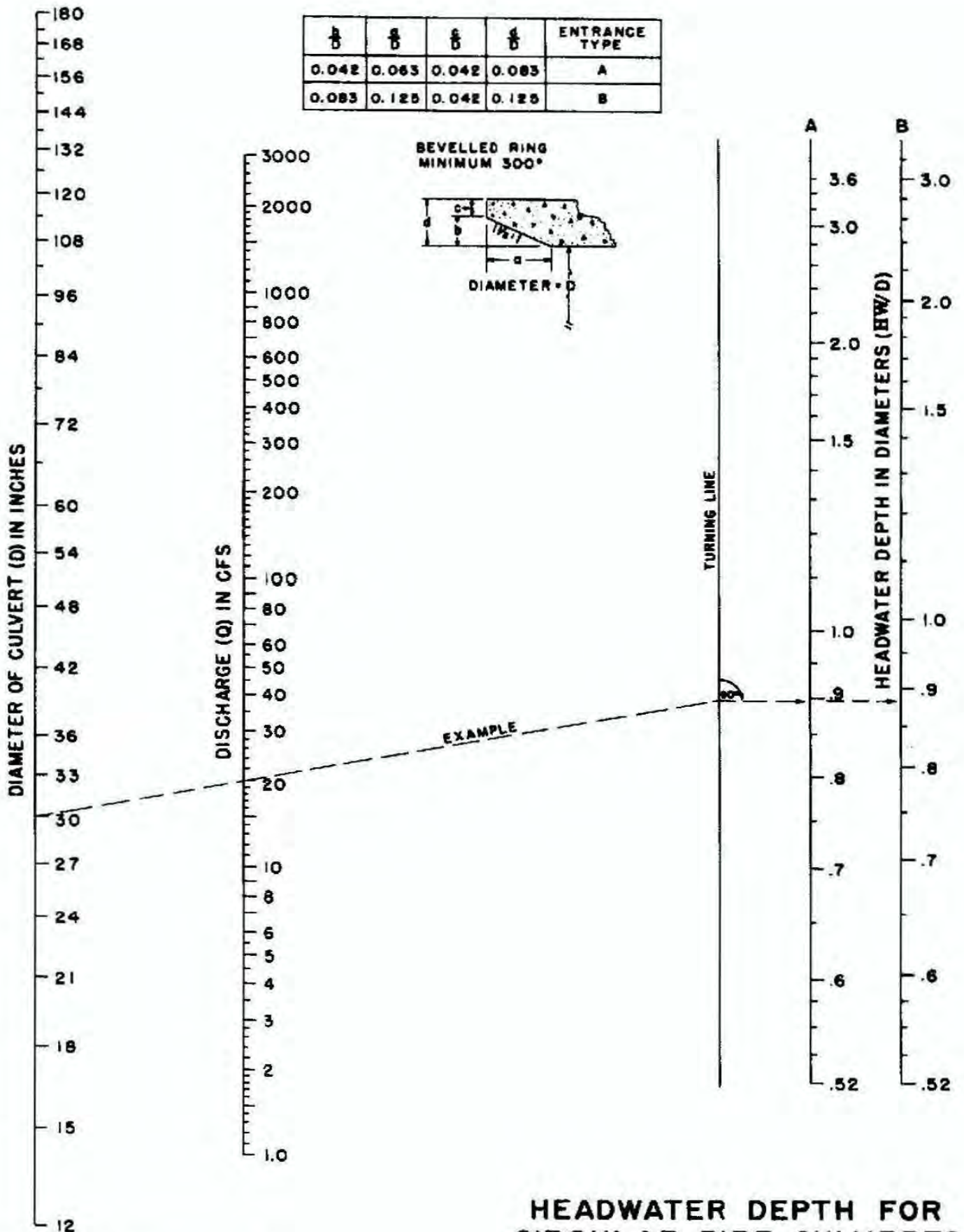


## HEADWATER DEPTH FOR C. M. PIPE CULVERTS WITH INLET CONTROL



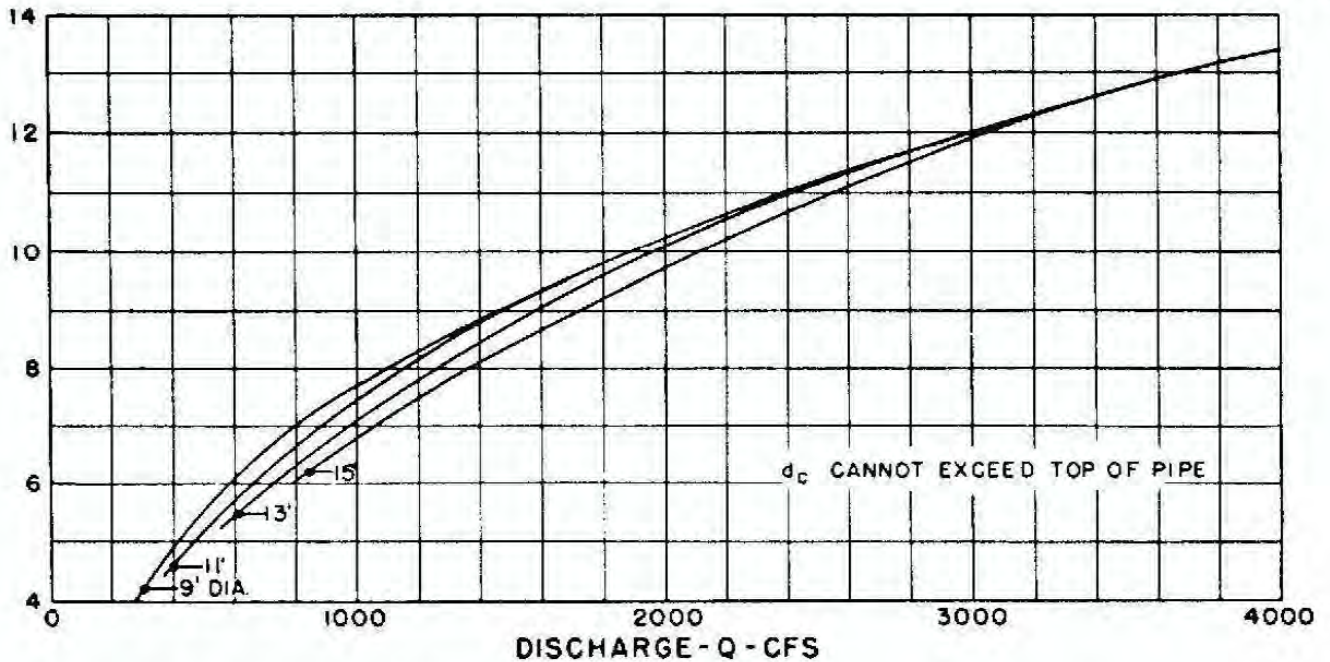
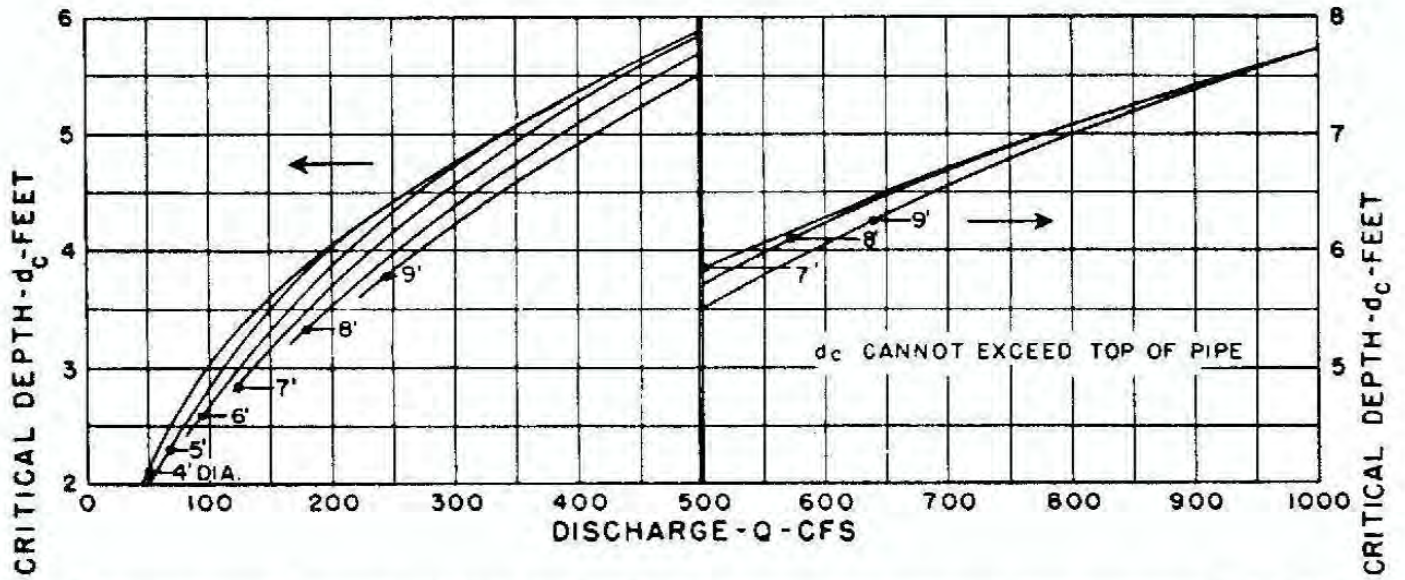
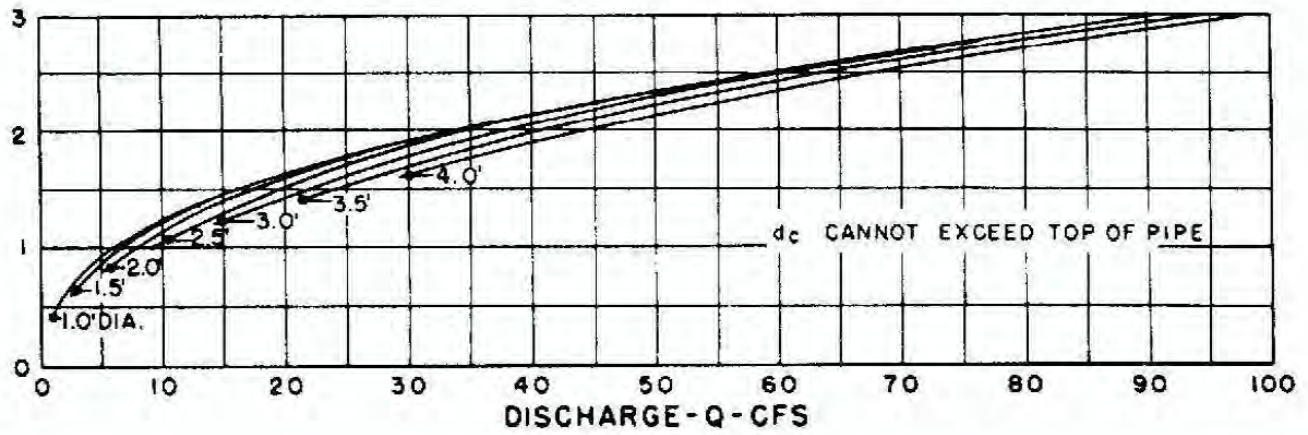
# CHART 3

| $\frac{h}{D}$ | $\frac{h}{D}$ | $\frac{h}{D}$ | $\frac{h}{D}$ | ENTRANCE TYPE |
|---------------|---------------|---------------|---------------|---------------|
| 0.042         | 0.063         | 0.042         | 0.083         | A             |
| 0.083         | 0.125         | 0.042         | 0.125         | B             |



## HEADWATER DEPTH FOR CIRCULAR PIPE CULVERTS WITH BEVELED RING INLET CONTROL

# CHART 4



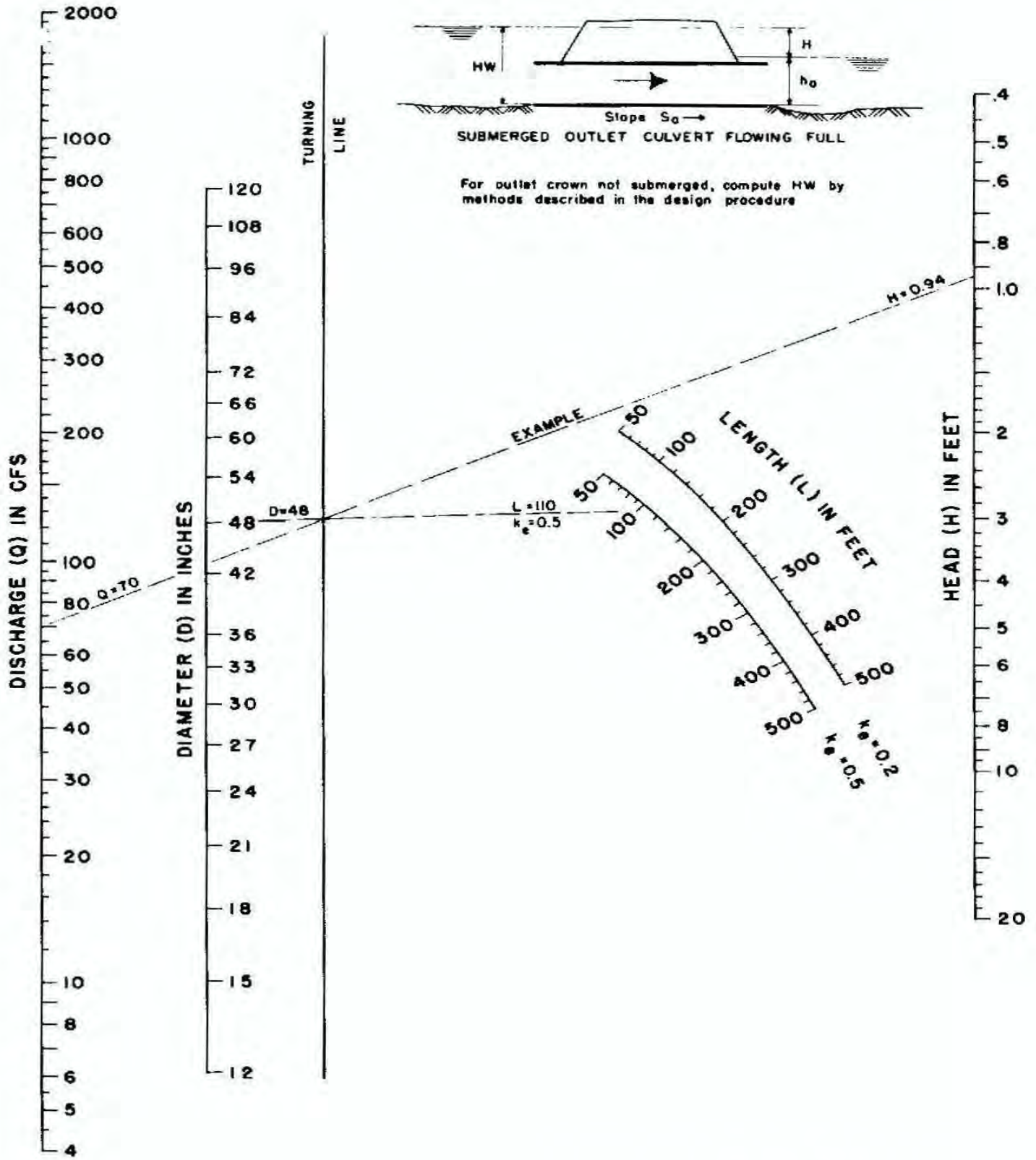
BUREAU OF PUBLIC ROADS

JAN. 1964

**CRITICAL DEPTH  
CIRCULAR PIPE**

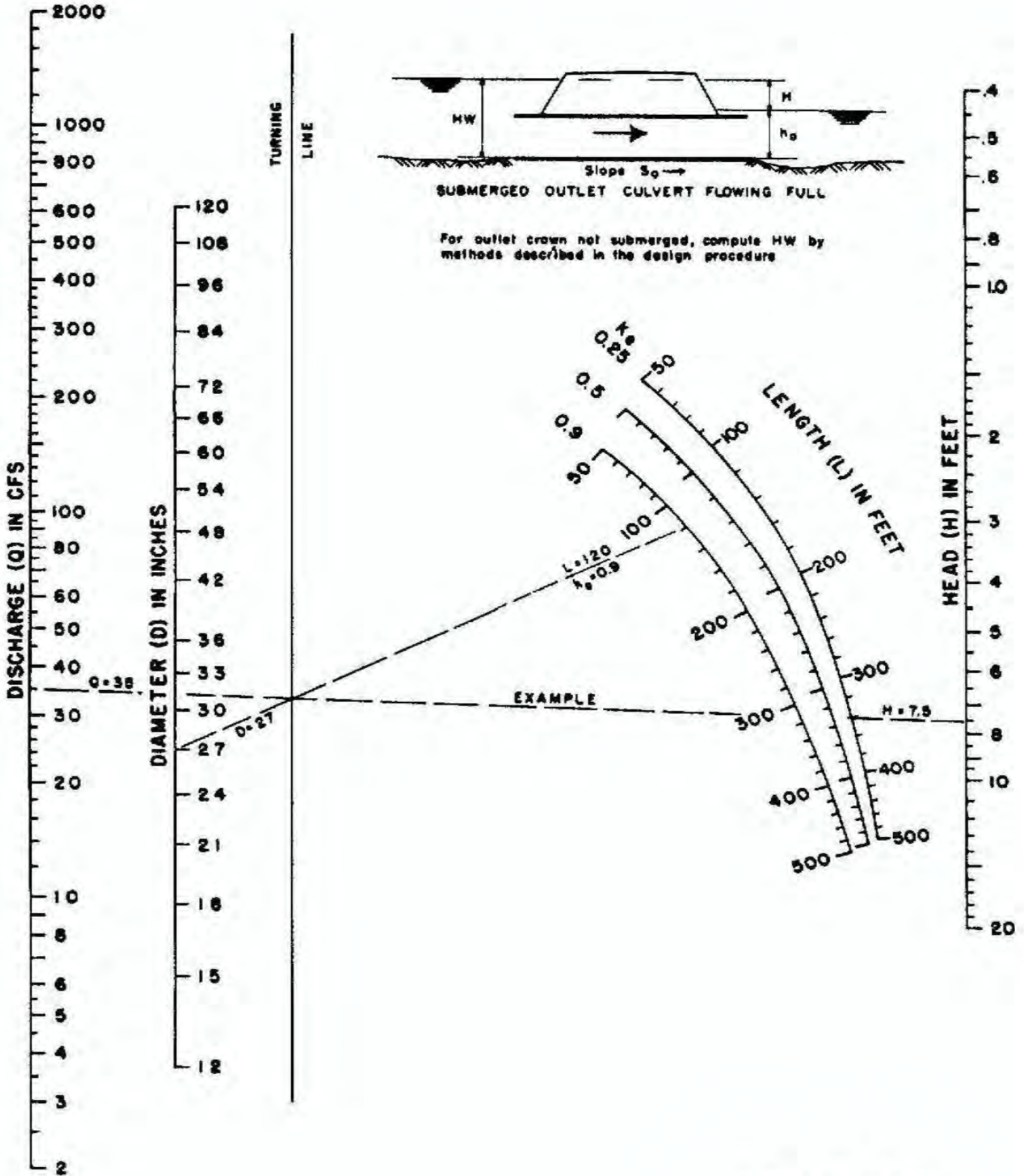


# CHART 5



**HEAD FOR  
CONCRETE PIPE CULVERTS  
FLOWING FULL  
 $n = 0.012$**

# CHART 6

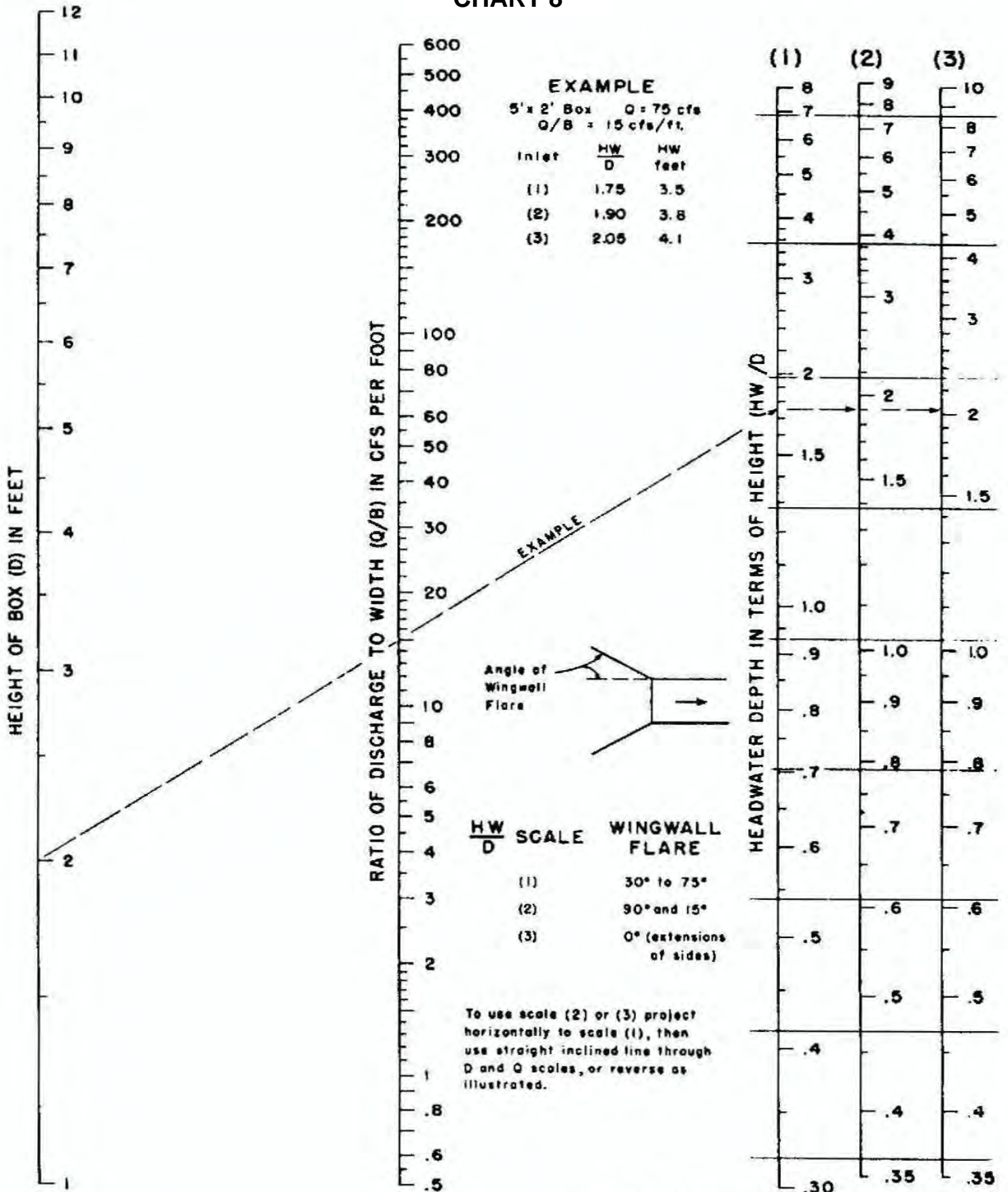


**HEAD FOR  
STANDARD  
C. M. PIPE CULVERTS  
FLOWING FULL  
 $n = 0.024$**





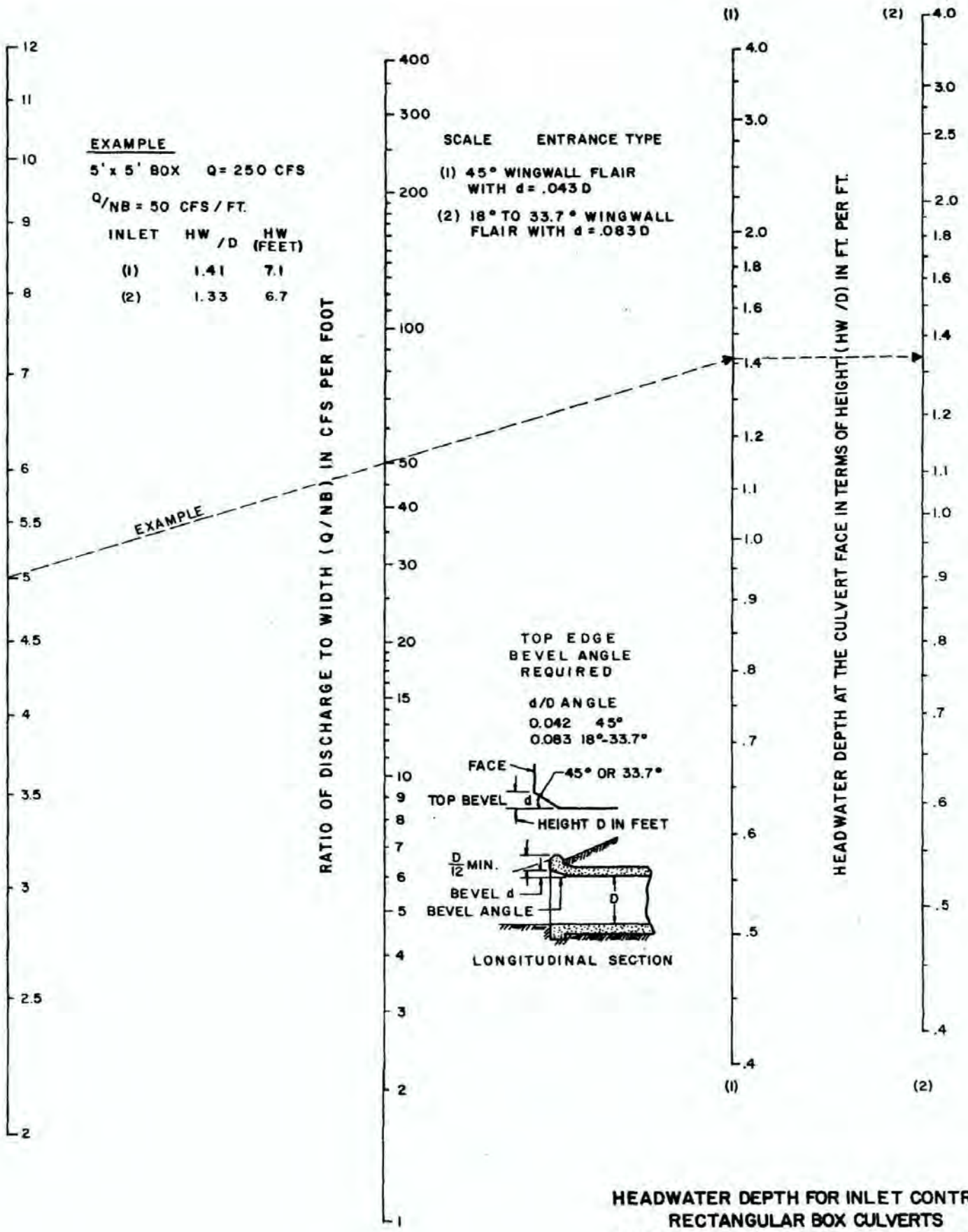
# CHART 8



## HEADWATER DEPTH FOR BOX CULVERTS WITH INLET CONTROL



# CHART 9



# CHART 10

## EXAMPLE

B=7 FT. D=5 FT. Q=500 CFS Q/NB = 71.5

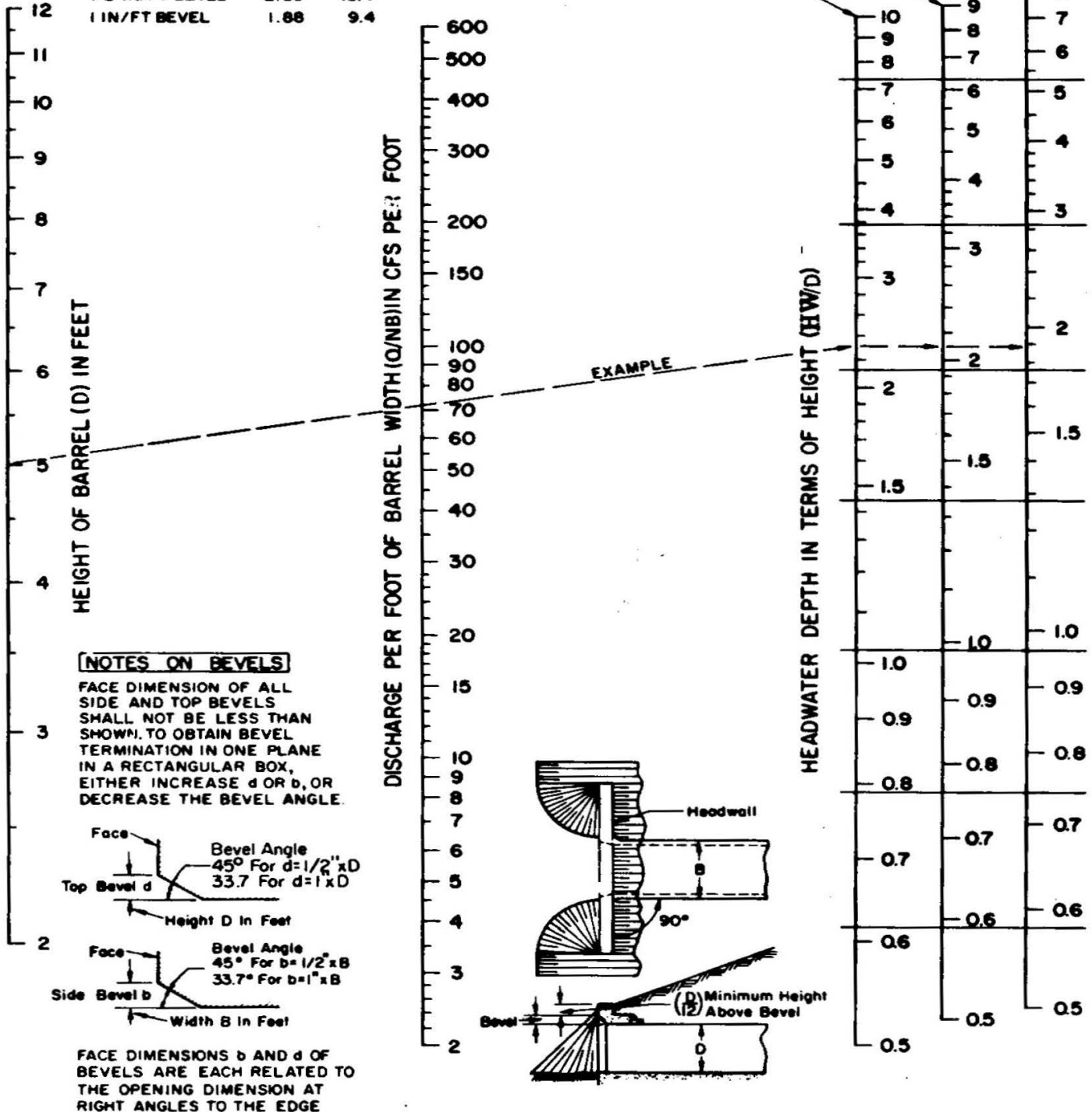
| ALL EDGES       | HW<br>D | HW<br>feet |
|-----------------|---------|------------|
| CHAMFER 3/4"    | 2.31    | 11.5       |
| 1/2 IN/FT BEVEL | 2.09    | 10.4       |
| 1 IN/FT BEVEL   | 1.88    | 9.4        |

INLET FACE—ALL EDGES:

1 IN/FT. BEVELS 33.7° (1:1.5)

1/2 IN/FT BEVELS 45° (1:1)

3/4 INCH CHAMFERS



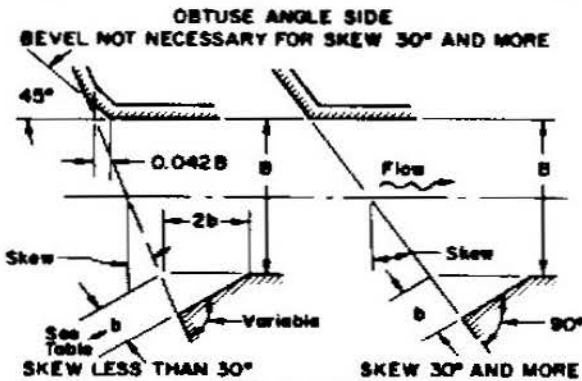
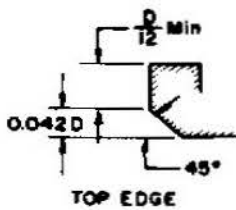
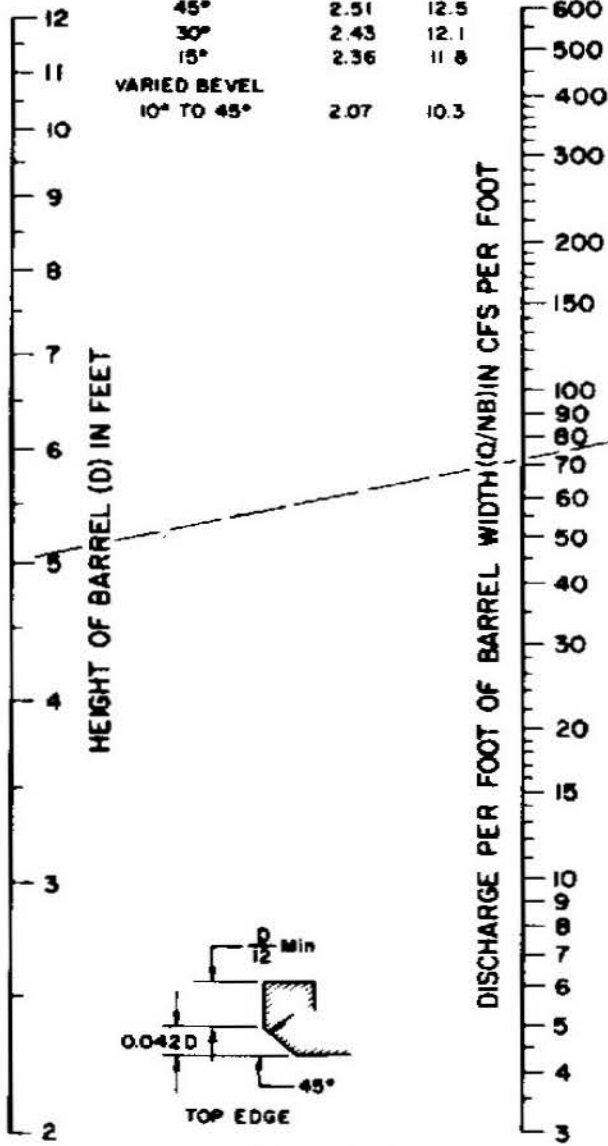
## HEADWATER DEPTH FOR INLET CONTROL RECTANGULAR BOX CULVERTS 90° HEADWALL CHAMFERED OR BEVELED INLET EDGES

# CHART 11

## EXAMPLE

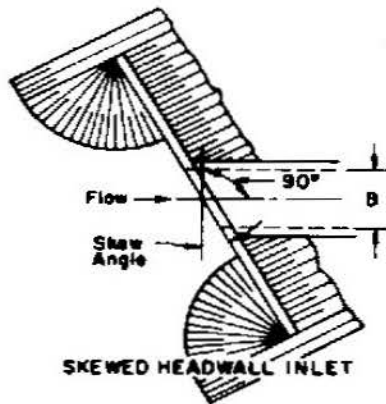
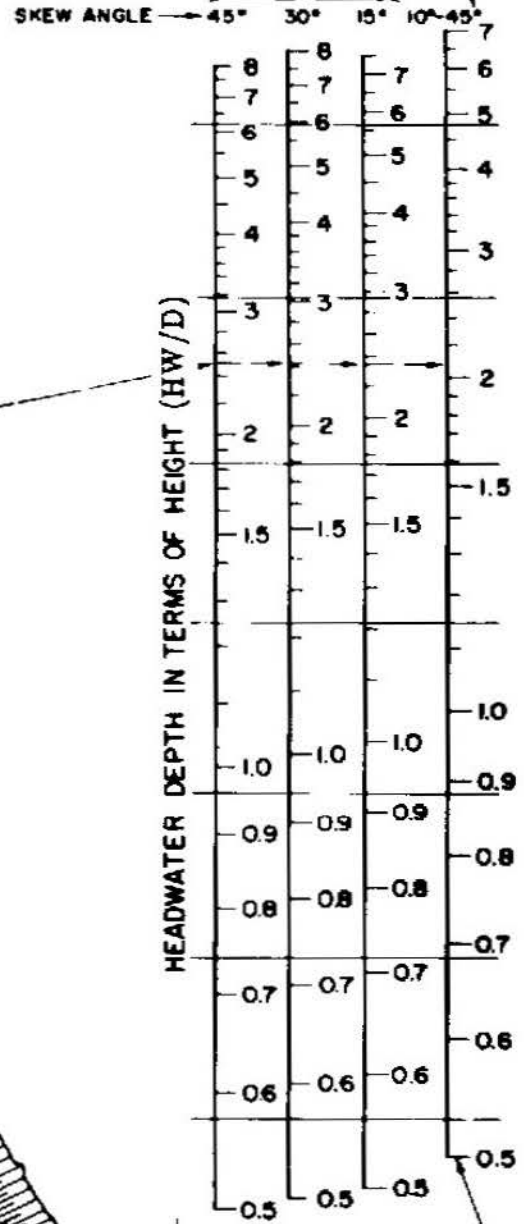
B=7 FT. D=5 FT. Q=500 CFS

| EDGE & SKEW  | HW<br>D | HW<br>feet |
|--------------|---------|------------|
| 3/4" CHAMFER |         |            |
| 45°          | 2.51    | 12.5       |
| 30°          | 2.43    | 12.1       |
| 15°          | 2.36    | 11.8       |
| VARIED BEVEL |         |            |
| 10° TO 45°   | 2.07    | 10.3       |



ACUTE ANGLE SIDE  
BEVELED INLET EDGES  
DESIGNED FOR SAME CAPACITY AT ANY SKEW

BEVELED EDGES - TOP AND SIDES  
3/4 INCH CHAMFER ALL EDGES



BEVELED EDGES  
AS DETAILED

| SKEW ANGLE | SIDE BEVEL b |
|------------|--------------|
| 10°        | 3/4" x B (H) |
| 15°        | 1" x B       |
| 22-1/2°    | 1-1/4" x B   |
| 30°        | 1-1/2" x B   |
| 37-1/2°    | 2" x B       |
| 45°        | 2-1/2" x B   |

## HEADWATER DEPTH FOR INLET CONTROL SINGLE BARREL BOX CULVERTS SKEWED HEADWALLS CHAMFERED OR BEVELED INLET EDGES



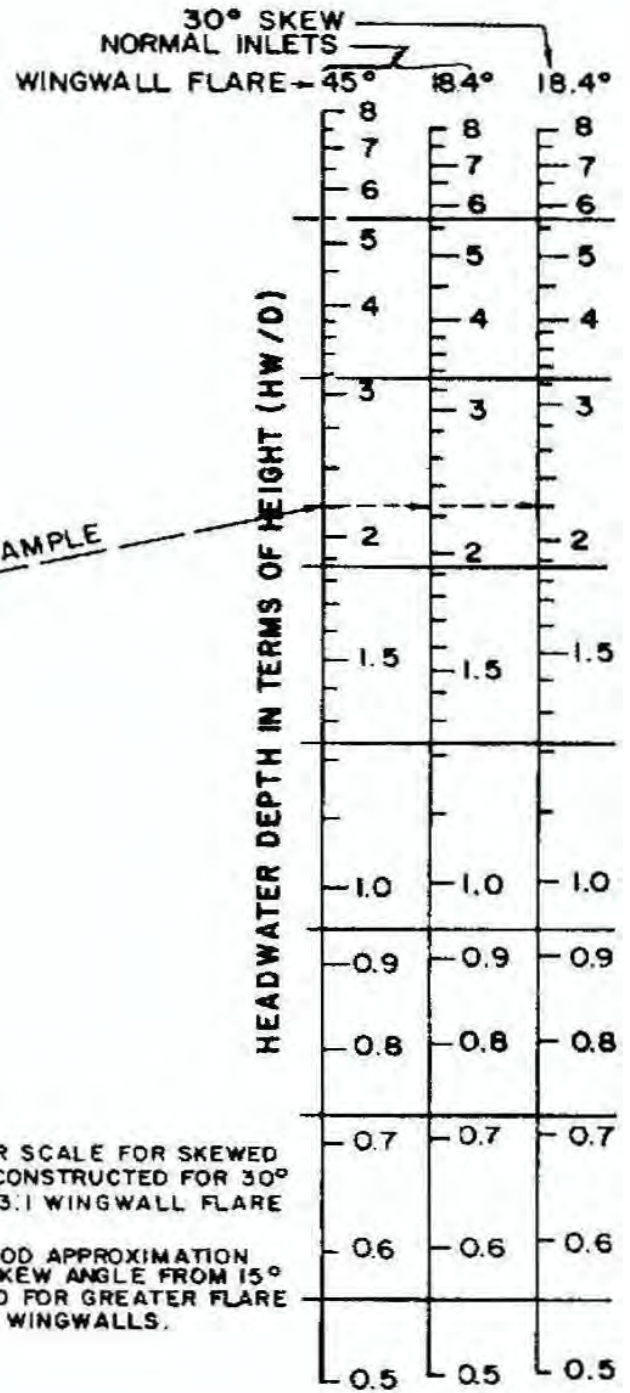
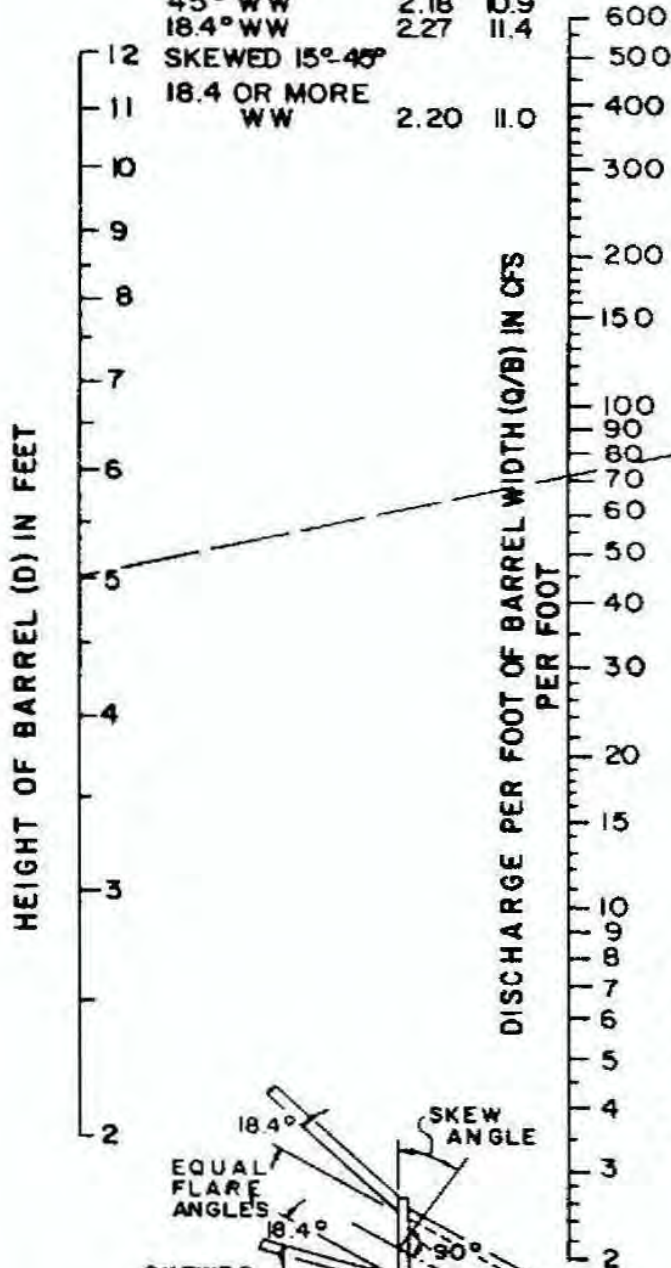
# CHART 12

## EXAMPLE

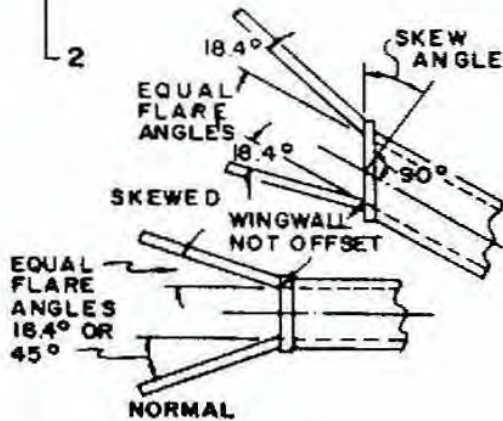
B = 7 FT. D = 5 FT. Q = 500 CFS

$$\frac{Q}{B} = 71.5$$

| INLET & WW         | HW<br>D | HW<br>FT |
|--------------------|---------|----------|
| NORMAL             |         |          |
| 45° WW             | 2.18    | 10.9     |
| 18.4° WW           | 2.27    | 11.4     |
| SKEWED 15°-45°     |         |          |
| 18.4 OR MORE<br>WW | 2.20    | 11.0     |



NOTE:  
HEADWATER SCALE FOR SKEWED INLETS IS CONSTRUCTED FOR 30° SKEW AND 3:1 WINGWALL FLARE (18.4°)  
ALSO A GOOD APPROXIMATION FOR ANY SKEW ANGLE FROM 15° TO 45° AND FOR GREATER FLARE ANGLES OF WINGWALLS.



WINGWALL INLETS

BUREAU OF PUBLIC ROADS  
OFFICE OF R. B. D. AUGUST 1968

HEADWATER DEPTH FOR INLET CONTROL  
RECTANGULAR BOX CULVERTS  
FLARED WINGWALLS  
NORMAL AND SKEWED INLETS  
3/4" CHAMFER AT TOP OF OPENING



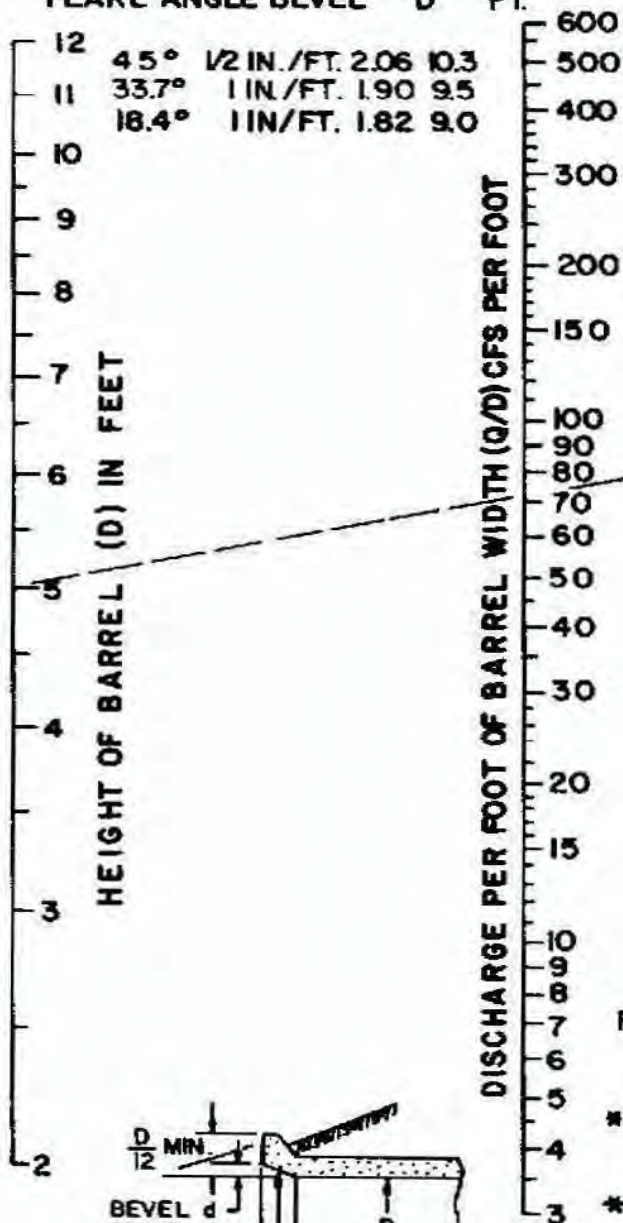
# CHART 13

## EXAMPLE

B = 7 FT. D = 5 FT. Q = 600 C.F.S

$$\frac{Q}{B} = 71.5$$

WINGWALL TOP EDGE FLARE ANGLE BEVEL  $\frac{HW}{D}$  HW FT.



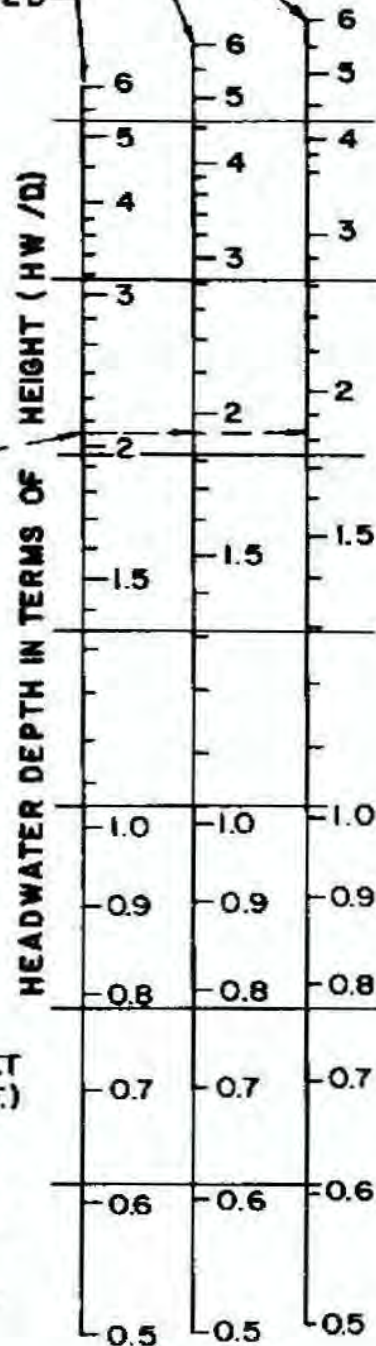
18.4° WW & d = 0.083D  
 33.7° WW & d = 0.083D  
 45° WW & d = 0.042D

TOP EDGE BEVEL ANGLE REQUIRED

| $\frac{d}{D}$ | ANGLE |
|---------------|-------|
| 0.042         | 45°   |
| 0.083         | 33.7° |

EXAMPLE

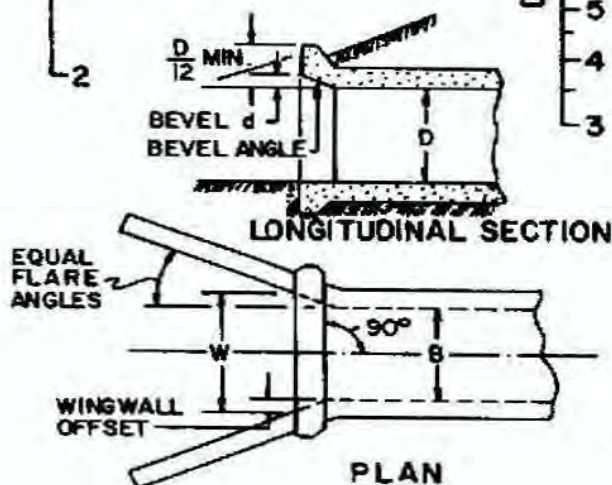
HEIGHT (HW/D) HEADWATER DEPTH IN TERMS OF



### WINGWALLS

| FLARE | ANGLE | MIN. OFFSET    |
|-------|-------|----------------|
| 1:1   | 45°   | 3/4" x B (FT.) |
| 1:1.5 | 33.7° | 1" x B         |
| * 1:2 | 26.6° | 1-1/4" x B     |
| 1:3   | 18.4° | 1-1/2" x B     |

\* USE 33.7° x 0.0083D TOP EDGE BEVEL AND READ HW ON SCALE FOR 18.4° WW

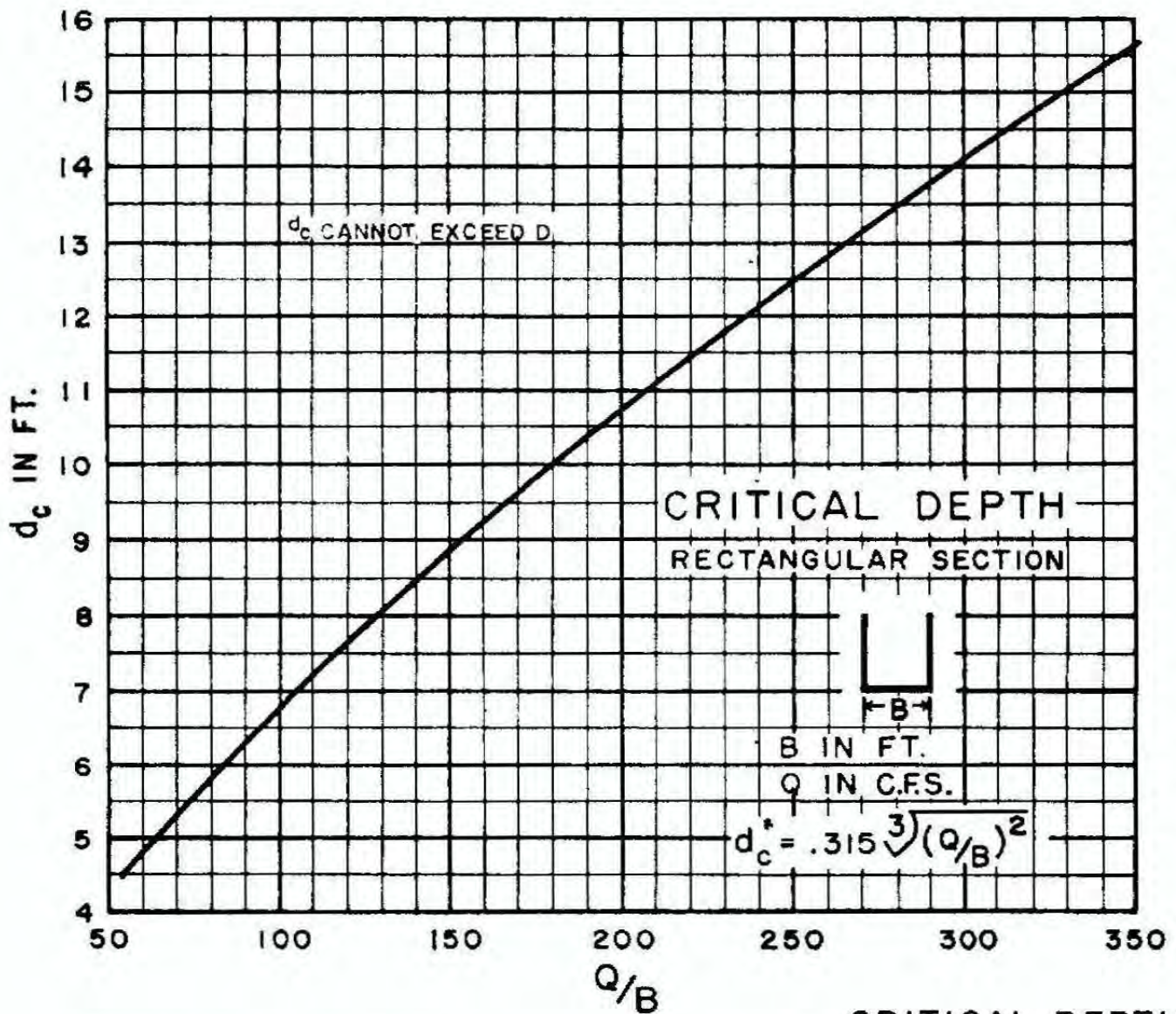
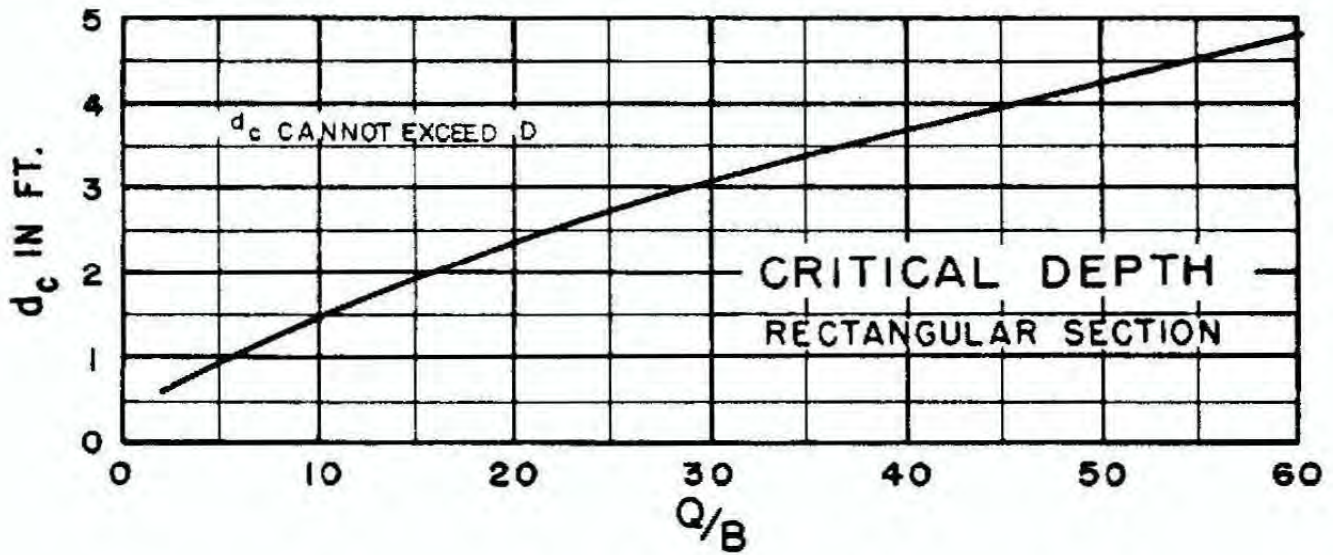


BUREAU OF PUBLIC ROADS  
 OFFICE OF R & D AUGUST 1968

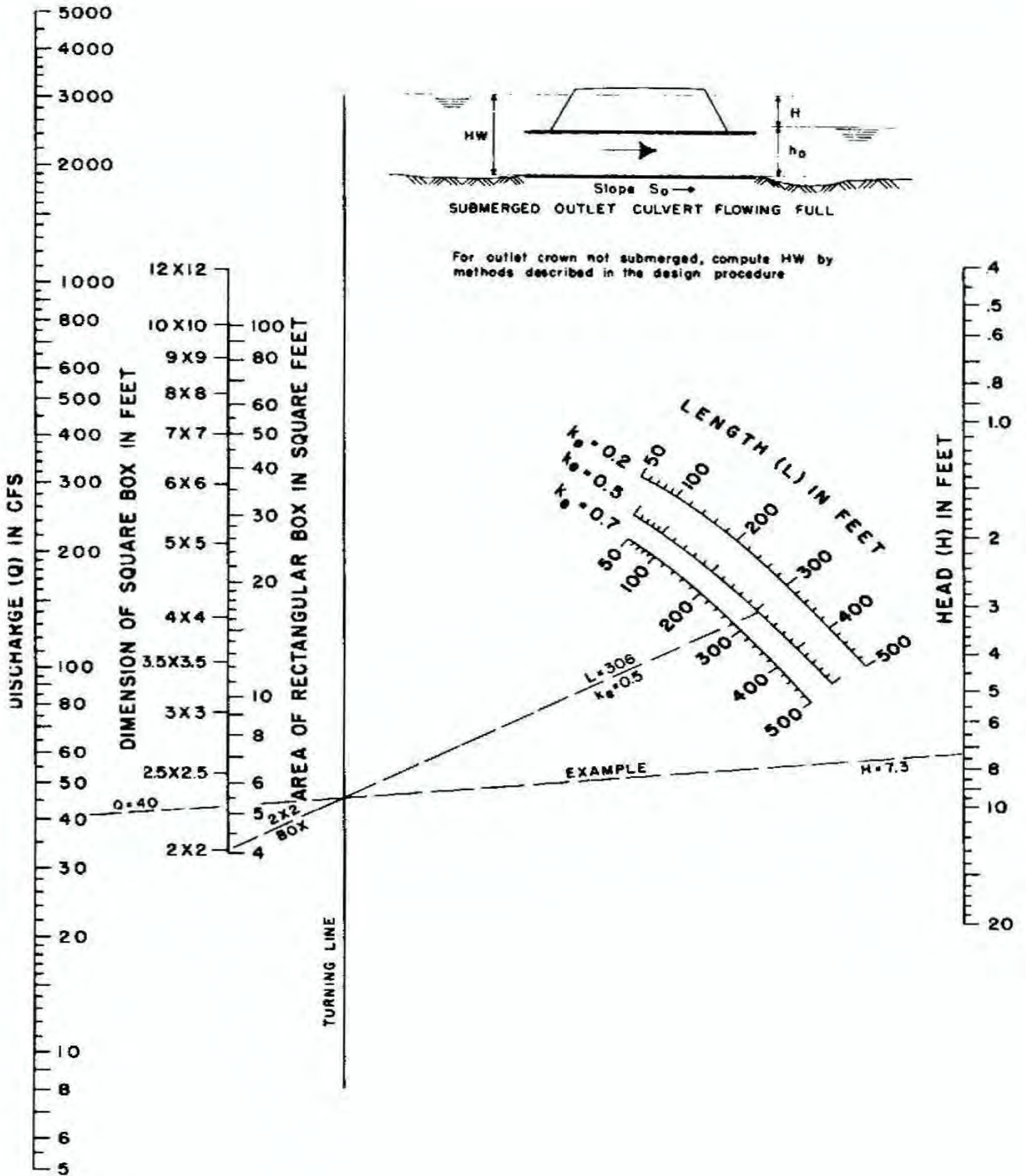
HEADWATER DEPTH FOR INLET CONTROL  
 RECTANGULAR BOX CULVERTS  
 OFFSET FLARED WINGWALLS  
 AND BEVELED EDGE AT TOP OF INLET



CHART 14

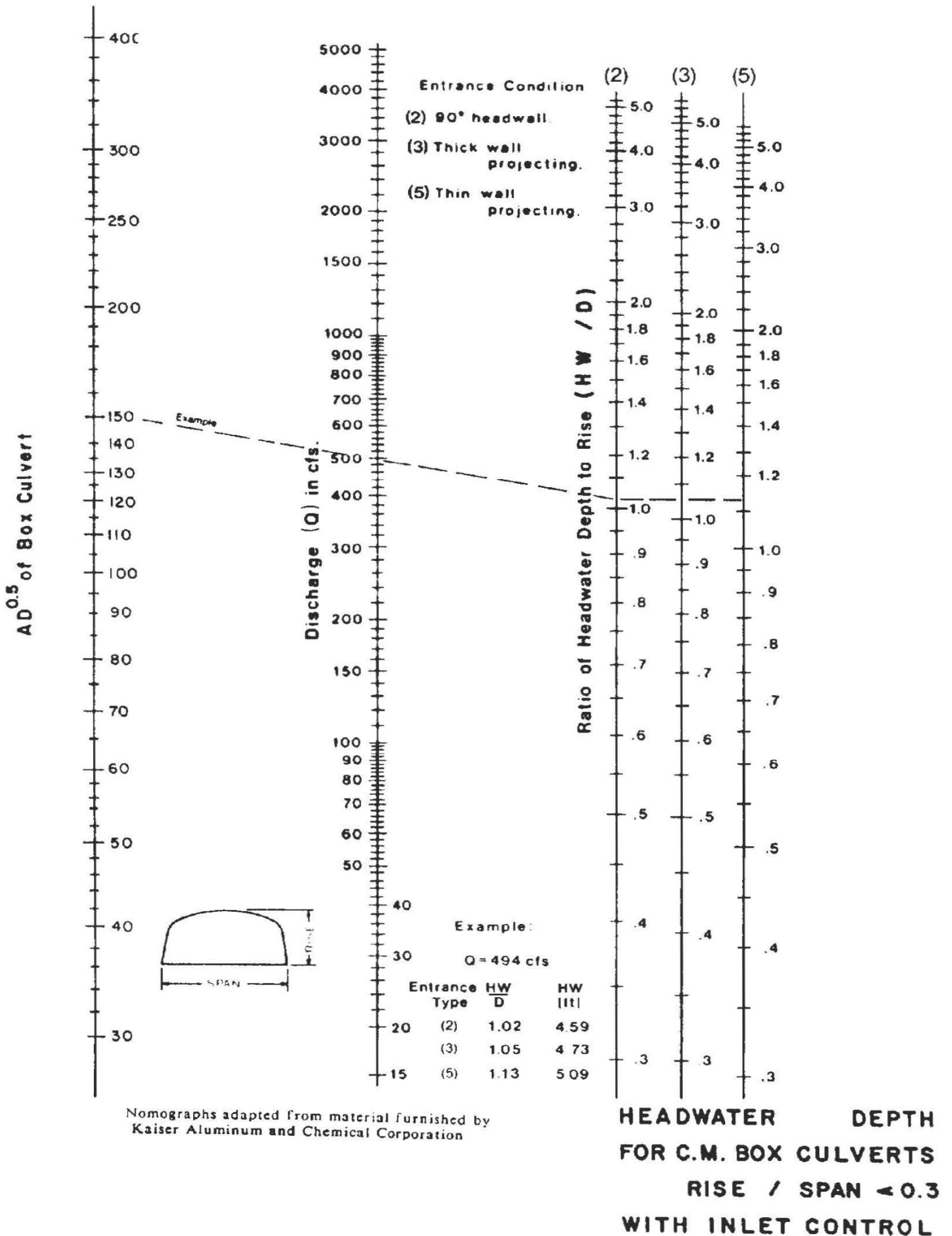


# CHART 15

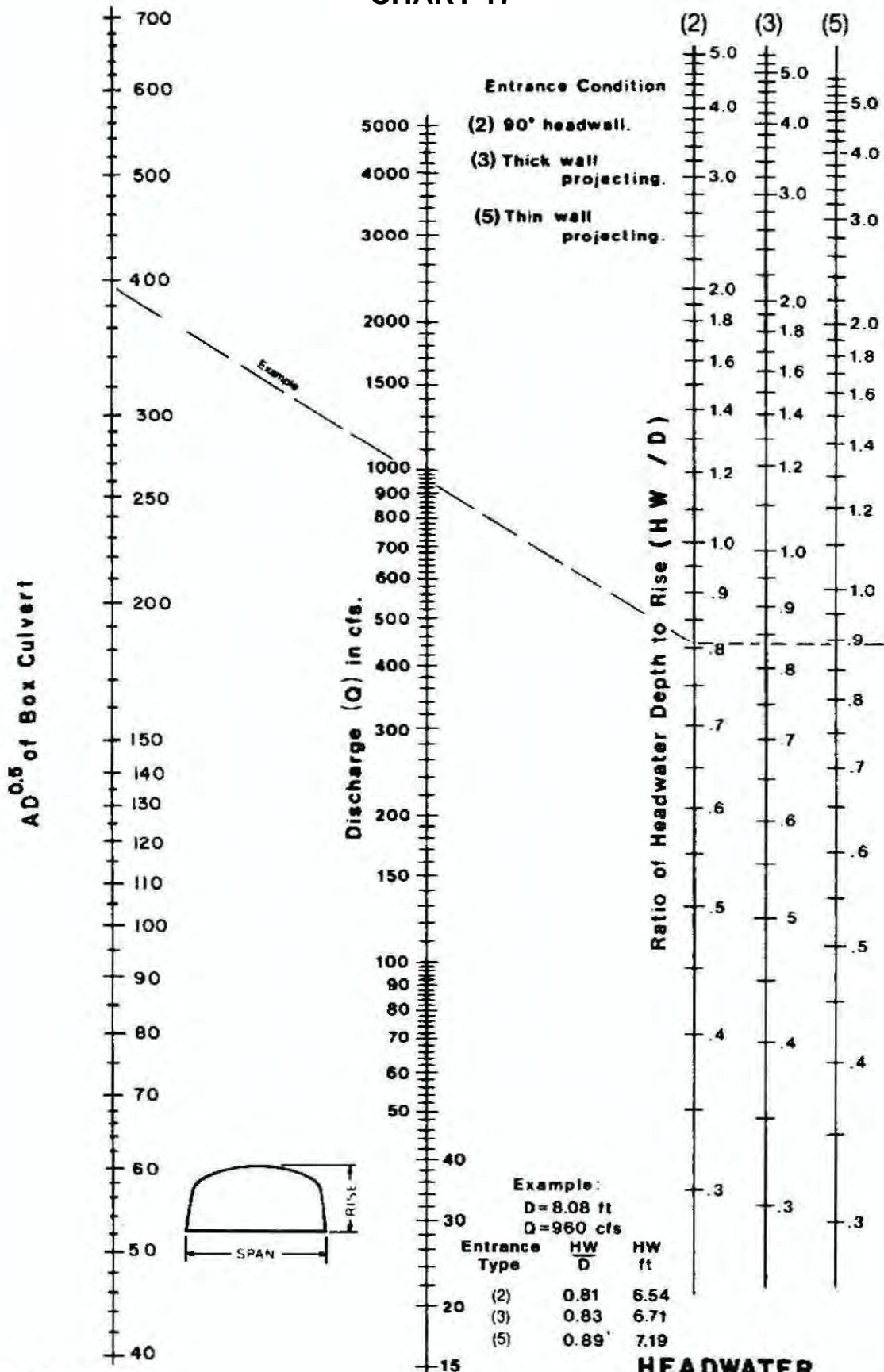




# CHART 16



# CHART 17

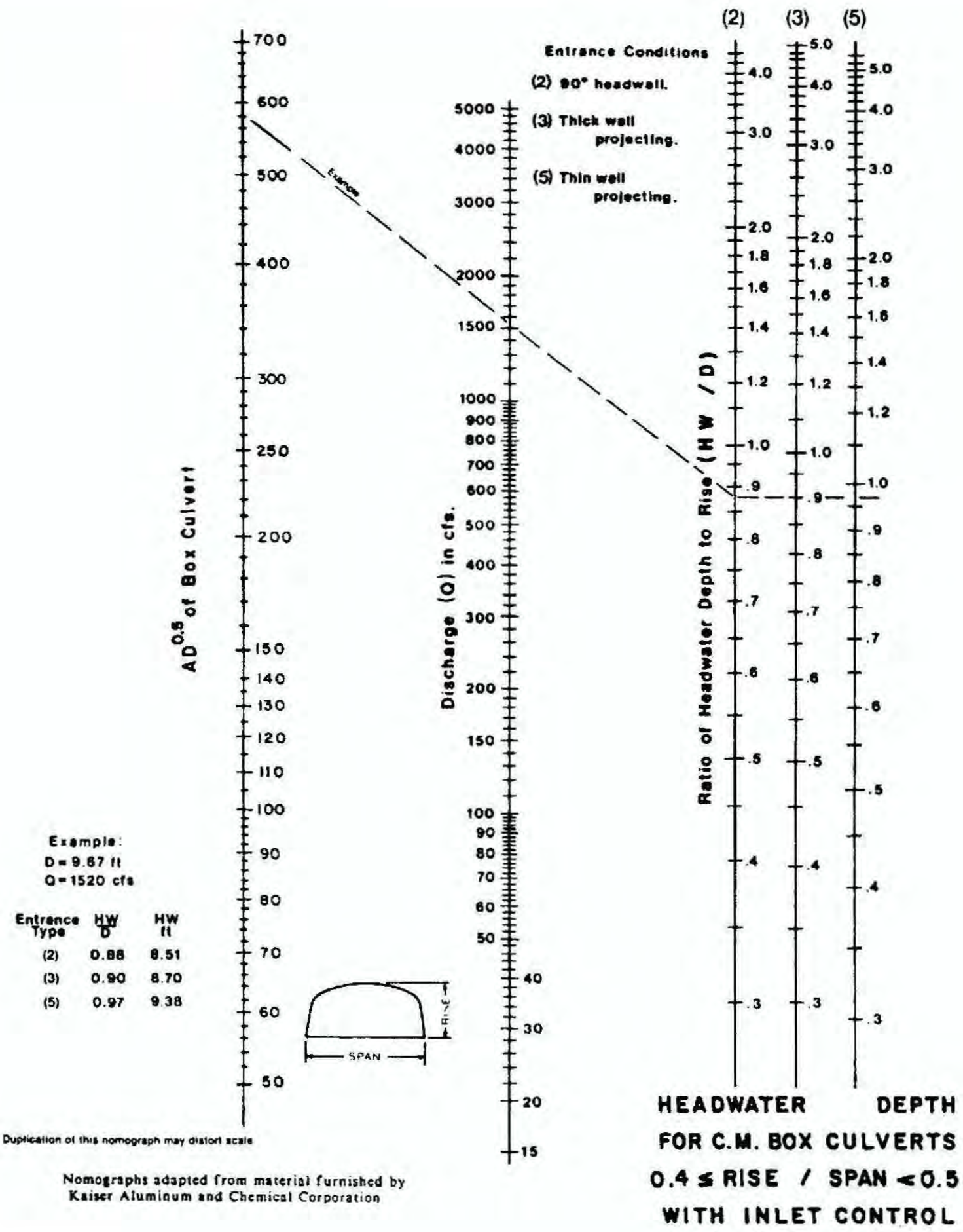


Duplication of this nomograph may distort scale

Nomographs adapted from material furnished by Kaiser Aluminum and Chemical Corporation

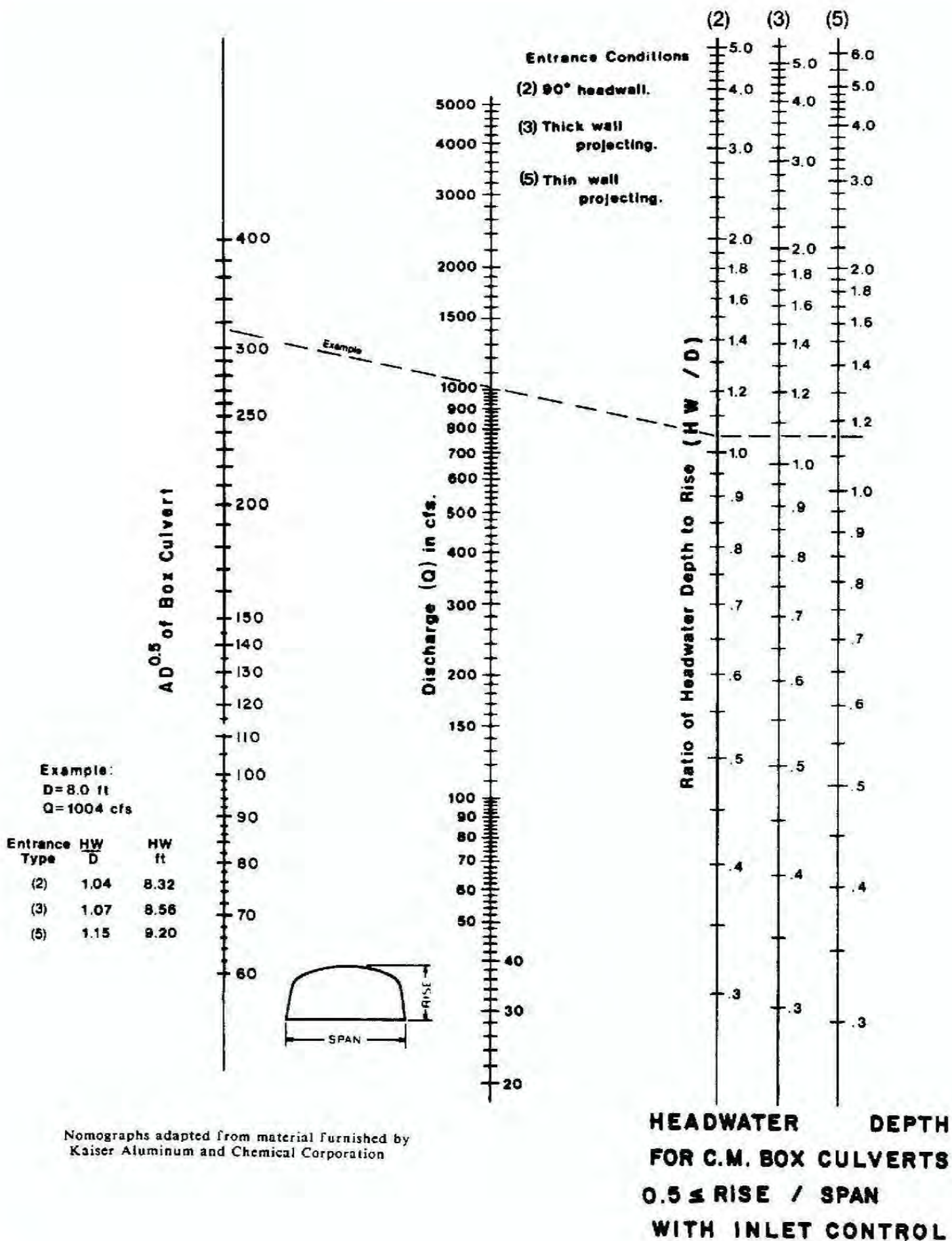
**HEADWATER DEPTH  
 FOR C.M. BOX CULVERTS  
 $0.3 \leq \text{RISE} / \text{SPAN} < 0.4$   
 WITH INLET CONTROL**

# CHART 18





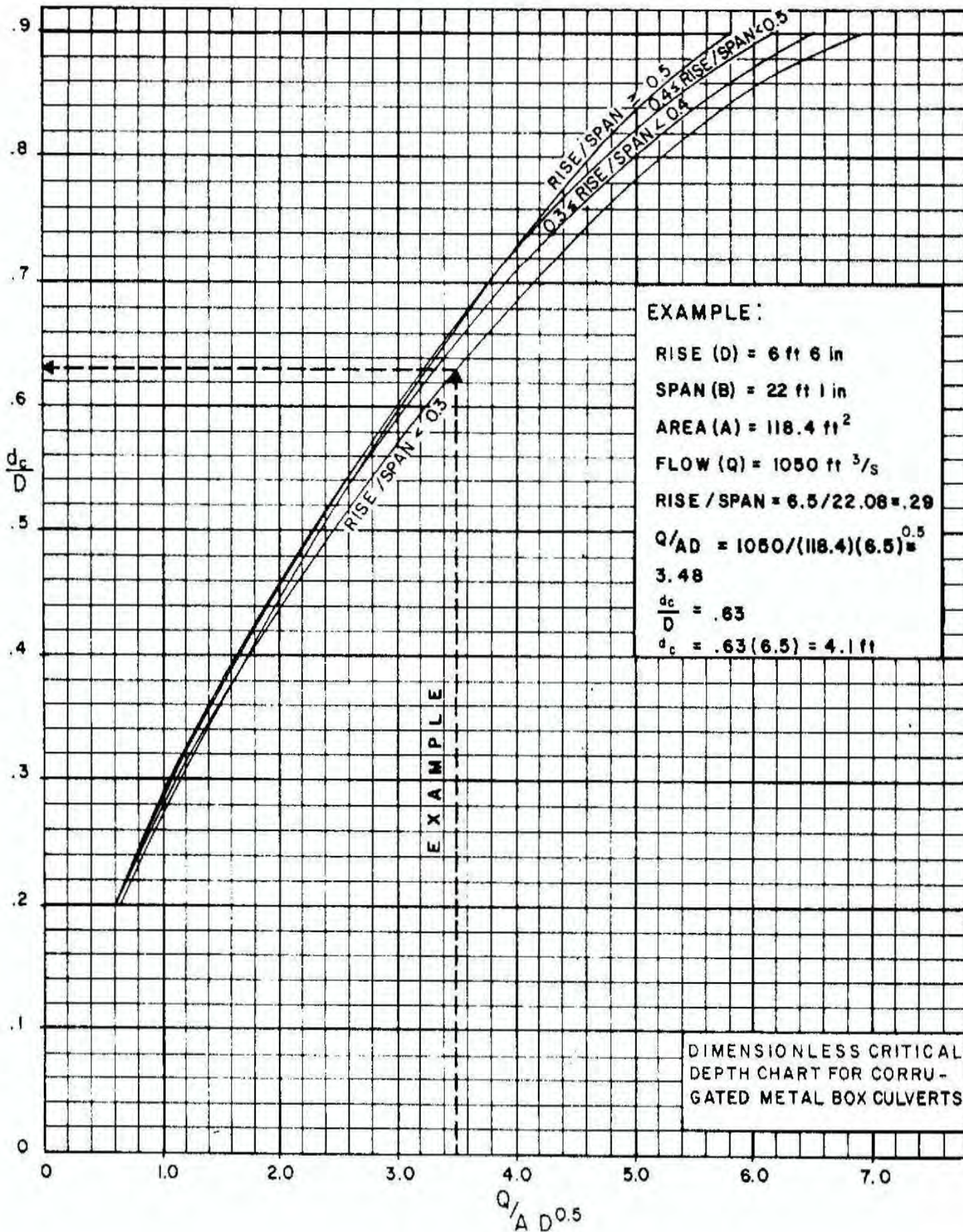
# CHART 19



Nomographs adapted from material furnished by Kaiser Aluminum and Chemical Corporation

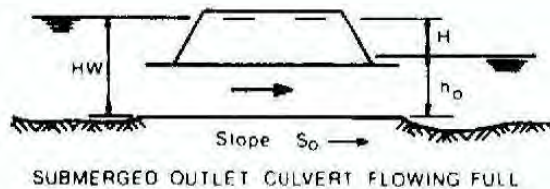
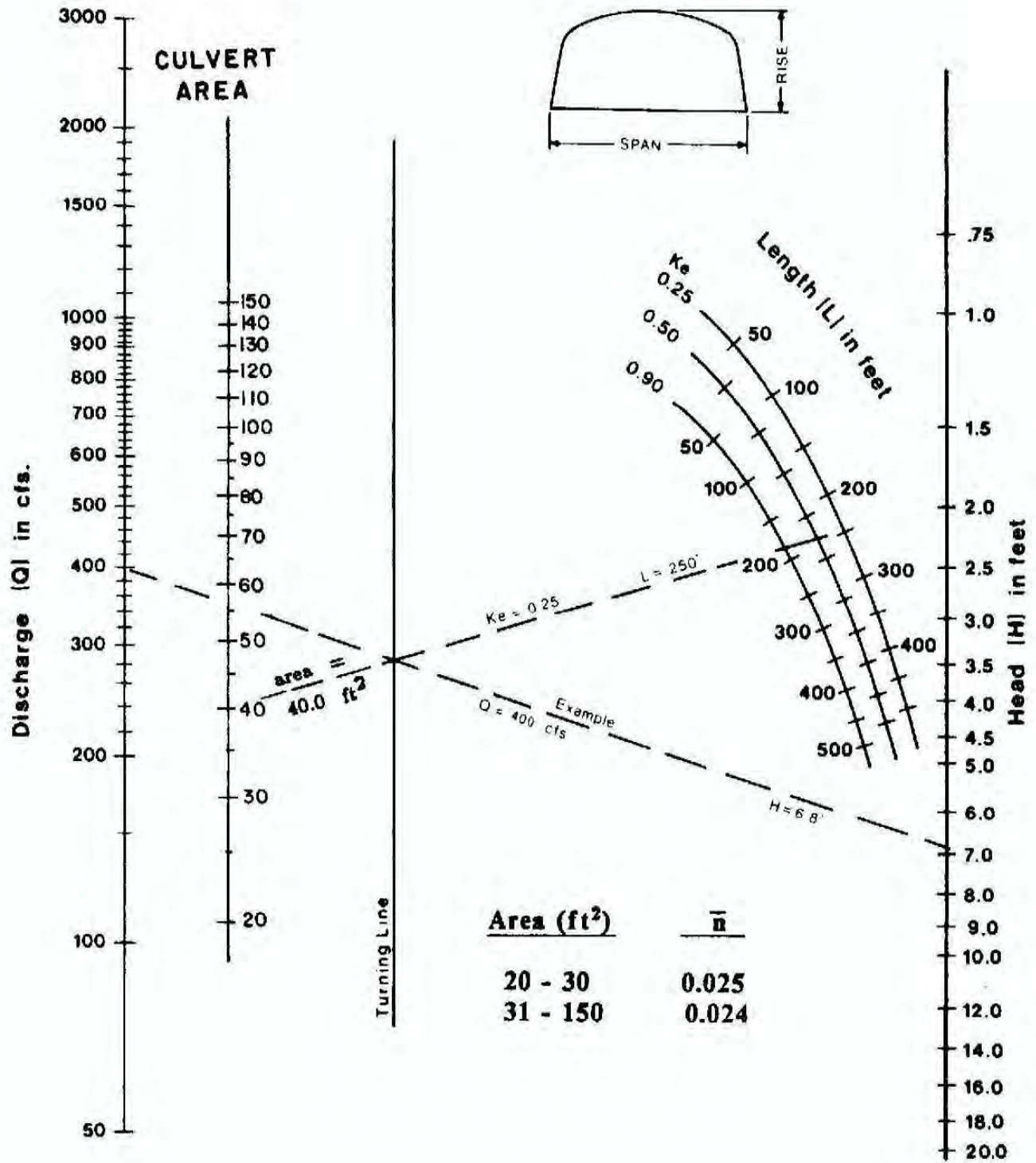


CHART 20





# CHART 21

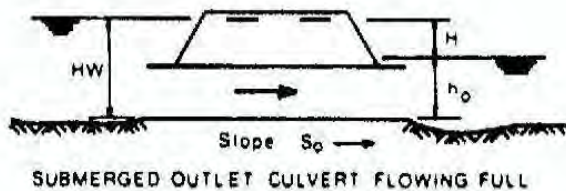
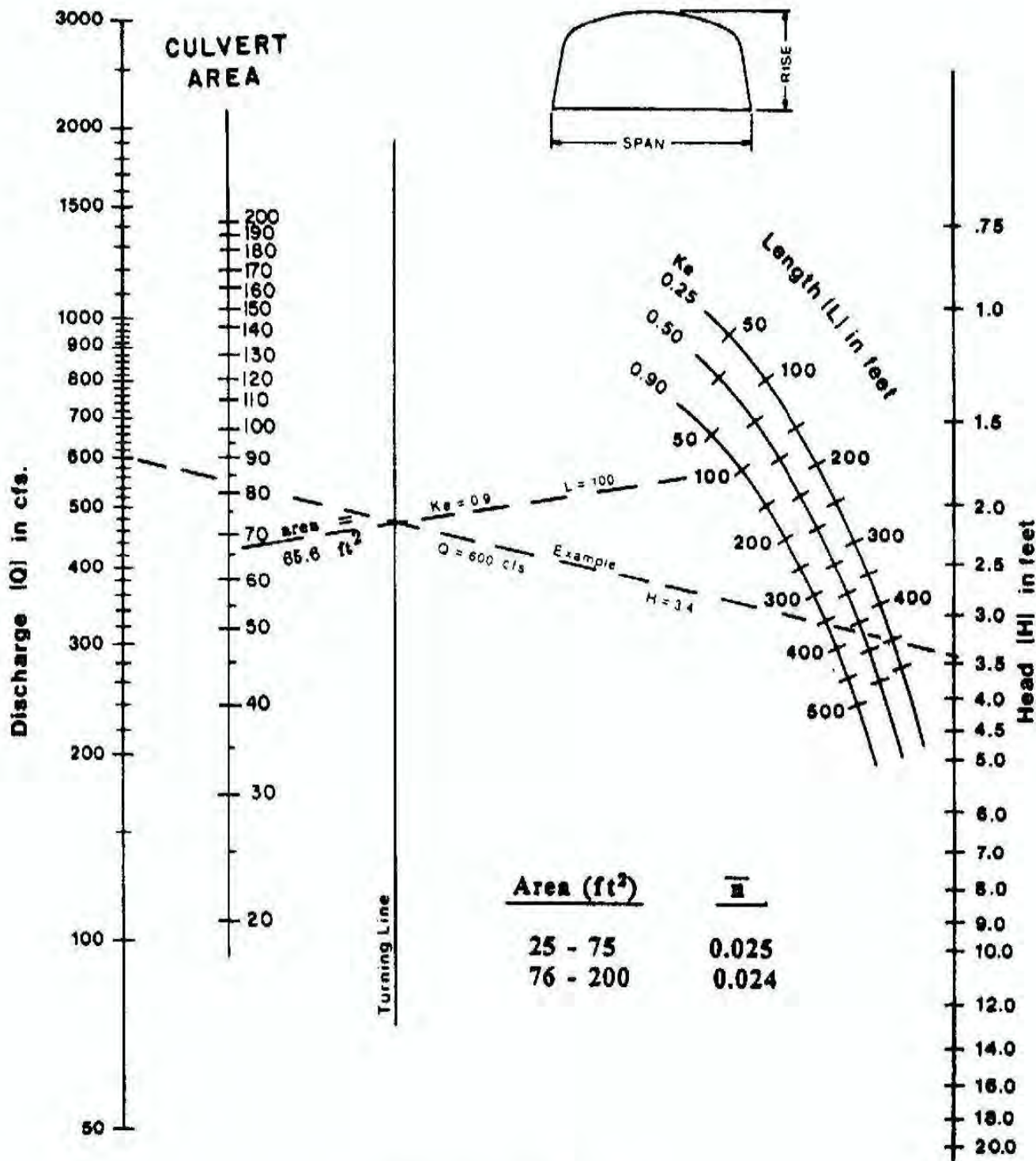


**HEAD FOR  
C. M. BOX CULVERTS  
FLOWING FULL  
CONCRETE BOTTOM  
RISE / SPAN < 0.3**

Nomographs adapted from material furnished by Kaiser Aluminum and Chemical Corporation

Duplication of this nomograph may distort scale

# CHART 22

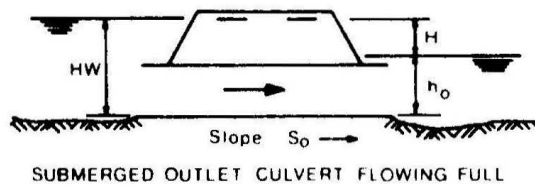
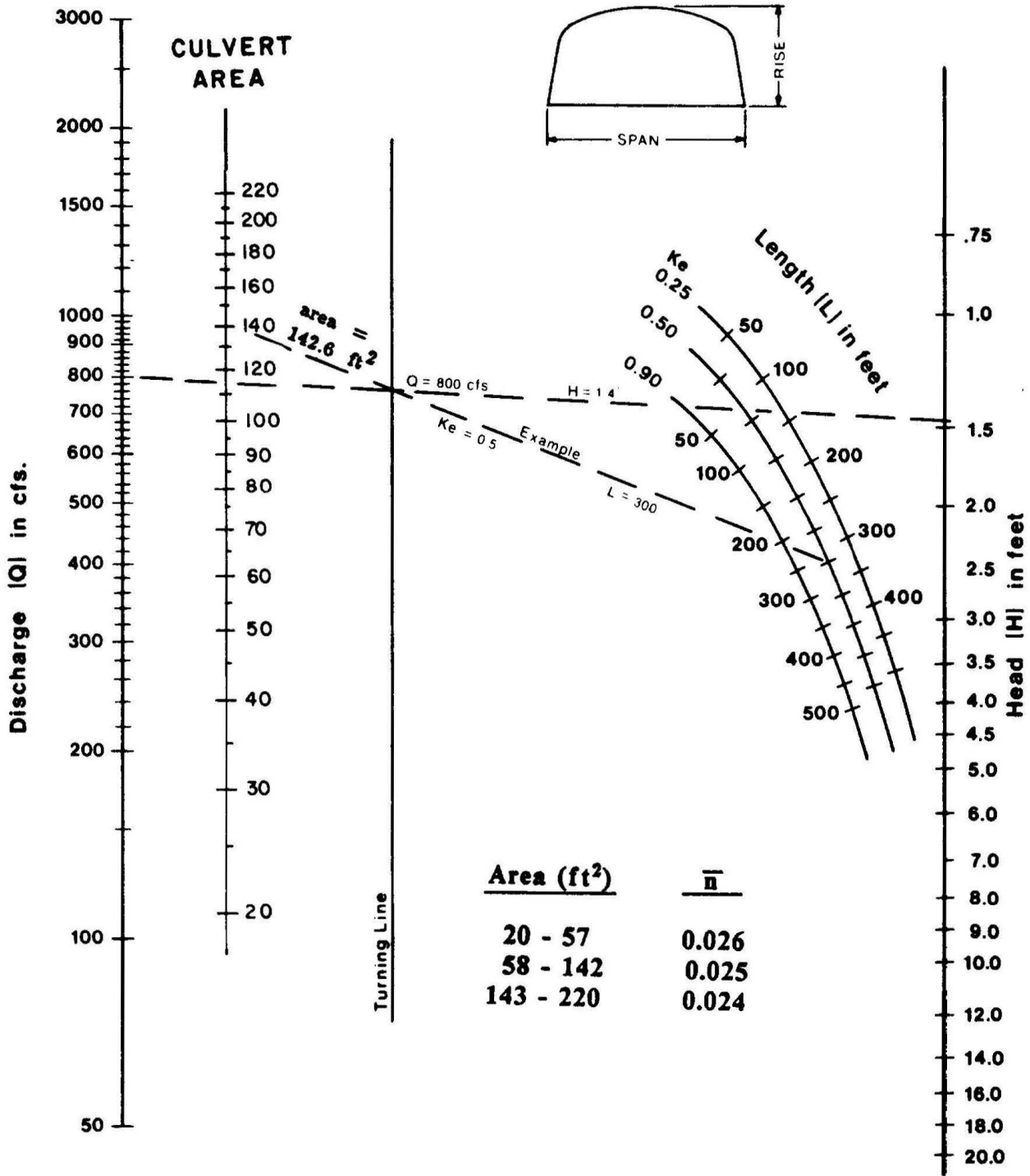


**HEAD FOR  
C. M. BOX CULVERTS  
FLOWING FULL  
CONCRETE BOTTOM  
0.3 ≤ RISE / SPAN < 0.4**

Nomographs adapted from material furnished by Kaiser Aluminum and Chemical Corporation

Duplication of this nomograph may distort scale

# CHART 23



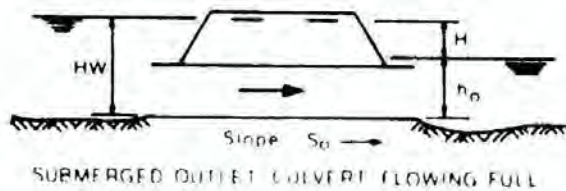
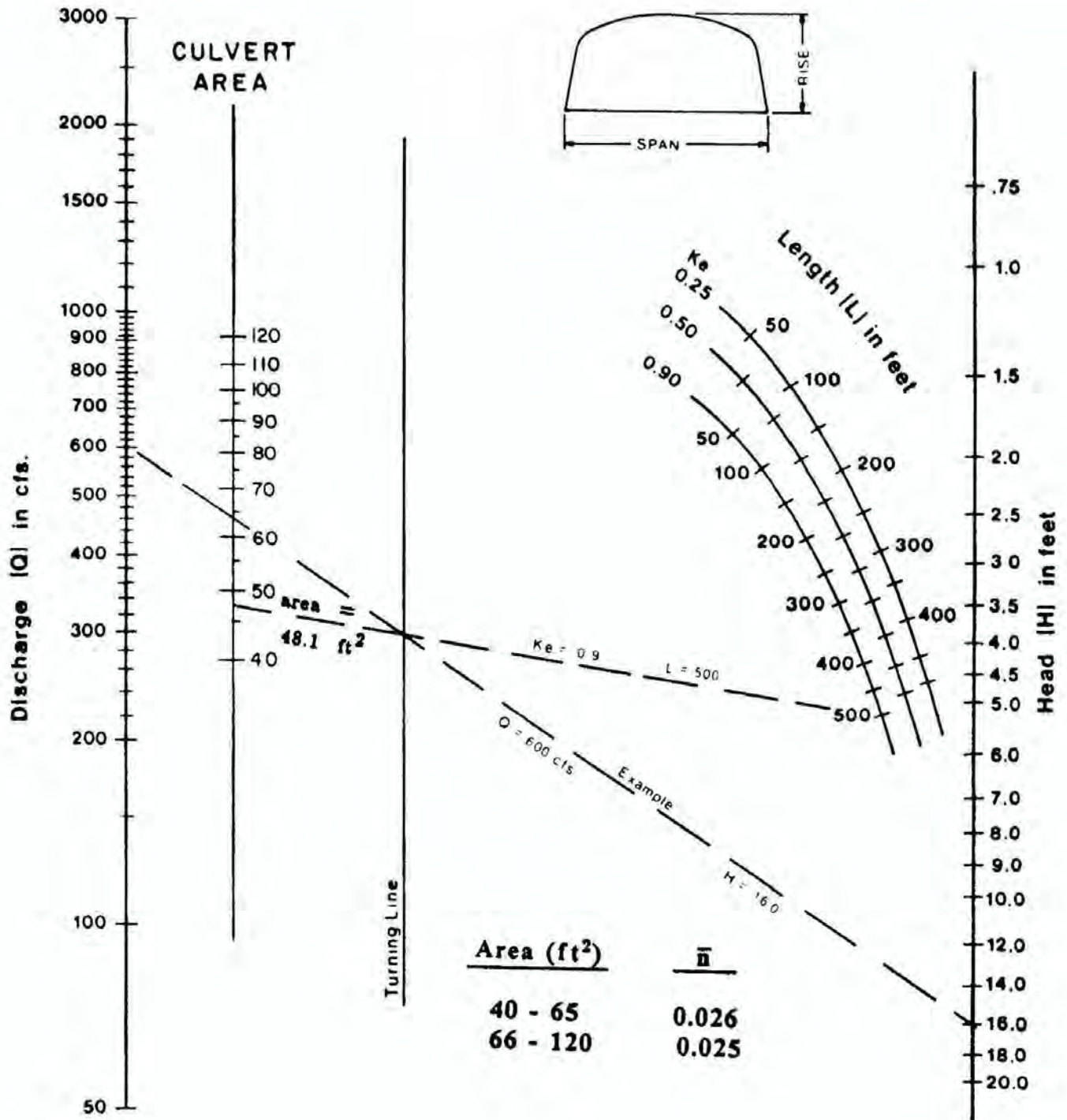
**HEAD FOR  
C. M. BOX CULVERTS  
FLOWING FULL  
CONCRETE BOTTOM  
 $0.4 \leq \text{RISE} / \text{SPAN} < 0.5$**

Nomographs adapted from material furnished by Kaiser Aluminum and Chemical Corporation

Duplication of this nomograph may distort scale



# CHART 24



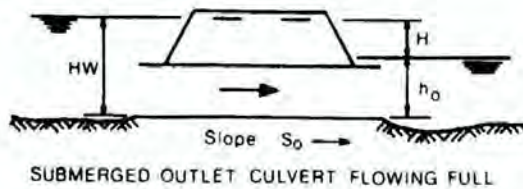
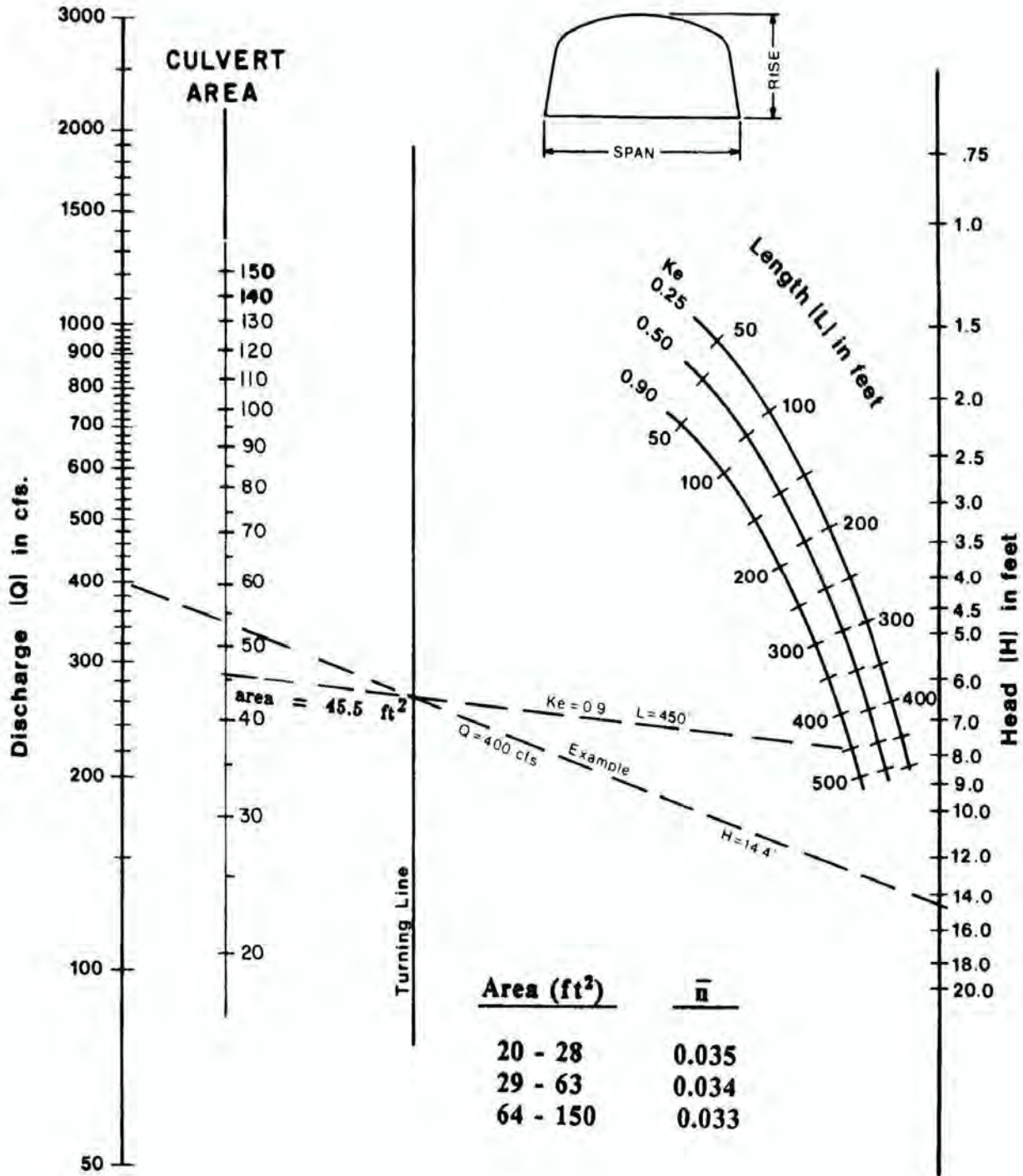
**HEAD FOR  
C. M. BOX CULVERTS  
FLOWING FULL  
CONCRETE BOTTOM**

**0.5 ≤ RISE / SPAN**

Nomographs adapted from material furnished by Kaiser Aluminum and Chemical Corporation

Duplication of this nomograph may distort scale

# CHART 25



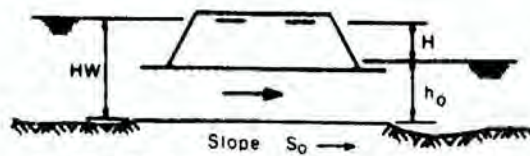
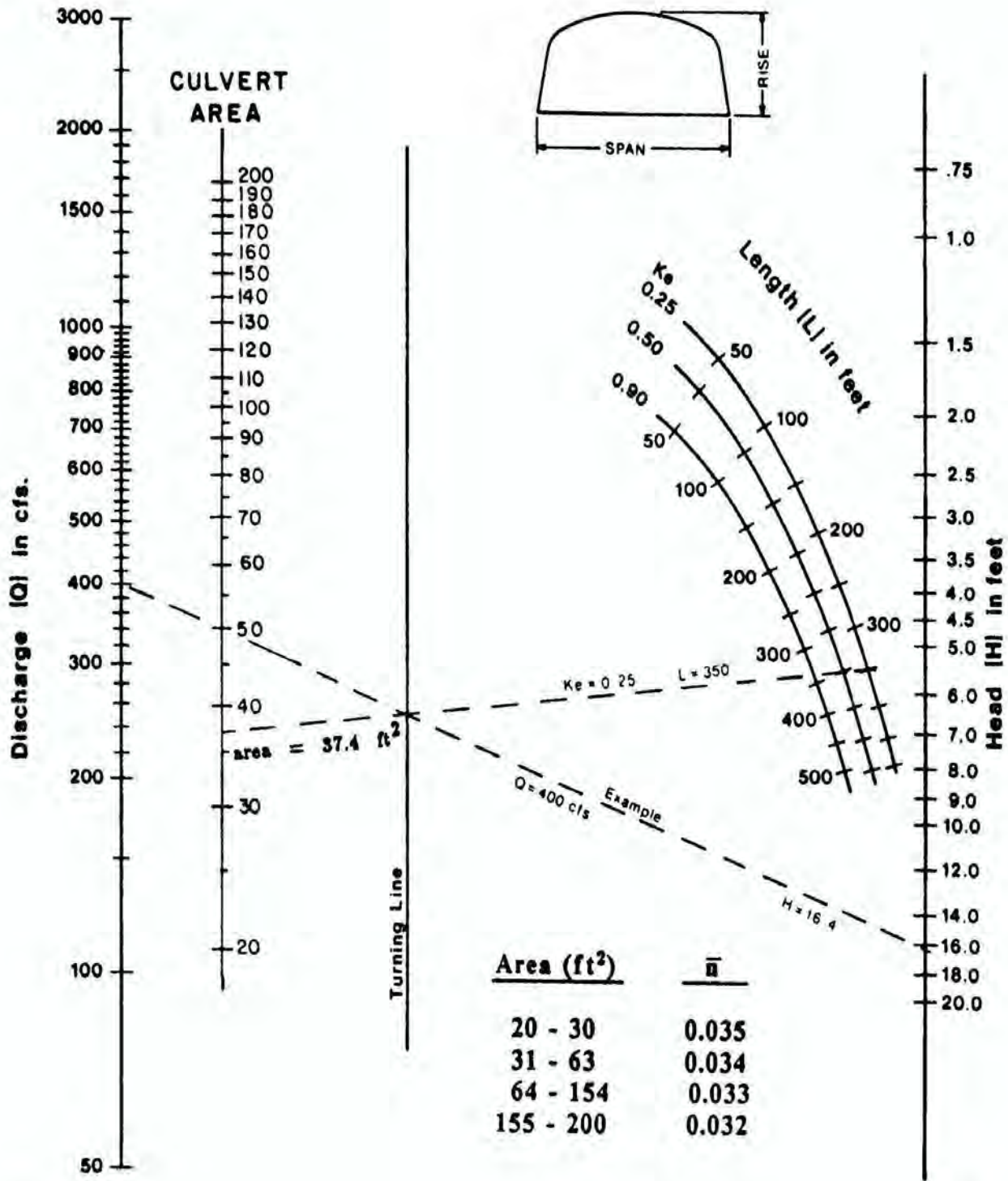
**HEAD FOR  
C. M. BOX CULVERTS  
FLOWING FULL  
CORRUGATED METAL BOTTOM  
RISE / SPAN < 0.3**

Nomographs adapted from material furnished by  
Kaiser Aluminum and Chemical Corporation

Duplication of this nomograph may distort scale



# CHART 26



SUBMERGED OUTLET CULVERT FLOWING FULL

**HEAD FOR  
C. M. BOX CULVERTS  
FLOWING FULL**

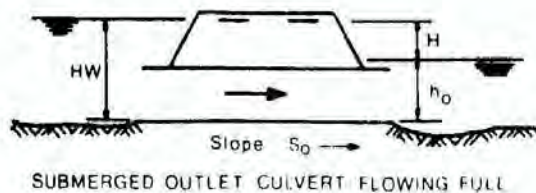
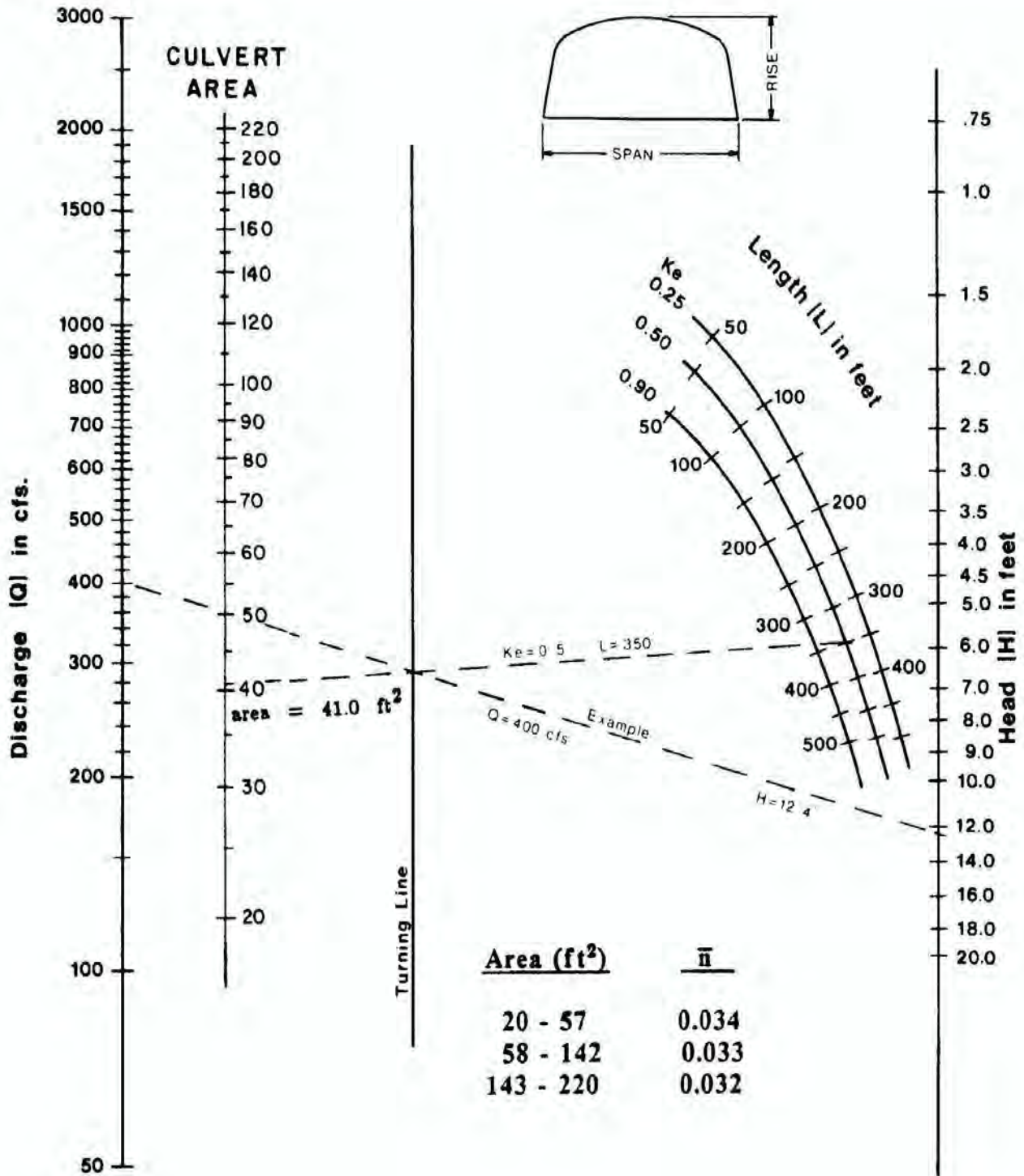
**CORRUGATED METAL BOTTOM**

**0.3 ≤ RISE / SPAN < 0.4**

Nomographs adapted from material furnished by Kaiser Aluminum and Chemical Corporation

Duplication of this nomograph may distort scale

# CHART 27



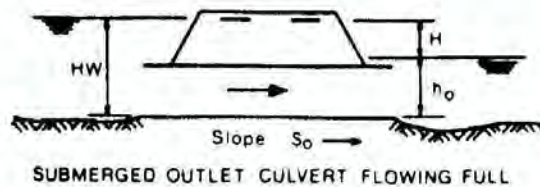
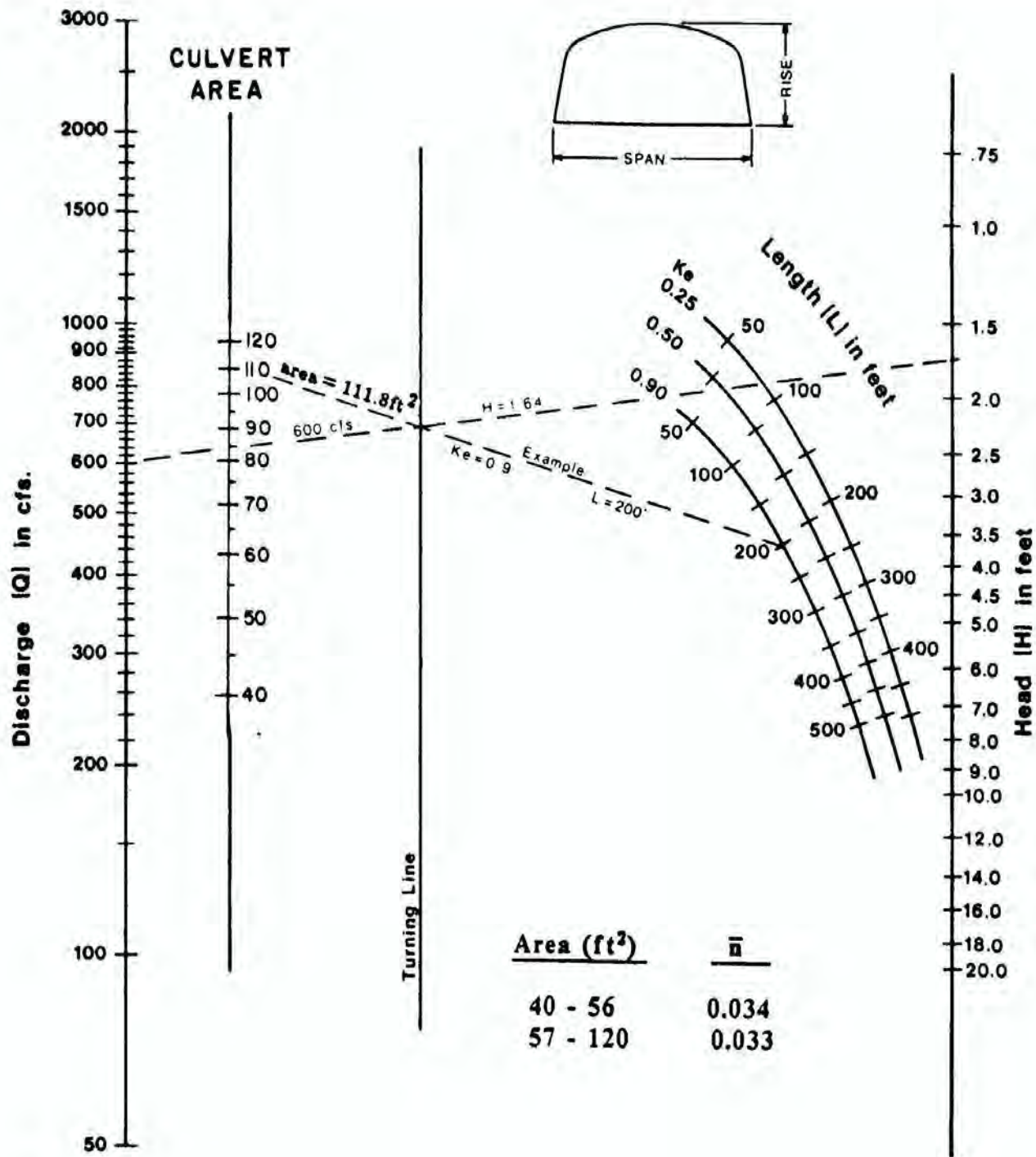
**HEAD FOR  
C. M. BOX CULVERTS  
FLOWING FULL  
CORRUGATED METAL BOTTOM  
 $0.4 \leq \text{RISE} / \text{SPAN} < 0.5$**

Nomographs adapted from material furnished by  
Kaiser Aluminum and Chemical Corporation

Duplication of this nomograph may distort scale



# CHART 28



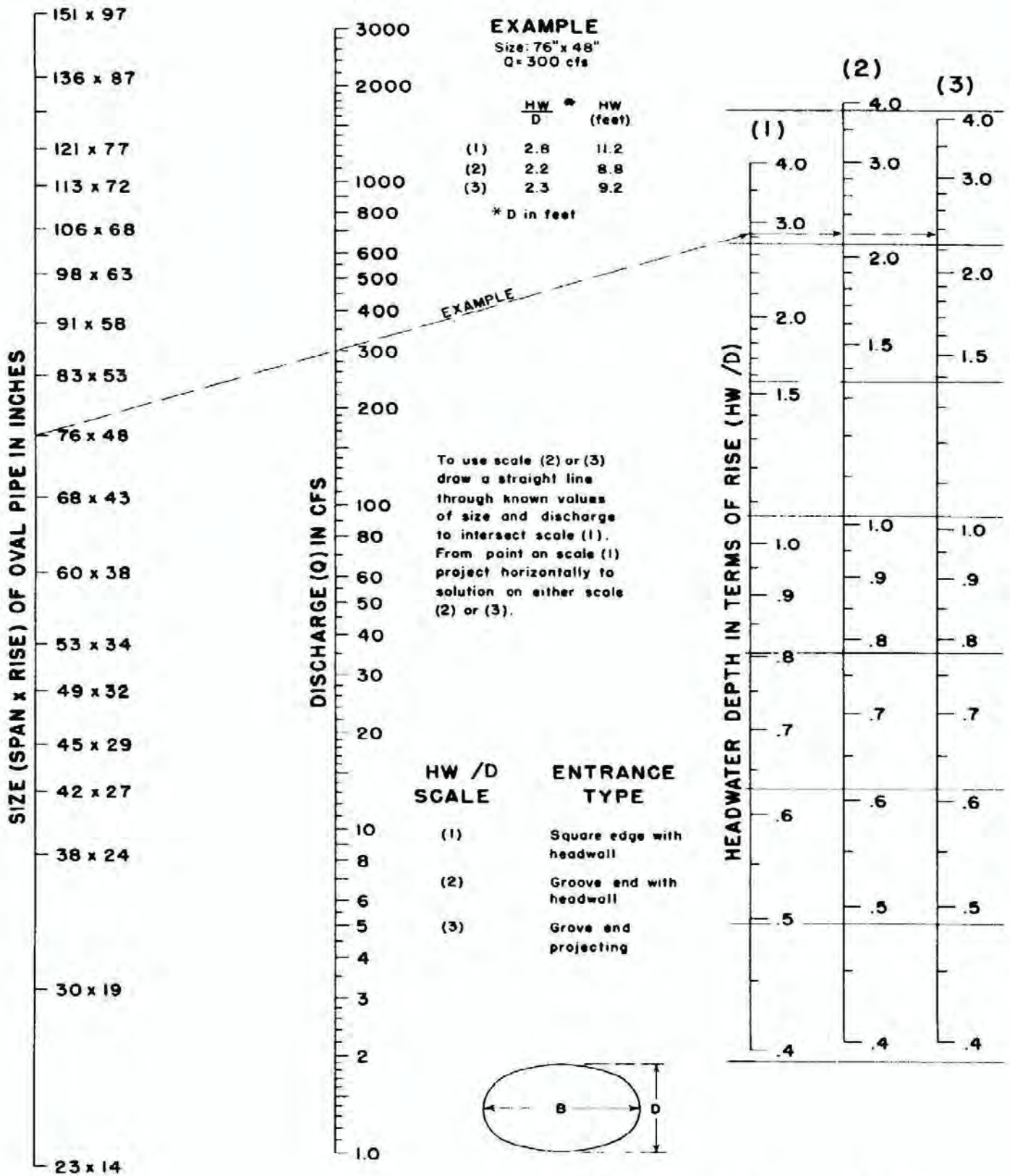
**HEAD FOR  
C. M. BOX CULVERTS  
FLOWING FULL  
CORRUGATED METAL BOTTOM  
0.5 ≤ RISE / SPAN**

Nomographs adapted from material furnished by  
Kaiser Aluminum and Chemical Corporation

Duplication of this nomograph may distort scale

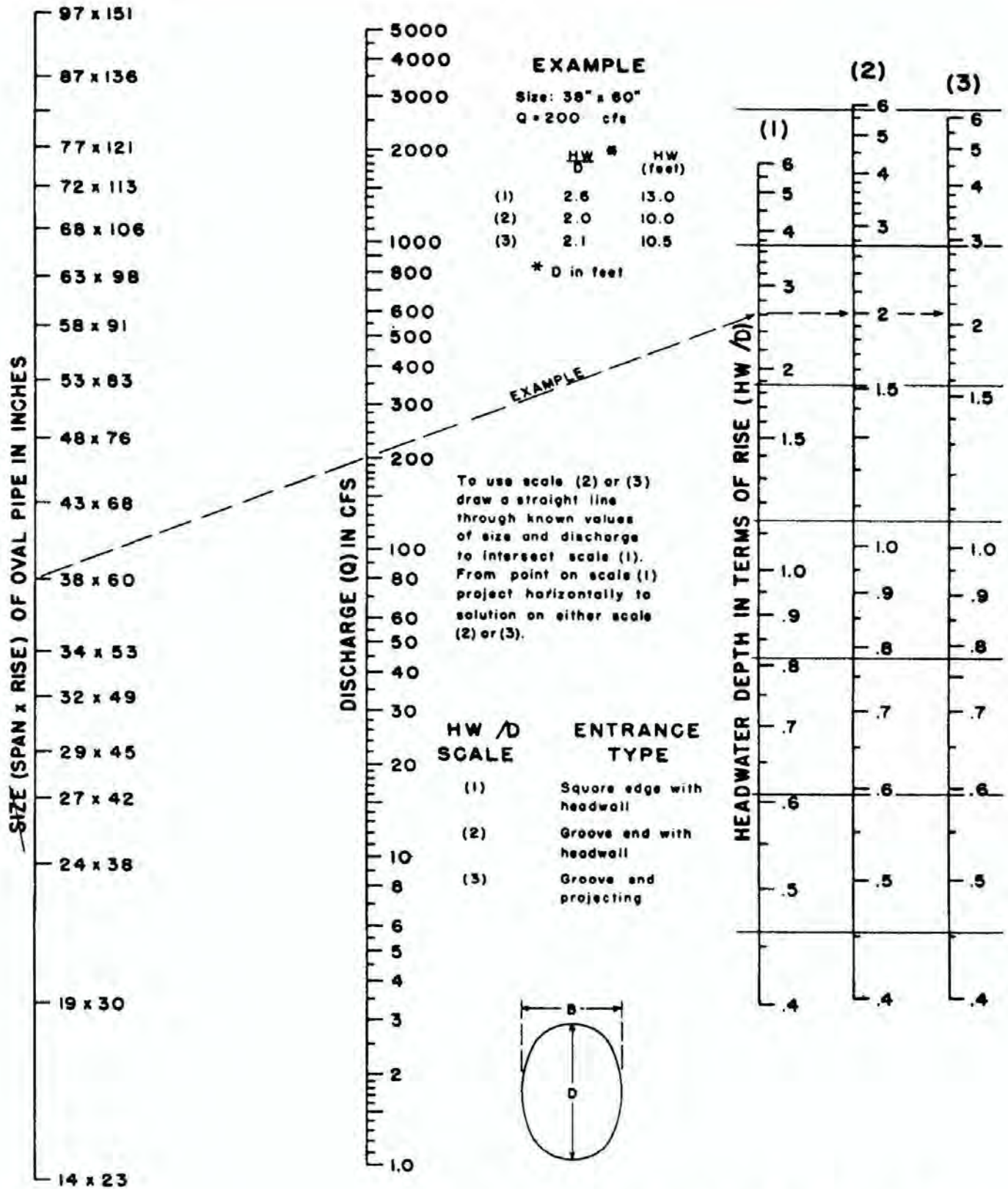


# CHART 29



## HEADWATER DEPTH FOR OVAL CONCRETE PIPE CULVERTS LONG AXIS HORIZONTAL WITH INLET CONTROL

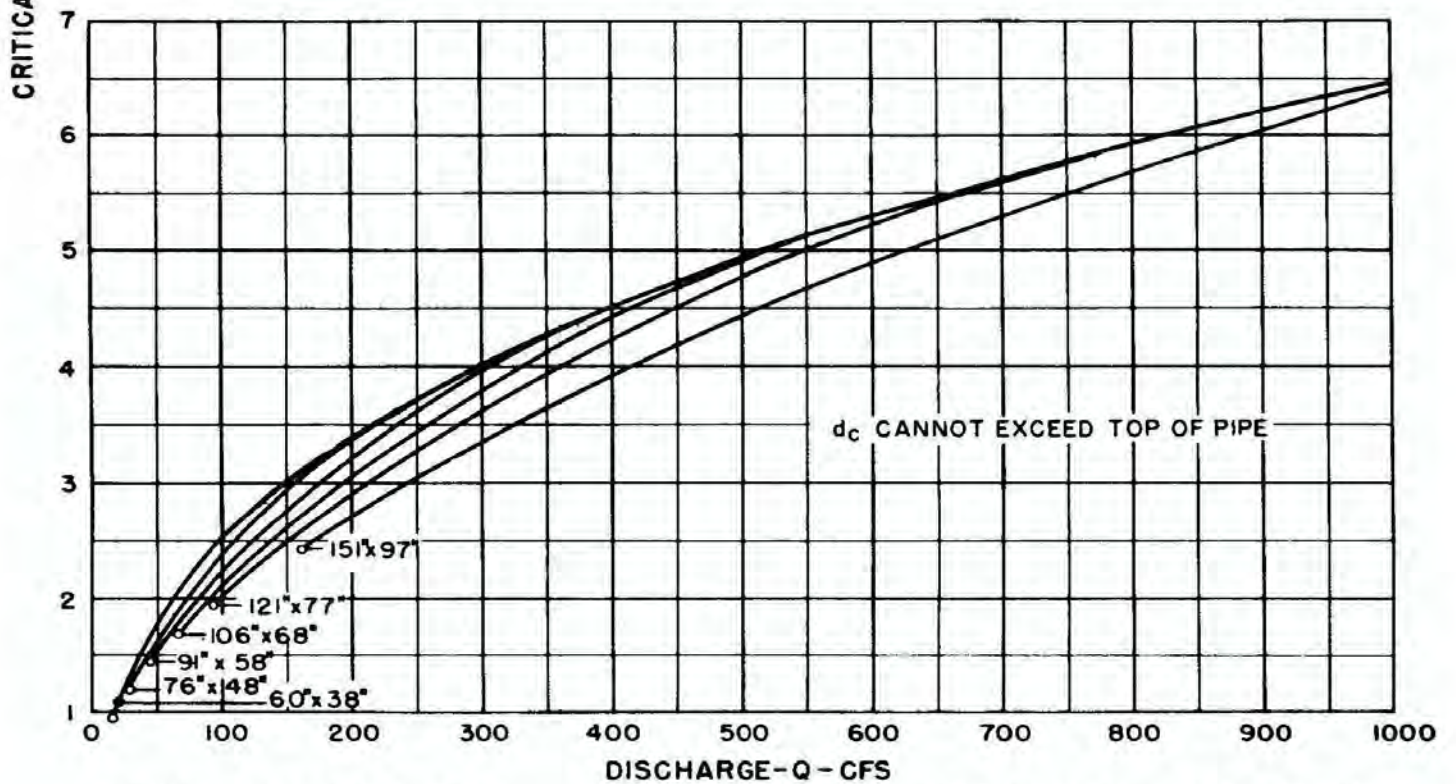
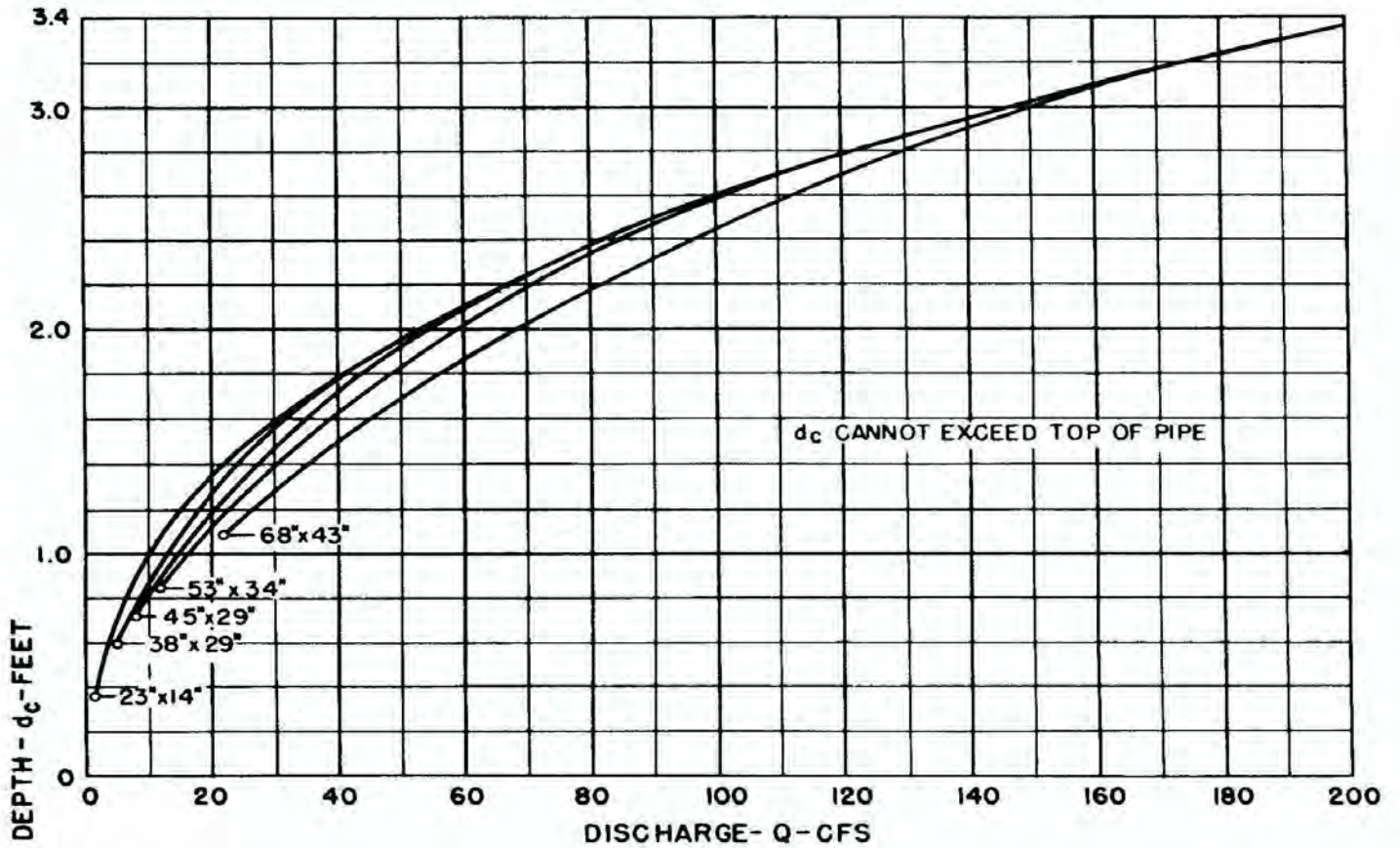
# CHART 30



## HEADWATER DEPTH FOR OVAL CONCRETE PIPE CULVERTS LONG AXIS VERTICAL WITH INLET CONTROL



# CHART 31



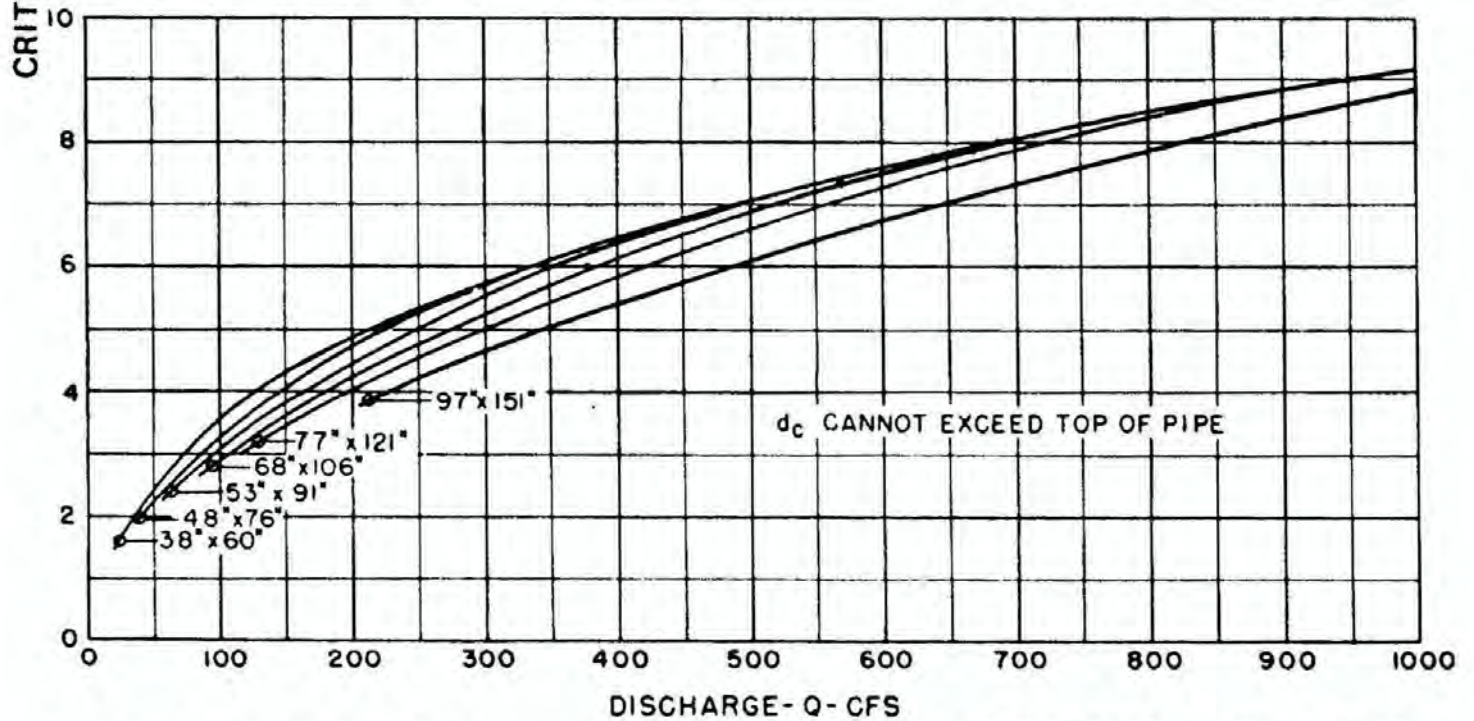
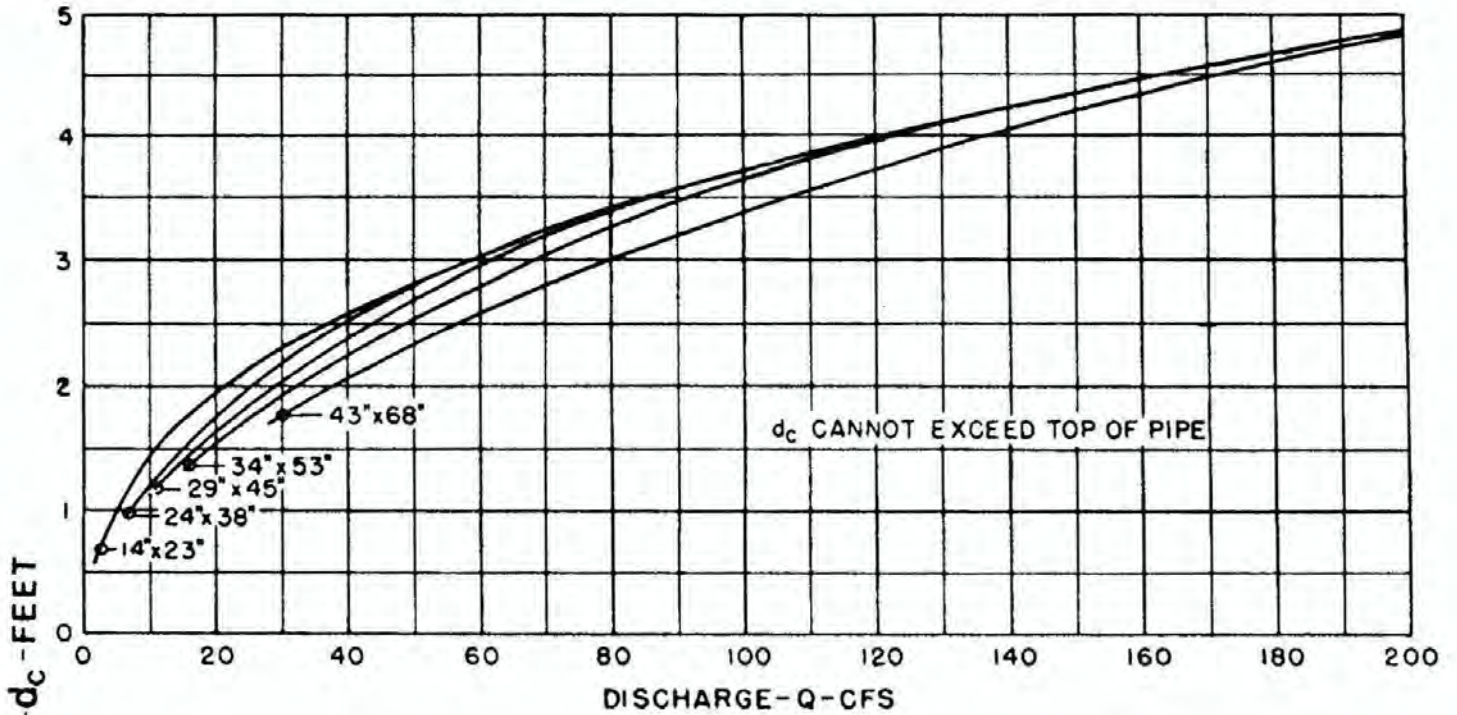
BUREAU OF PUBLIC ROADS

JAN. 1964

**CRITICAL DEPTH  
OVAL CONCRETE PIPE  
LONG AXIS HORIZONTAL**



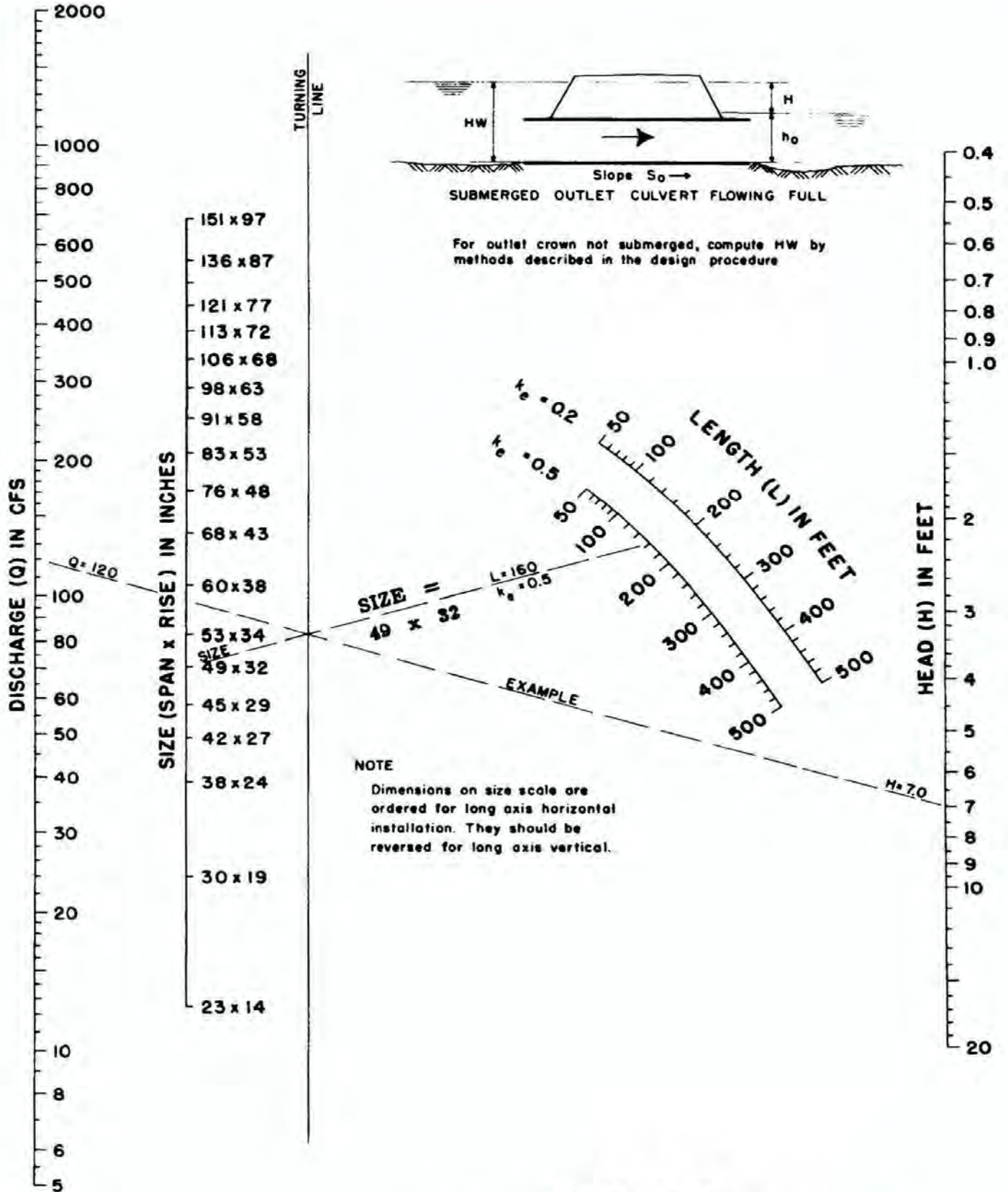
# CHART 32



BUREAU OF PUBLIC ROADS  
 JAN. 1964

CRITICAL DEPTH  
 OVAL CONCRETE PIPE  
 LONG AXIS VERTICAL

# CHART 33

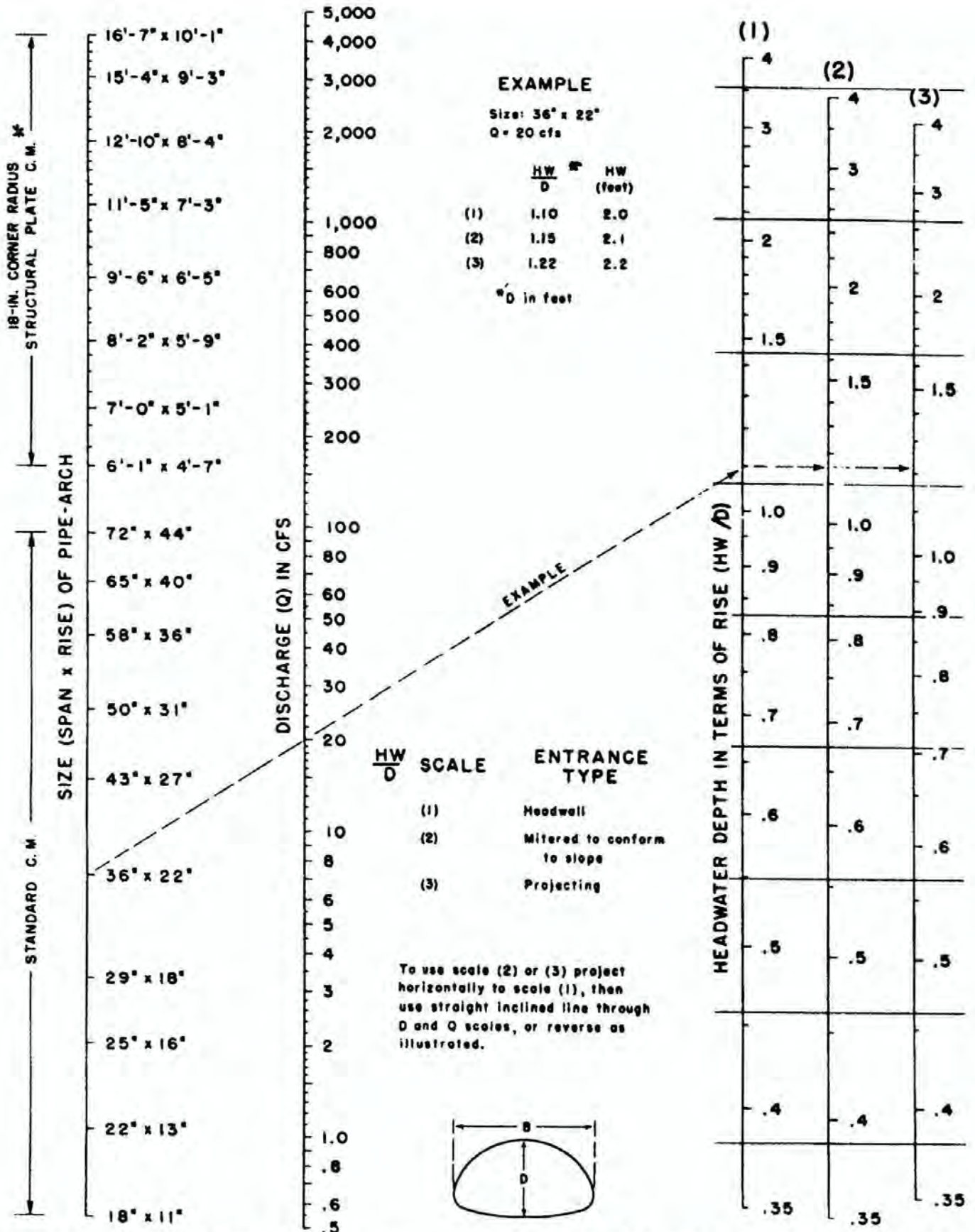


## HEAD FOR OVAL CONCRETE PIPE CULVERTS LONG AXIS HORIZONTAL OR VERTICAL FLOWING FULL

$n = 0.012$



# CHART 34



\* ADDITIONAL SIZES NOT DIMENSIONED ARE LISTED IN FABRICATOR'S CATALOG

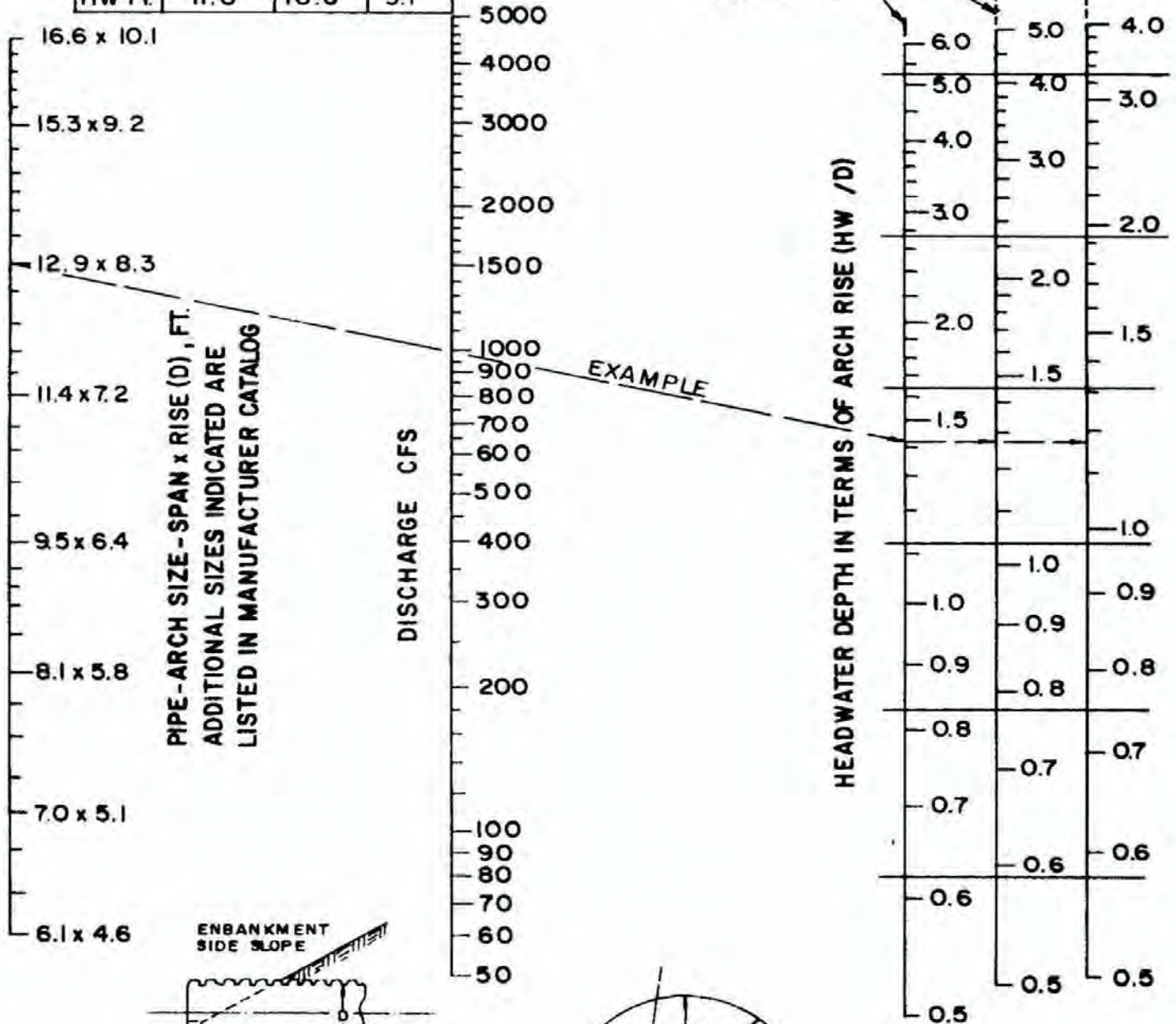
BUREAU OF PUBLIC ROADS JAN. 1963

# CHART 35

**EXAMPLE**  
 SIZE 12.9' x 8.3' Q=1000 CFS

|        | PROJECT | HEADWALL |       |
|--------|---------|----------|-------|
|        |         | NO BEV.  | BEVEL |
| HW / D | 1.42    | 1.27     | 1.17  |
| HW Ft. | 11.8    | 10.5     | 9.7   |

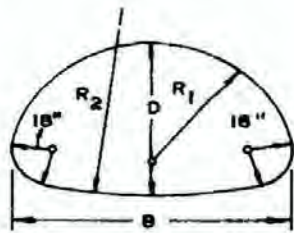
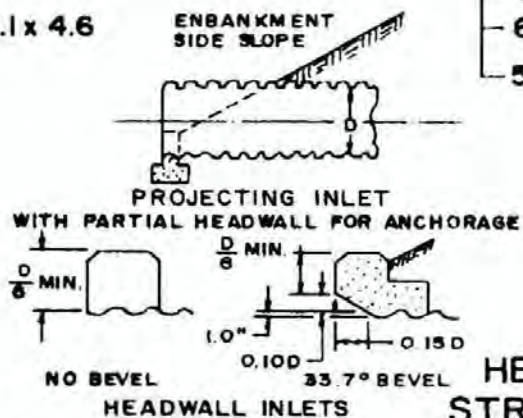
TYPE OF INLET  
 90° HEADWALL :  
 33.7° x 0.100 BEVEL  
 NO BEVEL  
 PROJECTING



PIPE-ARCH SIZE - SPAN x RISE (D), FT.  
 ADDITIONAL SIZES INDICATED ARE  
 LISTED IN MANUFACTURER CATALOG

EXAMPLE

HEADWATER DEPTH IN TERMS OF ARCH RISE (HW / D)



**HEADWATER DEPTH FOR INLET CONTROL  
 STRUCTURAL PLATE PIPE-ARCH CULVERTS**  
 18-IN. RADIUS CORNER PLATE  
 PROJECTING OR HEADWALL INLET  
 HEADWALL WITH OR WITHOUT EDGE BEVEL

BUREAU OF PUBLIC ROADS  
 OFFICE OF R & D JULY 1968



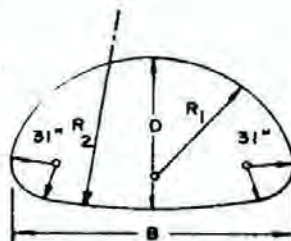
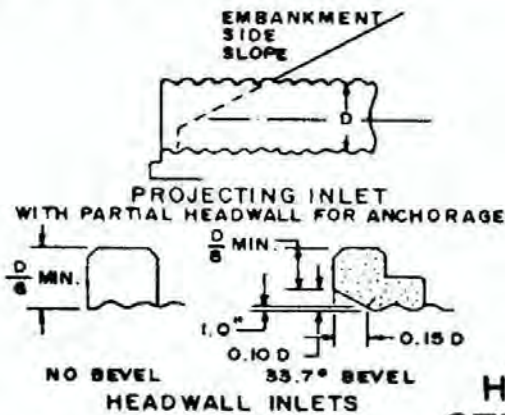
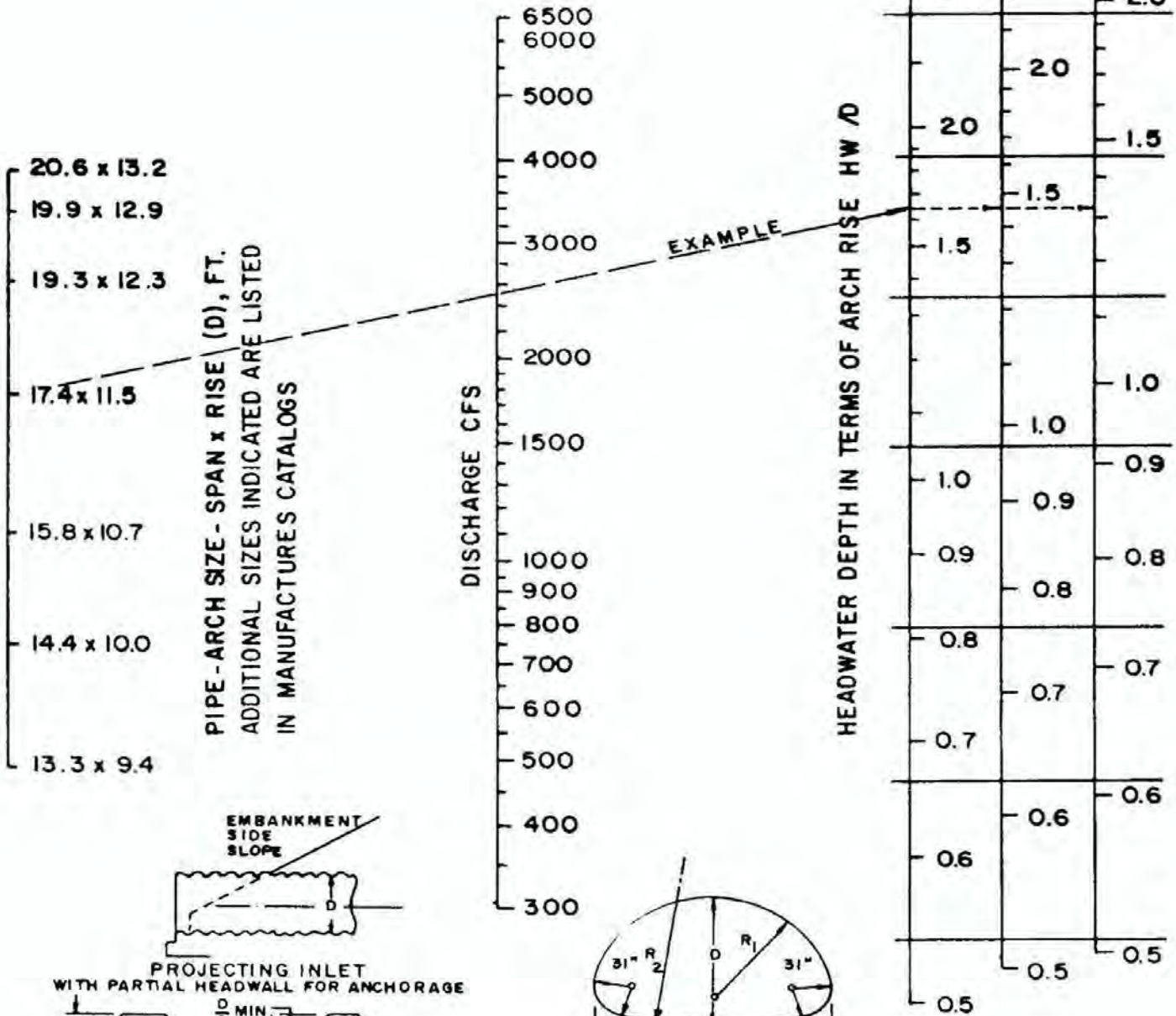
# CHART 36

**EXAMPLE**  
 SIZE 17.4' x 11.5' Q = 2500 CFS

|        | PROJECT | HEADWALL |       |
|--------|---------|----------|-------|
|        |         | NO BEV.  | BEVEL |
| HW /D  | 164     | 1.45     | 1.32  |
| HW FT. | 18.9    | 16.7     | 15.2  |

TYPE OF INLET

90° HEADWALL  
 33.7° x 0.10D BEVEL  
 NO BEVEL  
 PROJECTING



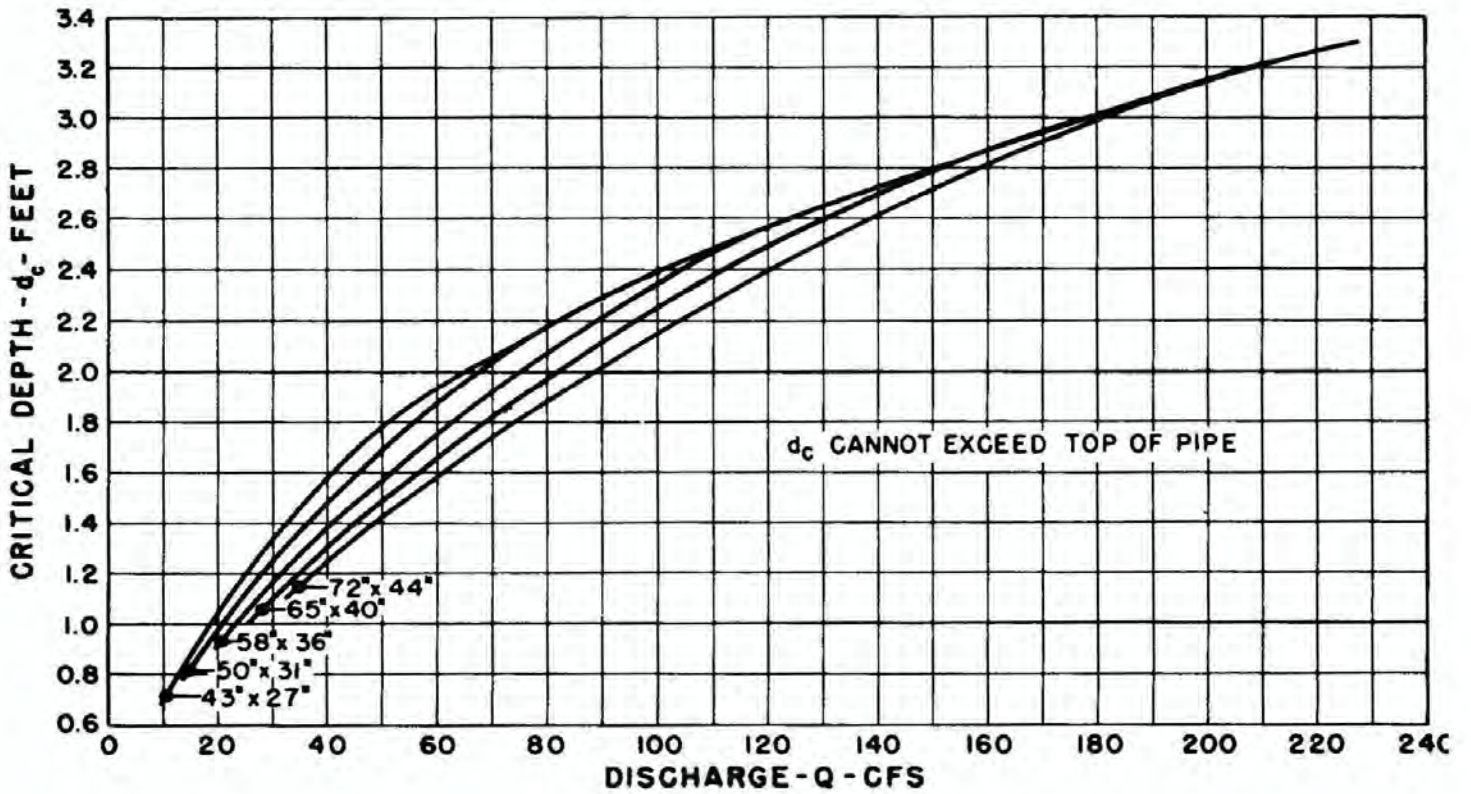
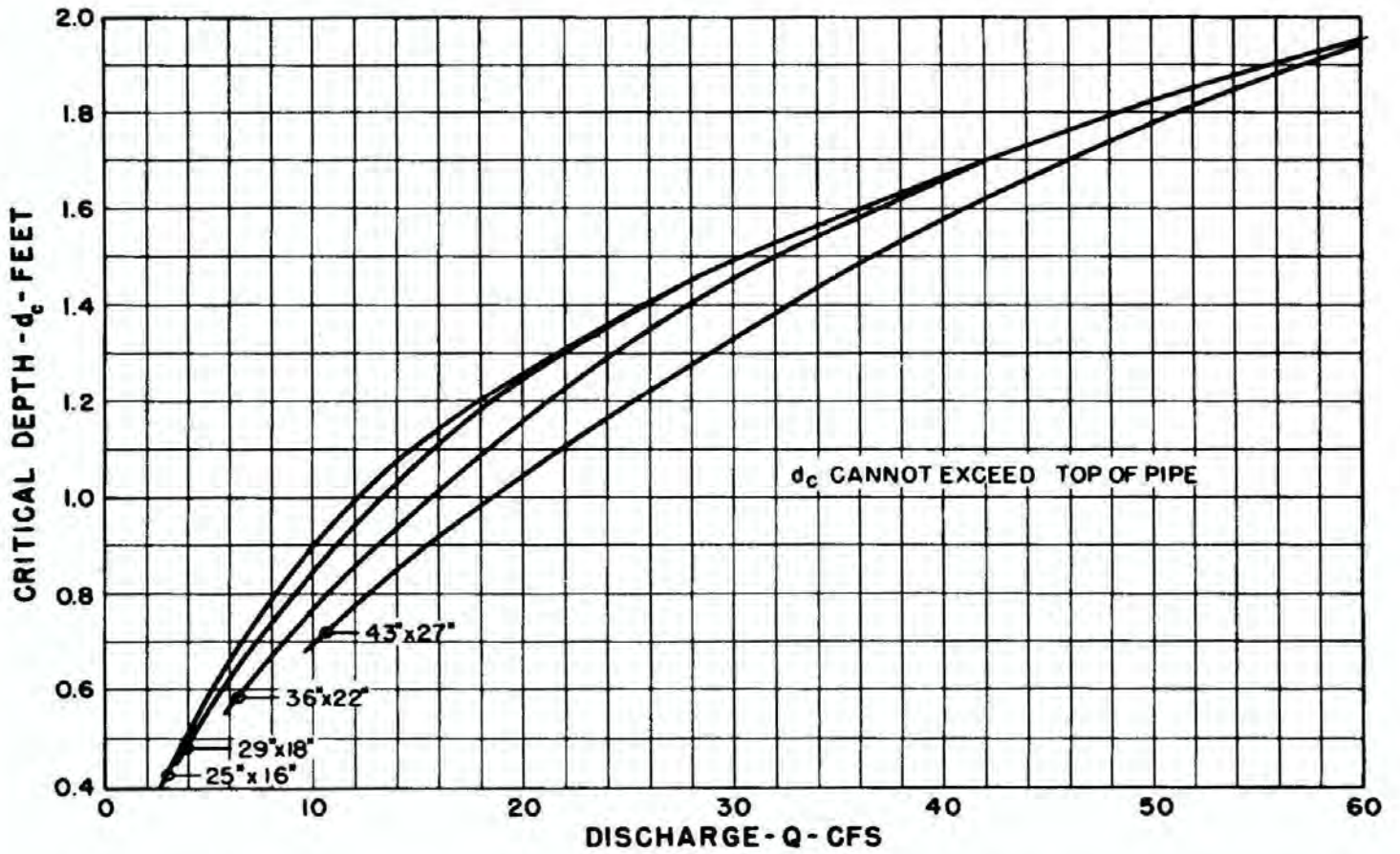
## HEADWATER DEPTH FOR INLET CONTROL STRUCTURAL PLATE PIPE-ARCH CULVERTS

31-IN. RADIUS CORNER PLATE  
 PROJECTING OR HEADWALL INLET  
 HEADWALL WITH OR WITHOUT EDGE BEVEL

BUREAU OF PUBLIC ROADS  
 OFFICE OF RSD JULY 1966



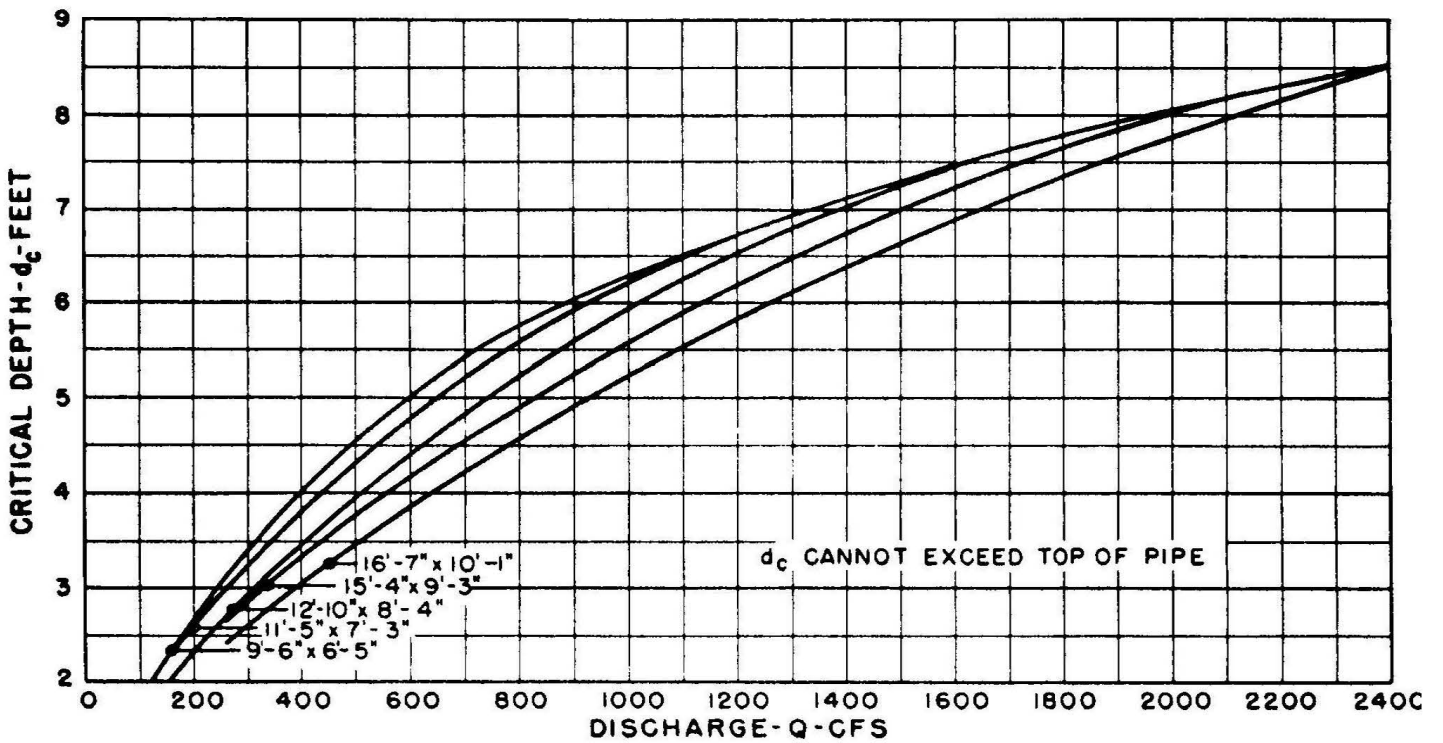
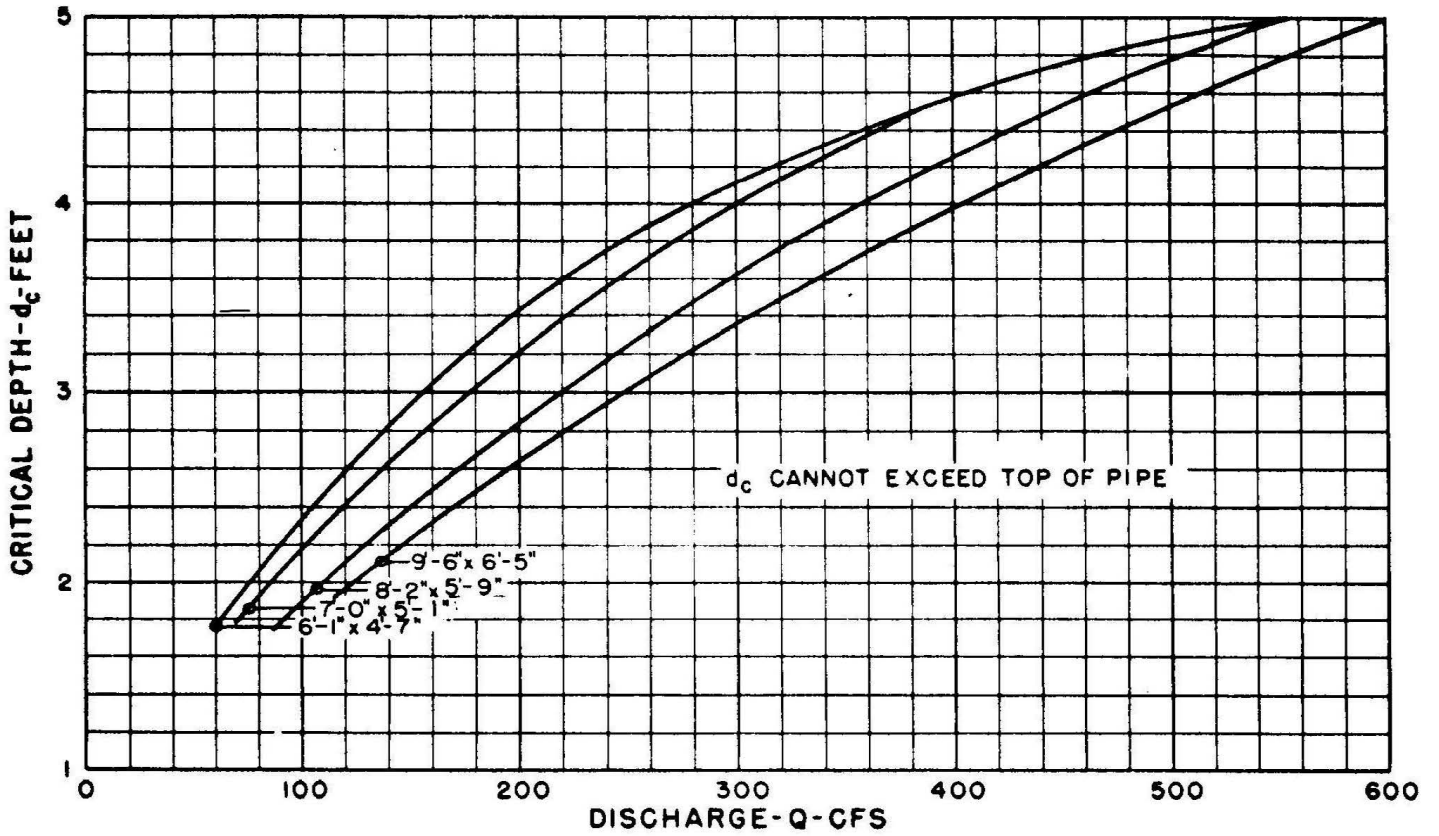
CHART 37



BUREAU OF PUBLIC ROADS  
JAN. 1964

CRITICAL DEPTH  
STANDARD C.M. PIPE-ARCH

# CHART 38



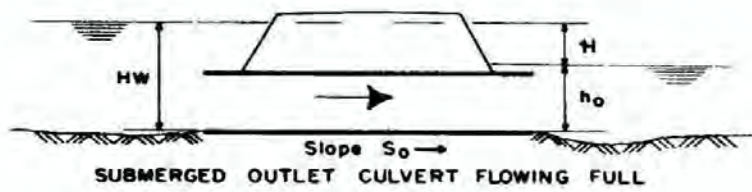
BUREAU OF PUBLIC ROADS

JAN. 1964

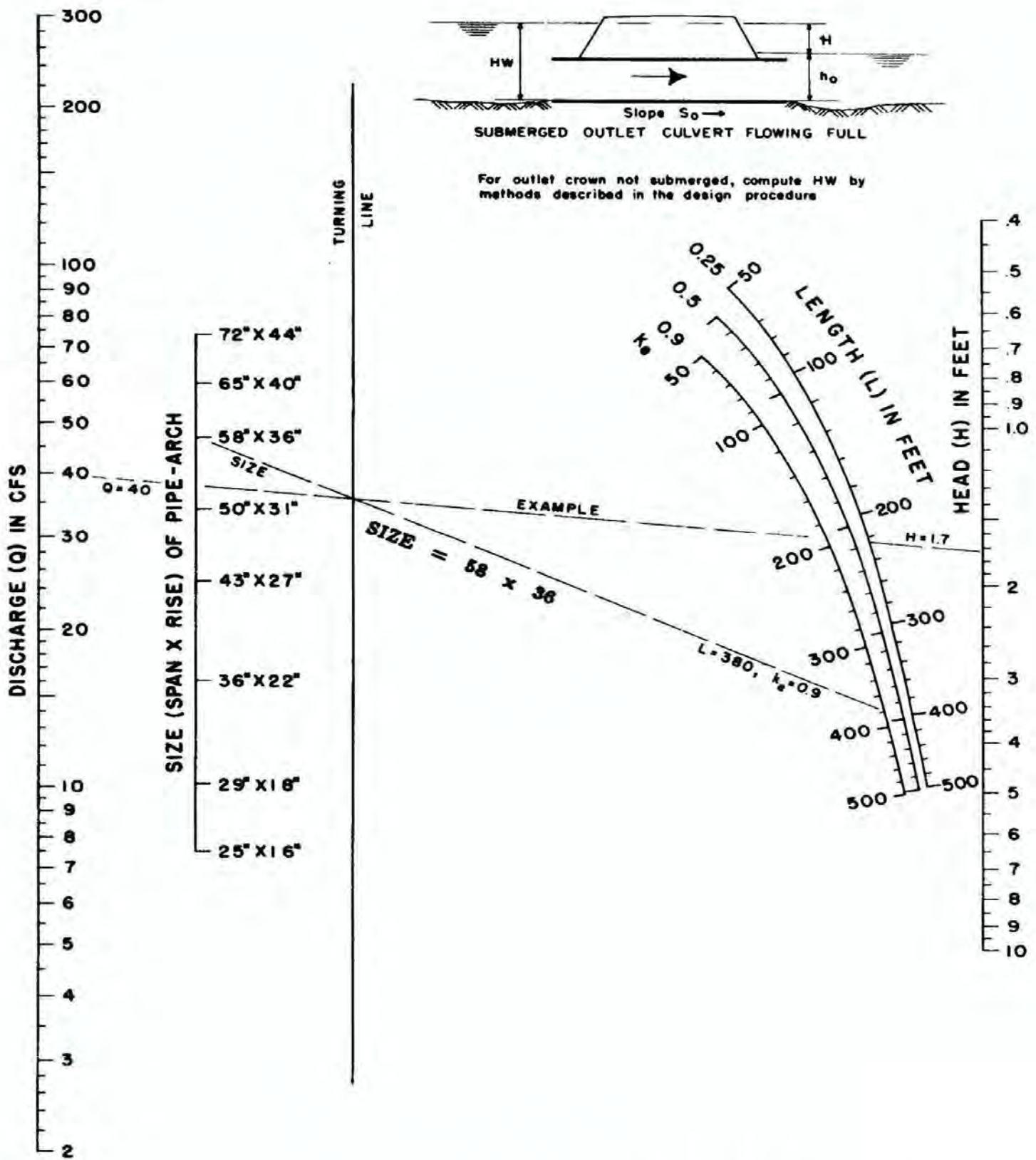
CRITICAL DEPTH  
STRUCTURAL PLATE  
C. M. PIPE - ARCH  
18 INCH CORNER RADIUS



# CHART 39



For outlet crown not submerged, compute HW by methods described in the design procedure



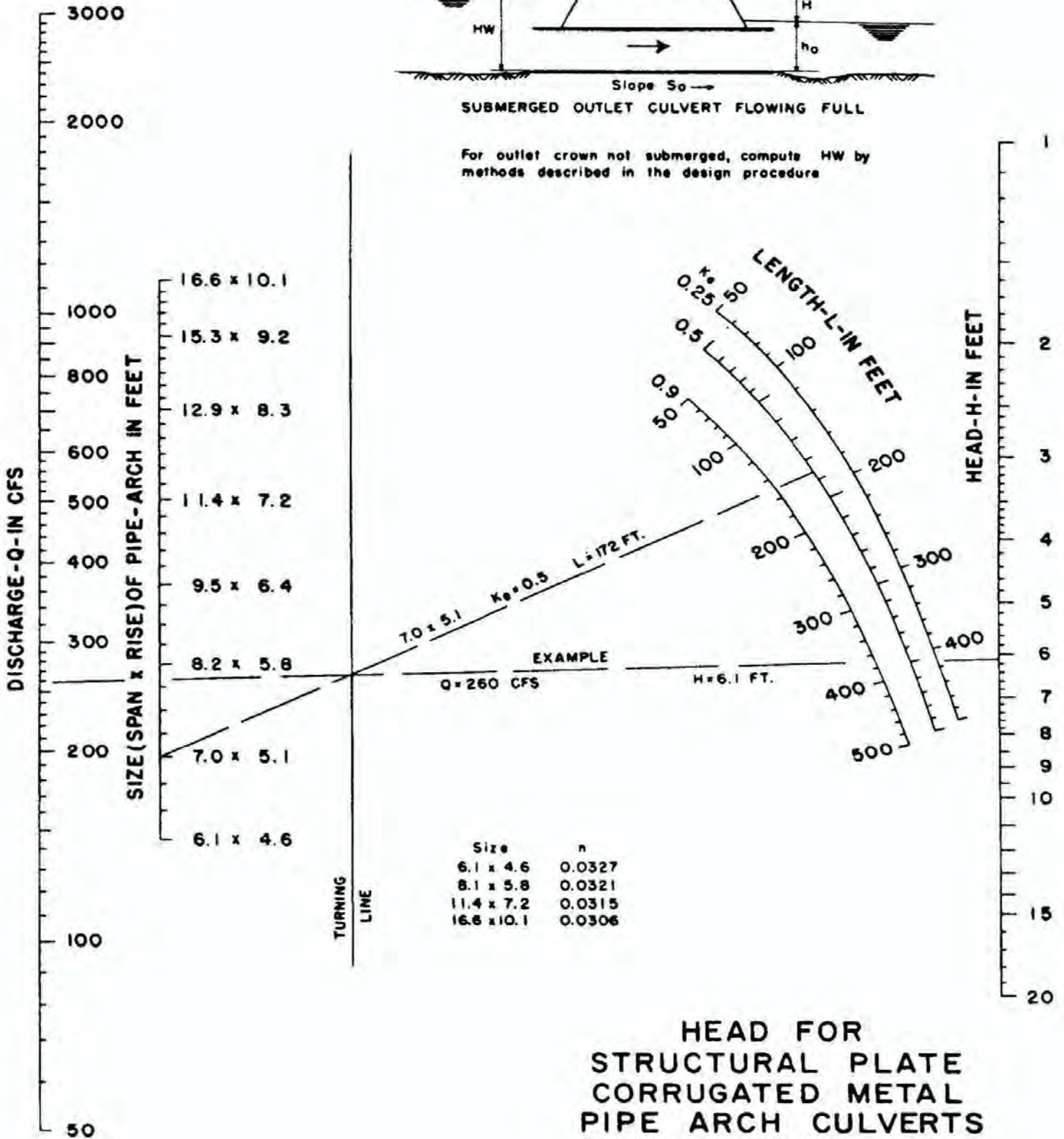
**HEAD FOR  
STANDARD C. M. PIPE-ARCH CULVERTS  
FLOWING FULL  
 $n = 0.024$**

# CHART 40



SUBMERGED OUTLET CULVERT FLOWING FULL

For outlet crown not submerged, compute HW by methods described in the design procedure

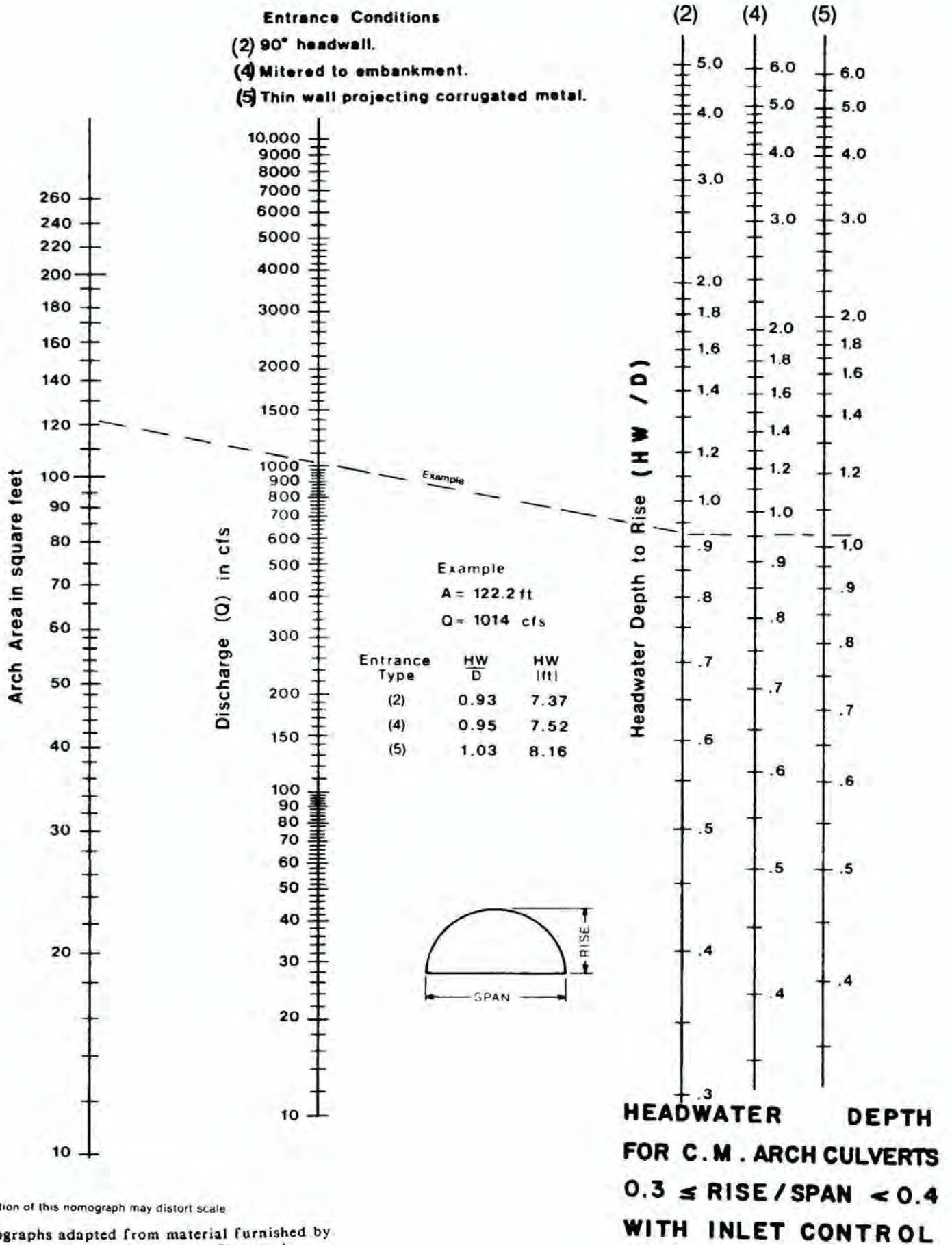


| Size        | n      |
|-------------|--------|
| 6.1 x 4.6   | 0.0327 |
| 8.1 x 5.8   | 0.0321 |
| 11.4 x 7.2  | 0.0315 |
| 16.6 x 10.1 | 0.0306 |

**HEAD FOR  
STRUCTURAL PLATE  
CORRUGATED METAL  
PIPE ARCH CULVERTS  
18 IN. CORNER RADIUS  
FLOWING FULL  
n = 0.0327 TO 0.0306**



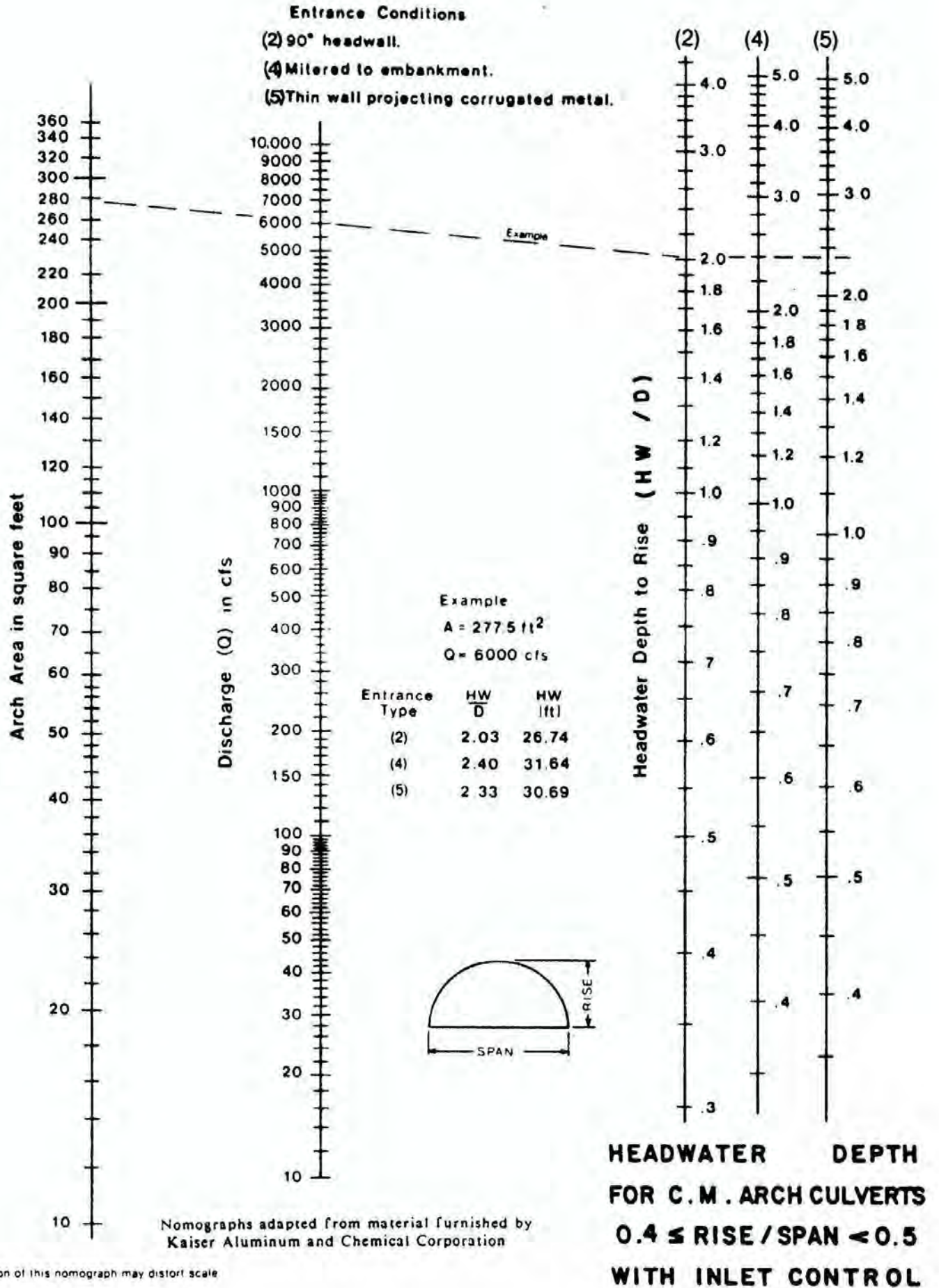
# CHART 41



Duplication of this nomograph may distort scale

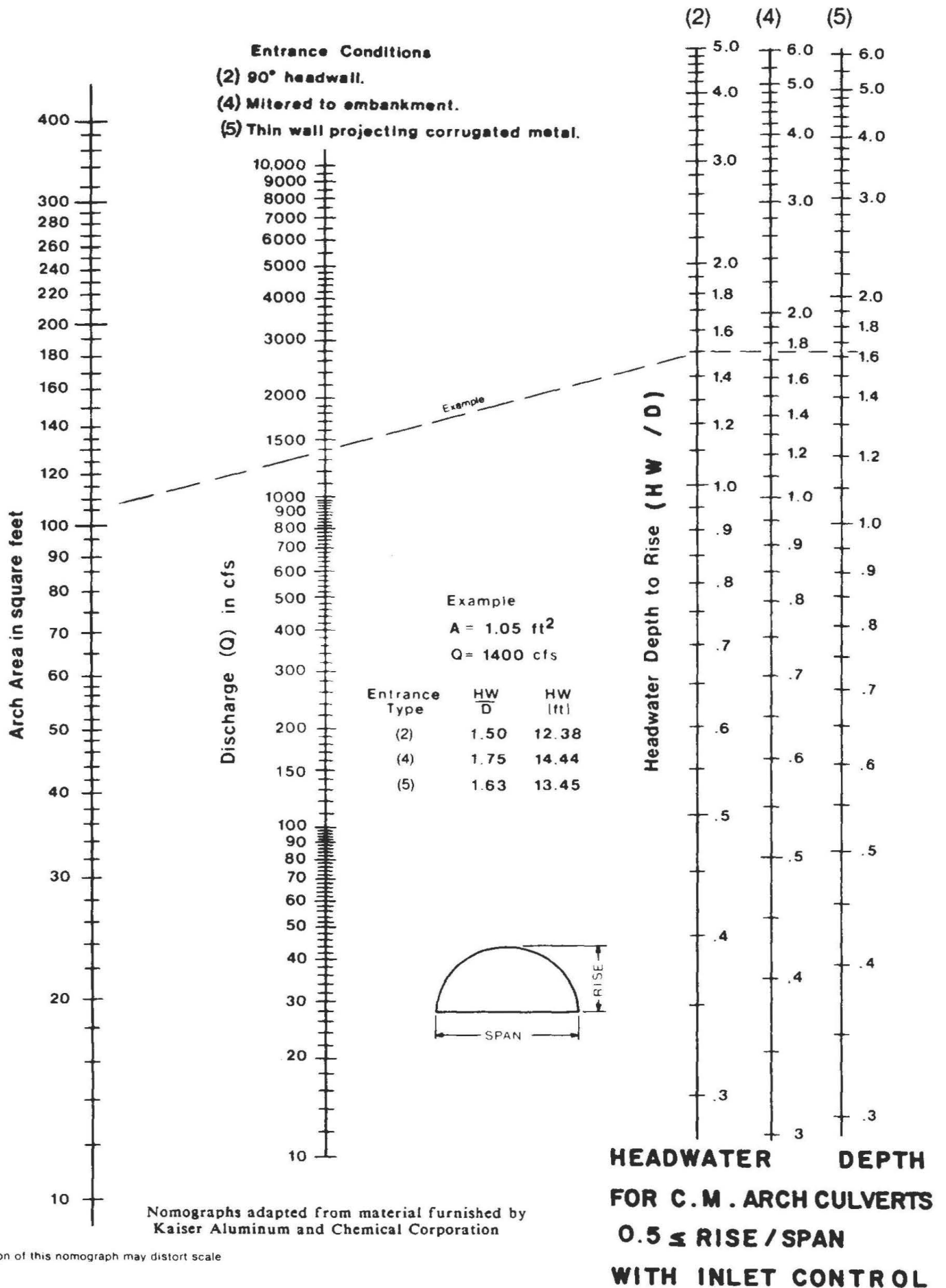
Nomographs adapted from material furnished by Kaiser Aluminum and Chemical Corporation

# CHART 42



Duplication of this nomograph may distort scale

# CHART 43

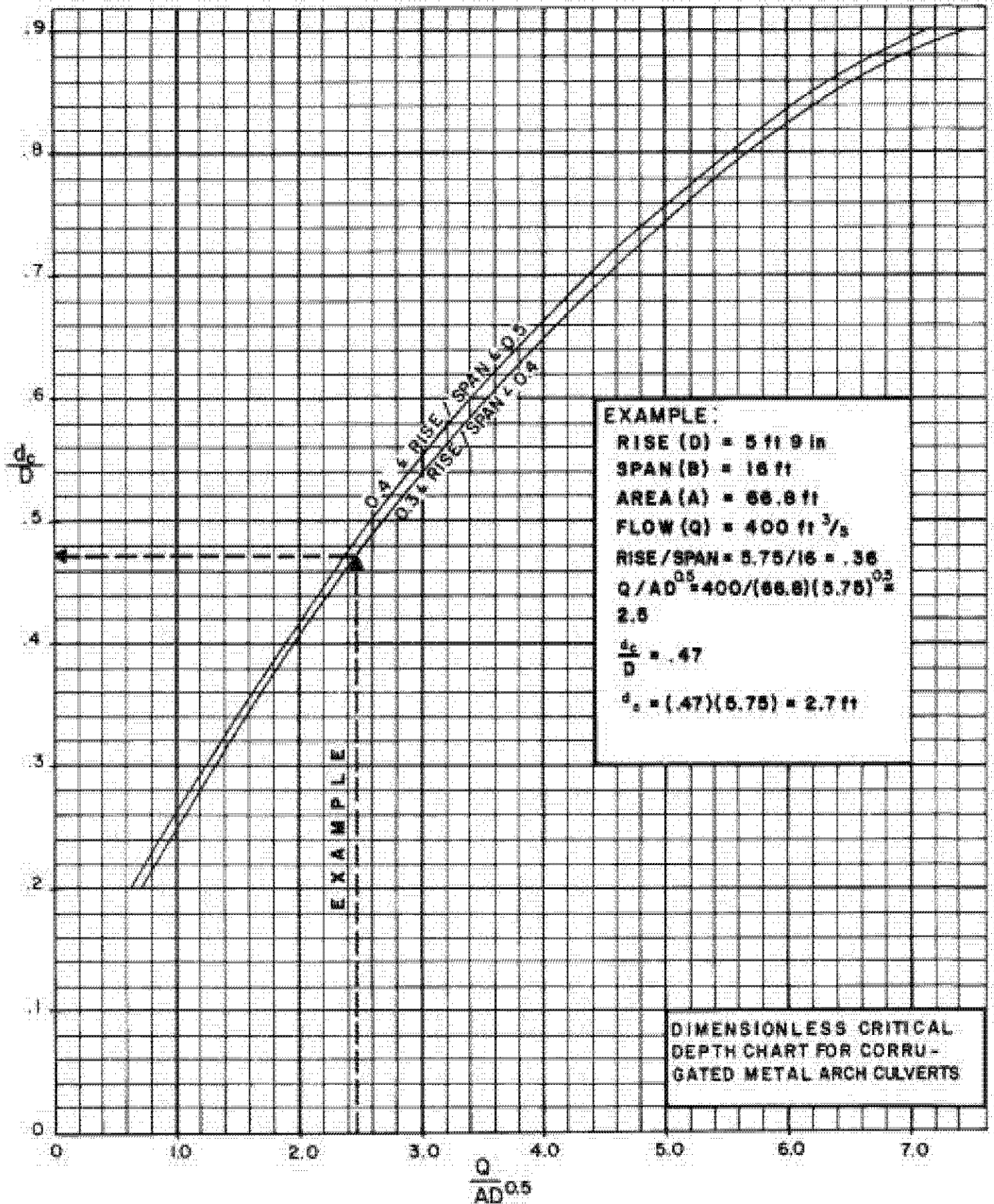


Nomographs adapted from material furnished by Kaiser Aluminum and Chemical Corporation

Duplication of this nomograph may distort scale

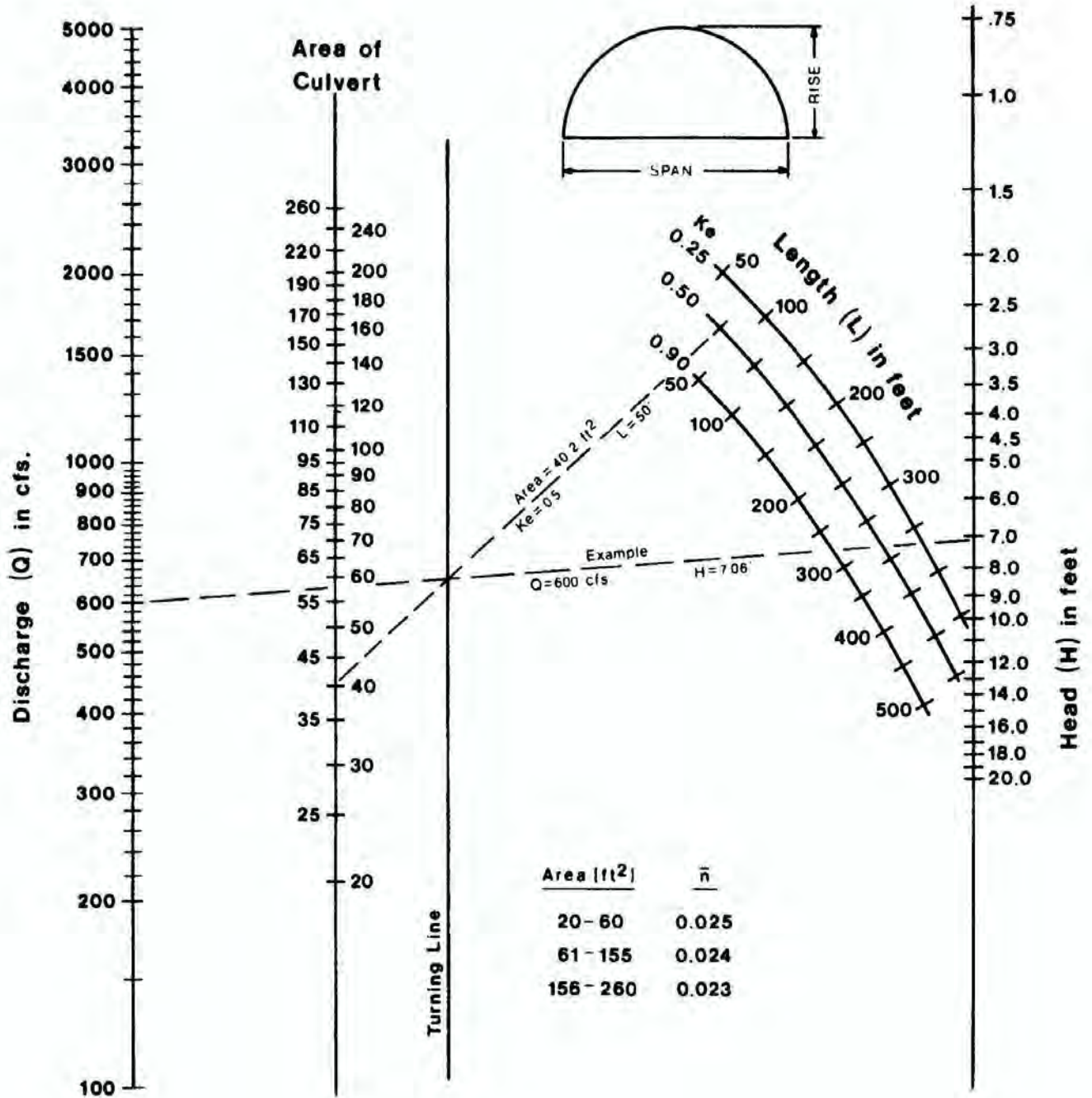


# CHART 44

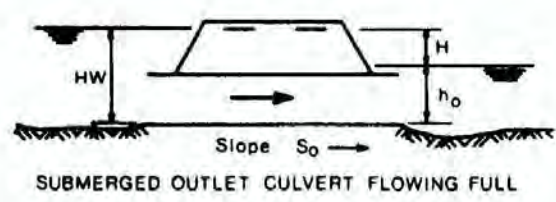




# CHART 45



| Area [ft <sup>2</sup> ] | $\bar{n}$ |
|-------------------------|-----------|
| 20 - 60                 | 0.025     |
| 61 - 155                | 0.024     |
| 156 - 260               | 0.023     |

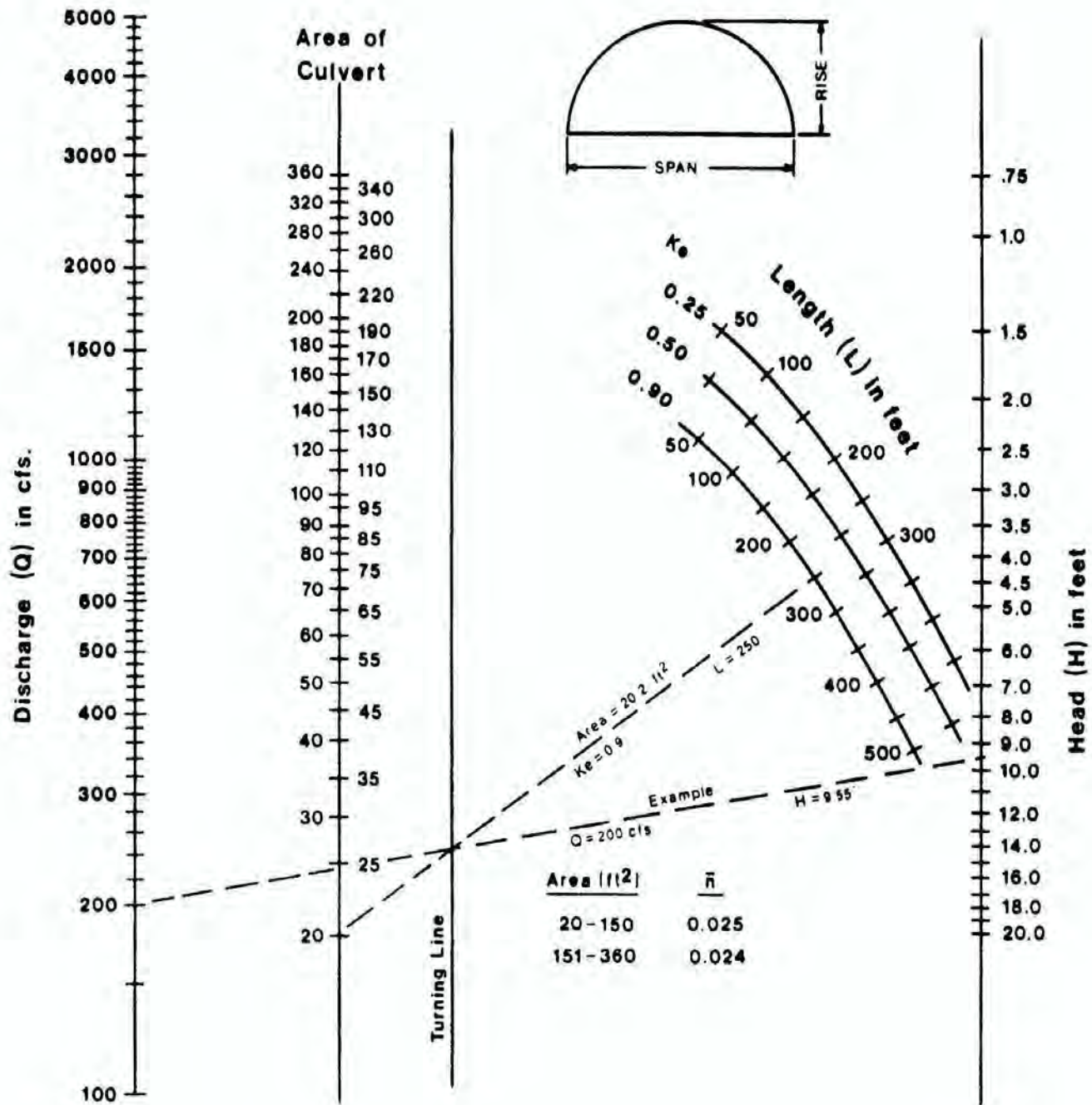


**HEAD FOR  
C.M. ARCH CULVERTS  
FLOWING FULL  
CONCRETE BOTTOM  
 $0.3 \leq \text{RISE} / \text{SPAN} < 0.4$**

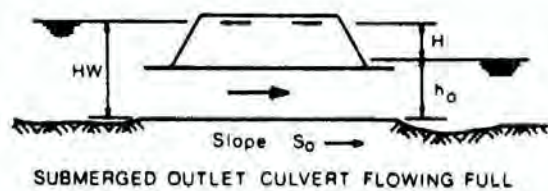
Nomographs adapted from material furnished by Kaiser Aluminum and Chemical Corporation

Duplication of this nomograph may distort scale

# CHART 46



| Area (ft <sup>2</sup> ) | $\bar{n}$ |
|-------------------------|-----------|
| 20 - 150                | 0.025     |
| 151 - 360               | 0.024     |



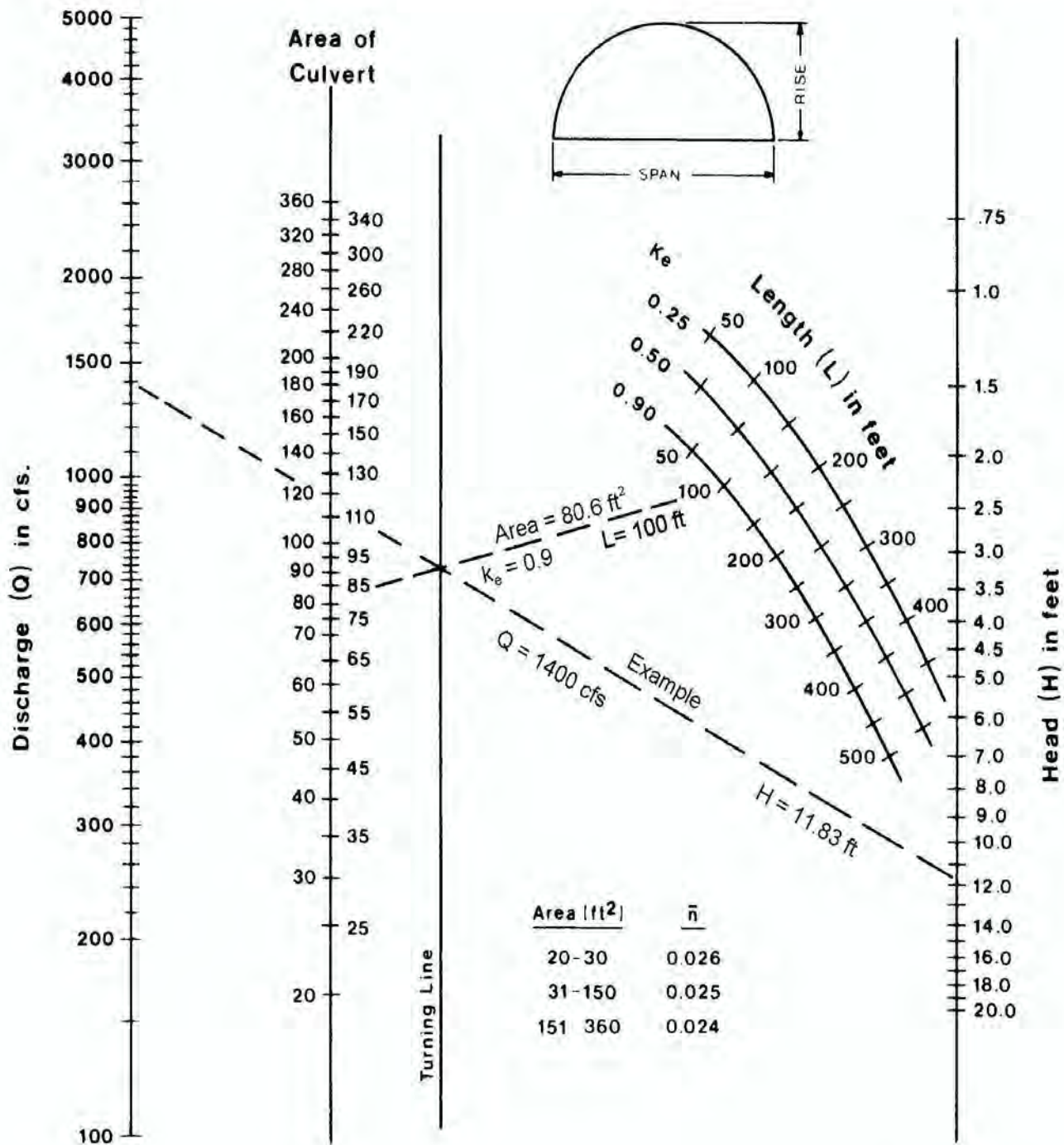
**HEAD FOR  
C.M. ARCH CULVERTS  
FLOWING FULL  
CONCRETE BOTTOM  
 $0.4 \leq \text{RISE} / \text{SPAN} < 0.5$**

Nomographs adapted from material furnished by Kaiser Aluminum and Chemical Corporation

Duplication of this nomograph may distort scale

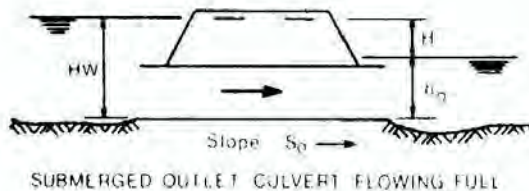


# CHART 47



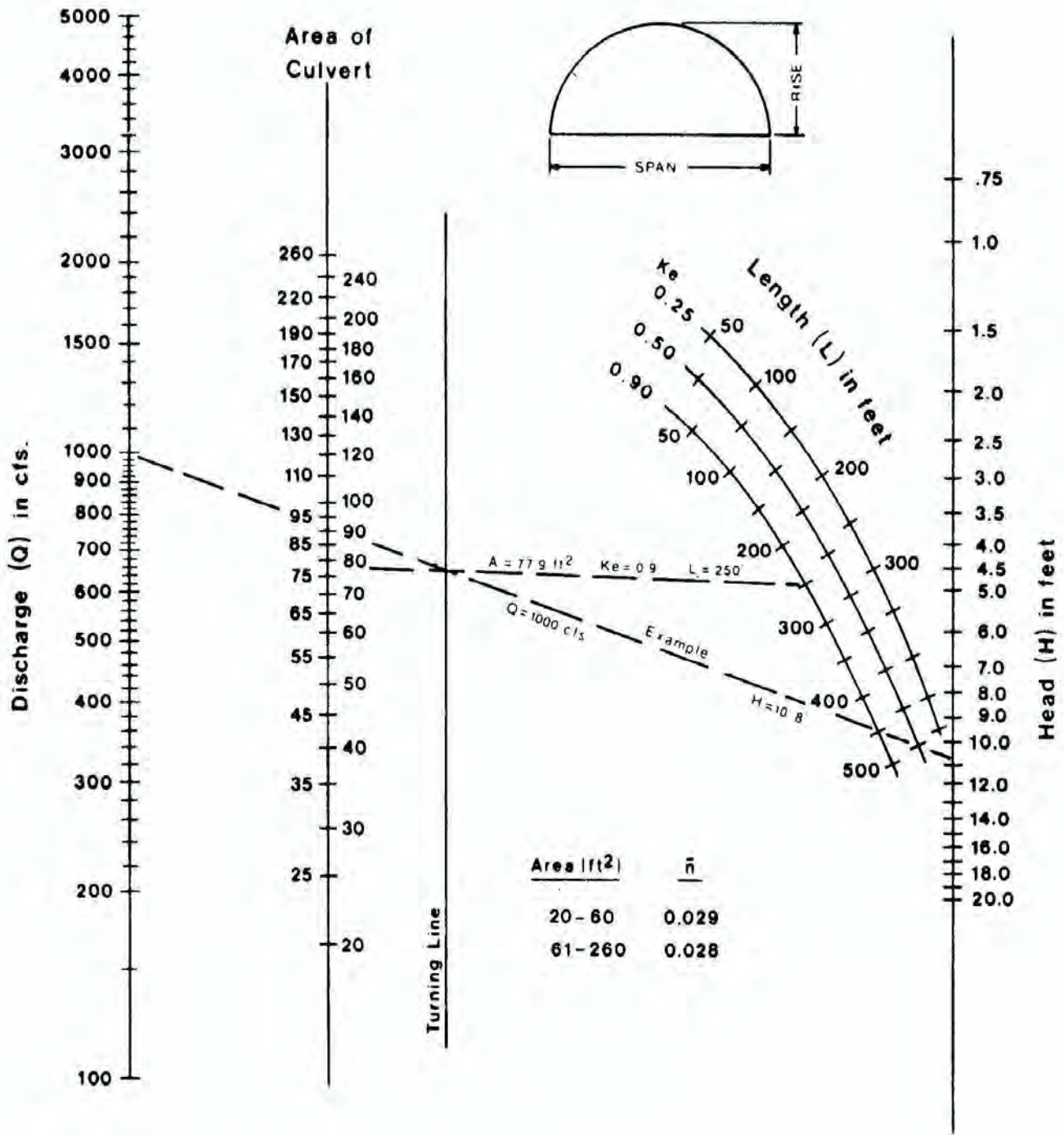
| Area (ft <sup>2</sup> ) | $\bar{n}$ |
|-------------------------|-----------|
| 20-30                   | 0.026     |
| 31-150                  | 0.025     |
| 151-360                 | 0.024     |

**HEAD FOR  
C.M. ARCH CULVERTS  
FLOWING FULL  
CONCRETE BOTTOM  
 $0.5 \leq \text{RISE} / \text{SPAN}$**

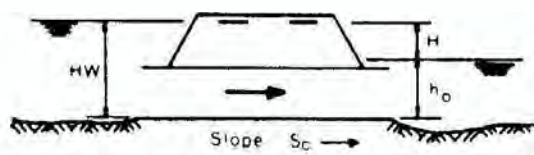


Nomographs adapted from material furnished by Kaiser Aluminum and Chemical Corporation

# CHART 48



| Area (ft <sup>2</sup> ) | $\bar{n}$ |
|-------------------------|-----------|
| 20 - 60                 | 0.029     |
| 61 - 260                | 0.028     |



SUBMERGED OUTLET CULVERT FLOWING FULL

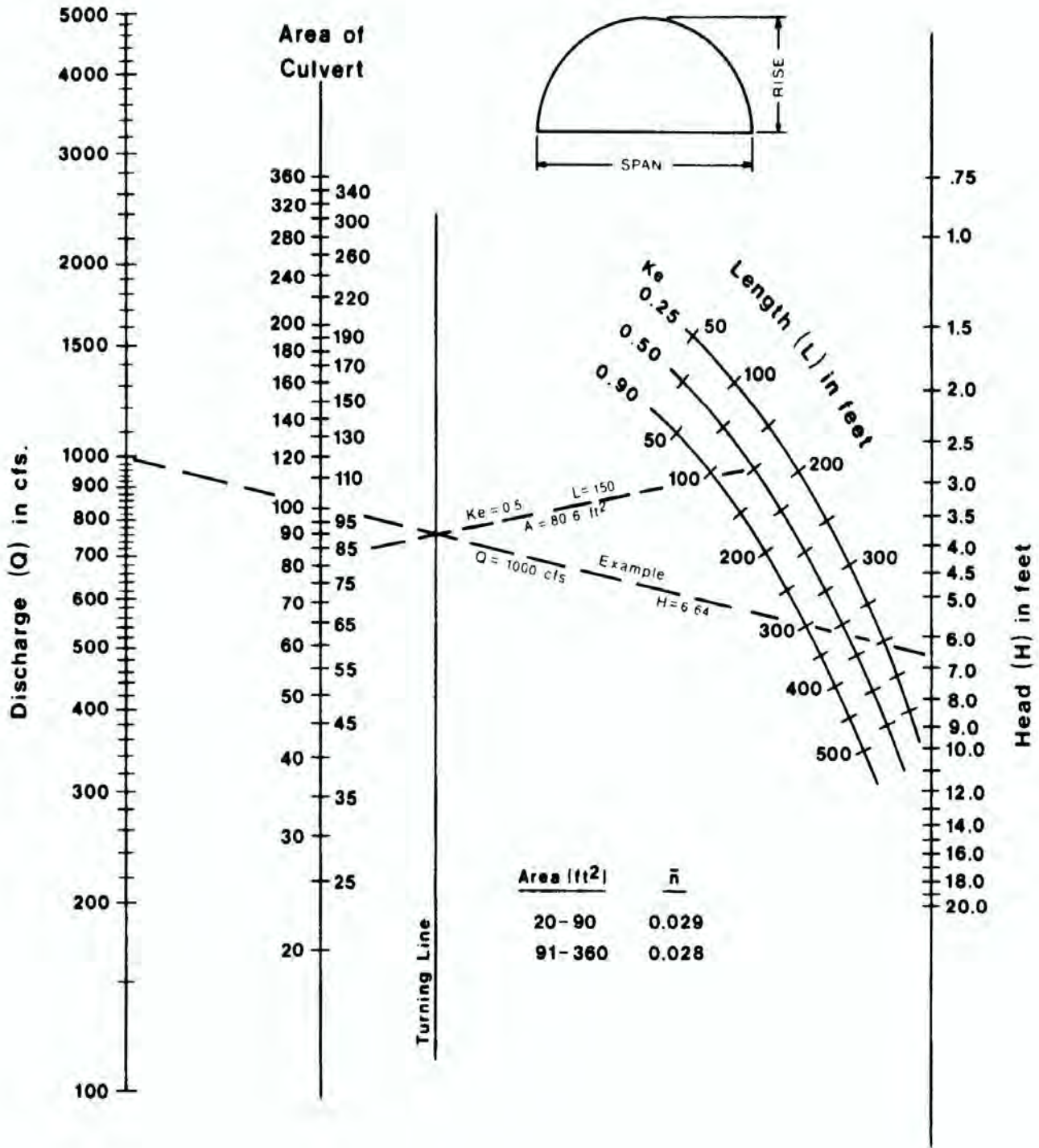
**HEAD FOR  
C.M. ARCH CULVERTS  
FLOWING FULL  
EARTH BOTTOM ( $n_b = 0.022$ )  
 $0.3 \leq \text{RISE} / \text{SPAN} < 0.4$**

Nomographs adapted from material furnished by Kaiser Aluminum and Chemical Corporation

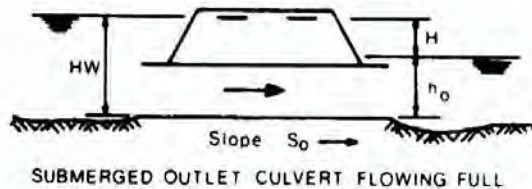
Duplication of this nomograph may distort scale



# CHART 49



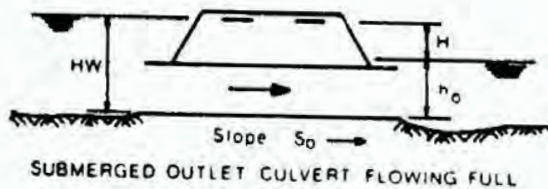
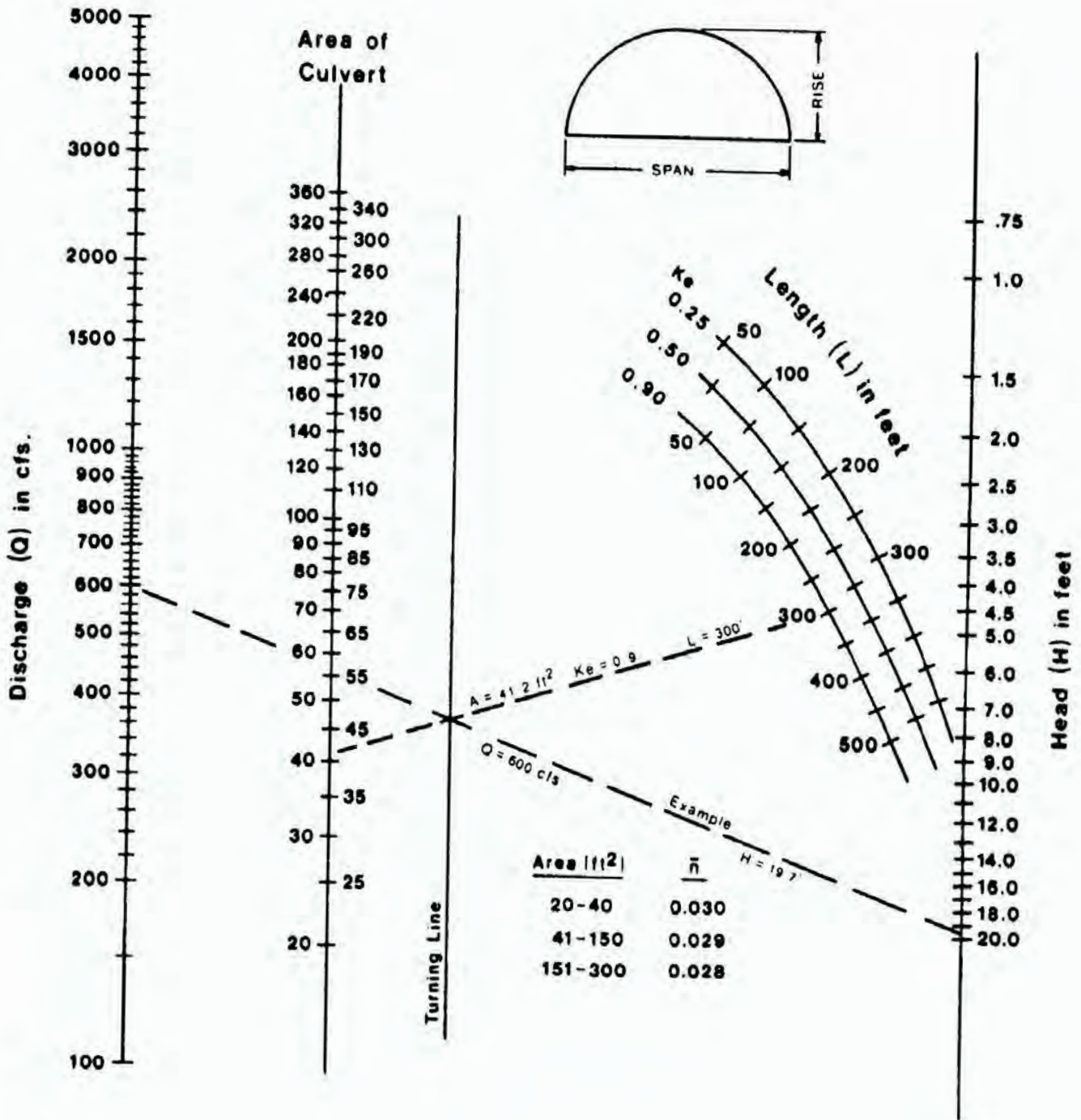
| Area (ft <sup>2</sup> ) | $\bar{n}$ |
|-------------------------|-----------|
| 20-90                   | 0.029     |
| 91-360                  | 0.028     |



**HEAD FOR  
C.M. ARCH CULVERTS  
FLOWING FULL  
EARTH BOTTOM ( $n_b = 0.022$ )  
 $0.4 \leq \text{RISE} / \text{SPAN} < 0.5$**

Nomographs adapted from material furnished by Kaiser Aluminum and Chemical Corporation

# CHART 50



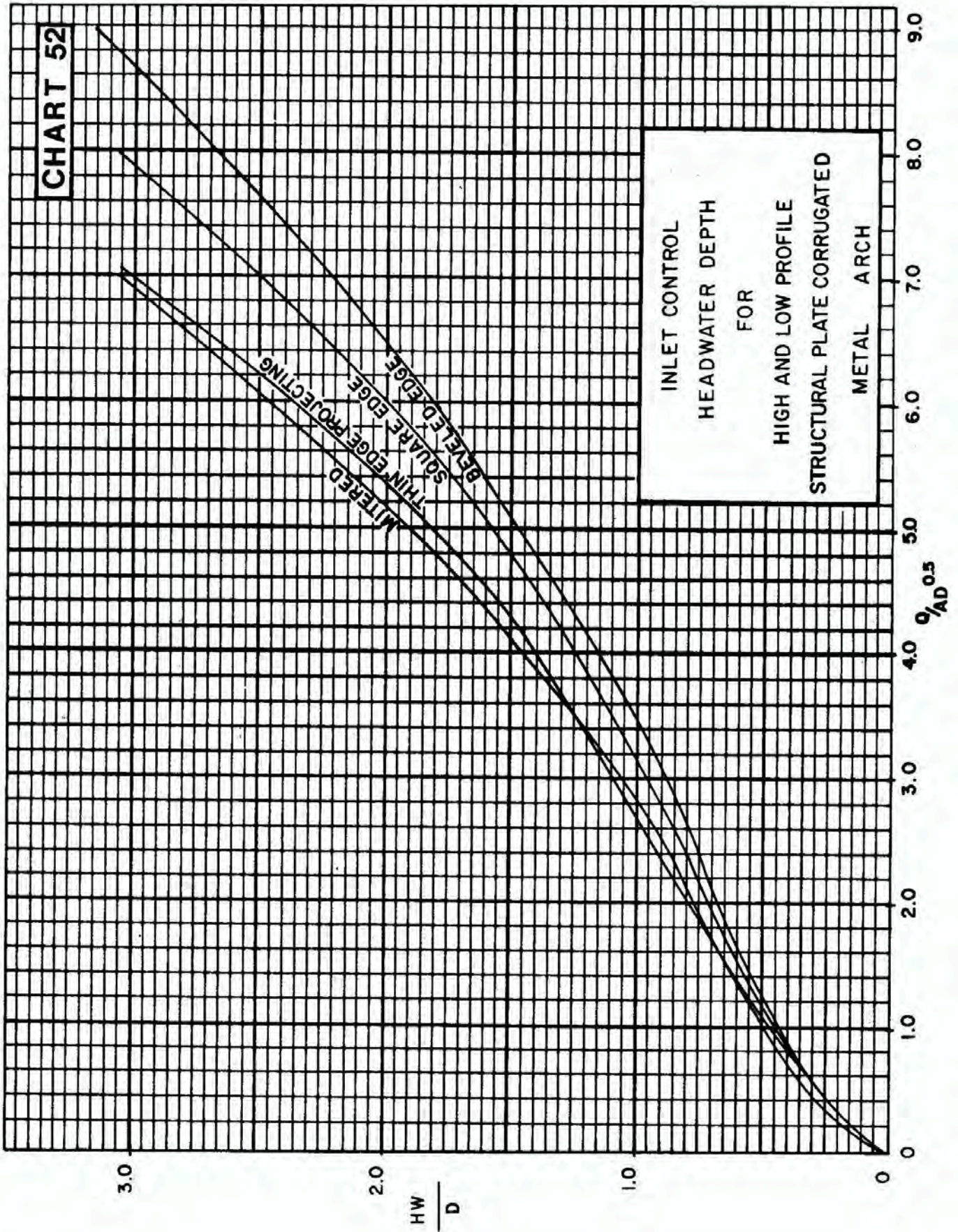
**HEAD FOR  
C.M. ARCH CULVERTS  
FLOWING FULL  
EARTH BOTTOM ( $n_b = 0.022$ )  
 $0.5 \leq \text{RISE} / \text{SPAN}$**

Nomographs adapted from material furnished by  
Kaiser Aluminium and Chemical Corporation

Duplication of this nomograph may distort scale

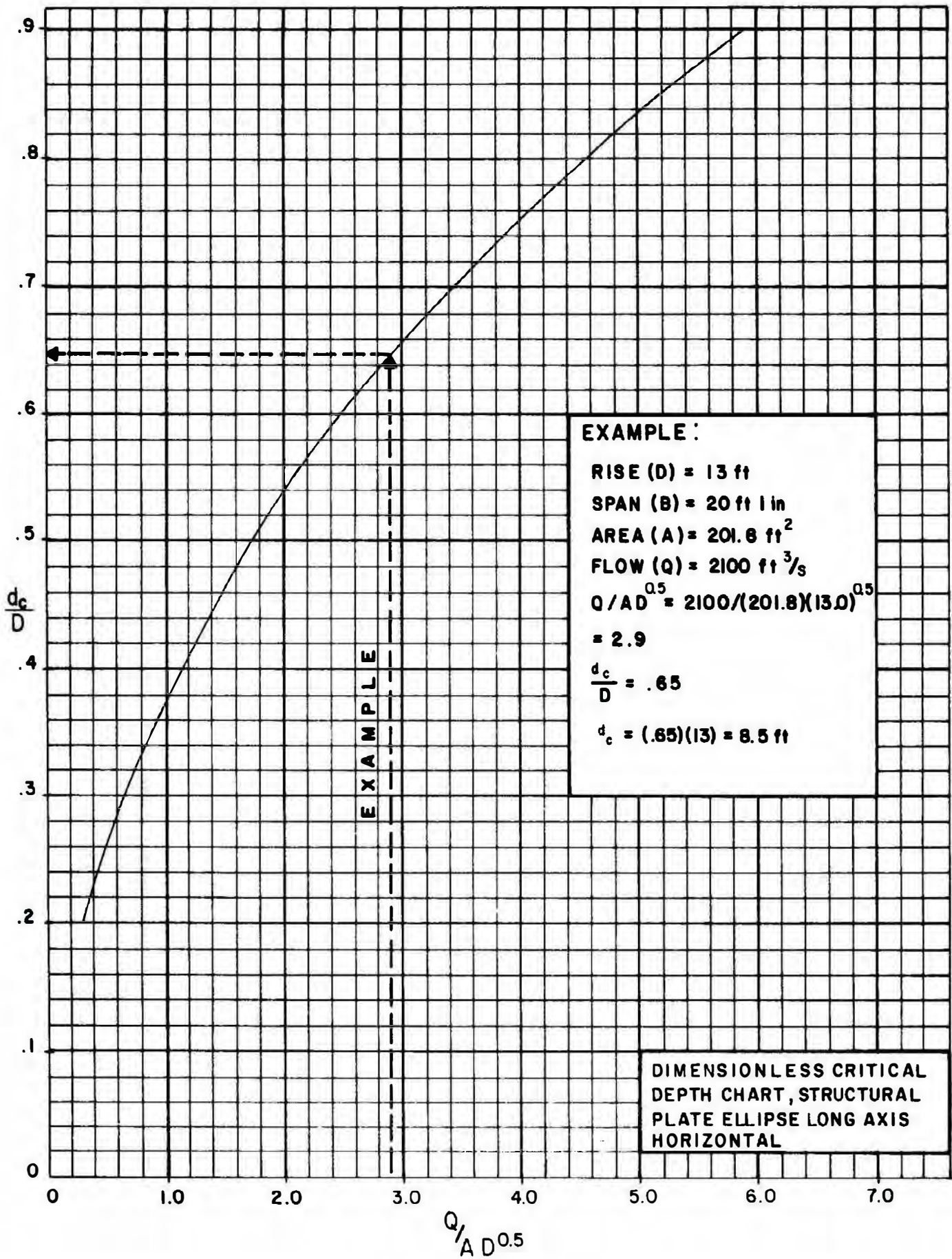


CHART 51  
(English Units)





# CHART 52 (English Units)



**EXAMPLE :**

RISE (D) = 13 ft  
 SPAN (B) = 20 ft | in  
 AREA (A) = 201.8 ft<sup>2</sup>  
 FLOW (Q) = 2100 ft<sup>3</sup>/s  
 $Q/AD^{0.5} = 2100/(201.8)(13.0)^{0.5}$   
 = 2.9

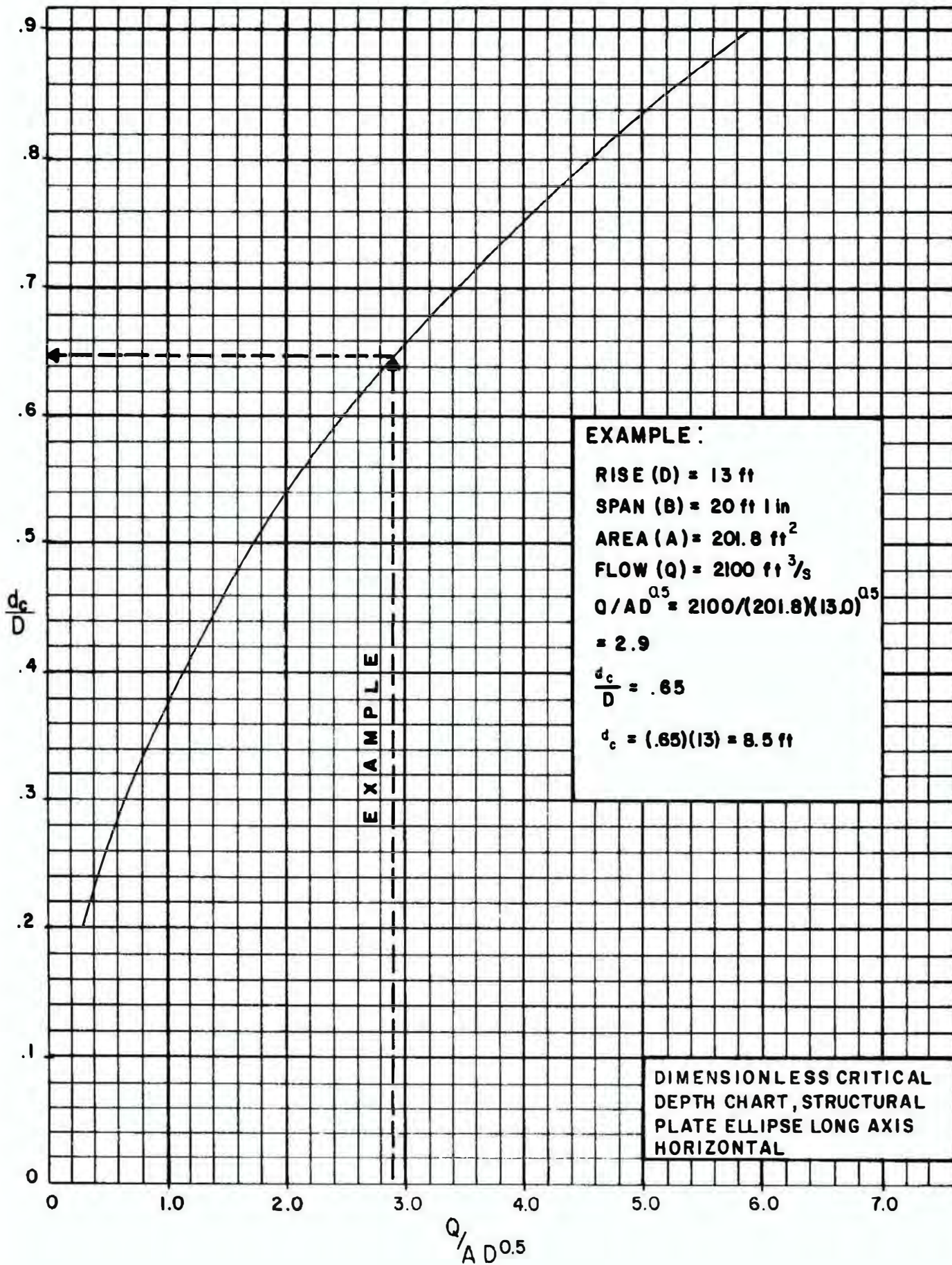
$\frac{d_c}{D} = .65$

$d_c = (.65)(13) = 8.5 \text{ ft}$

DIMENSIONLESS CRITICAL  
 DEPTH CHART, STRUCTURAL  
 PLATE ELLIPSE LONG AXIS  
 HORIZONTAL



# CHART 53



**EXAMPLE :**

RISE (D) = 13 ft  
 SPAN (B) = 20 ft 1 in  
 AREA (A) = 201.8 ft<sup>2</sup>  
 FLOW (Q) = 2100 ft<sup>3</sup>/s  
 $Q/AD^{0.5} = 2100/(201.8)(13.0)^{0.5}$   
 = 2.9

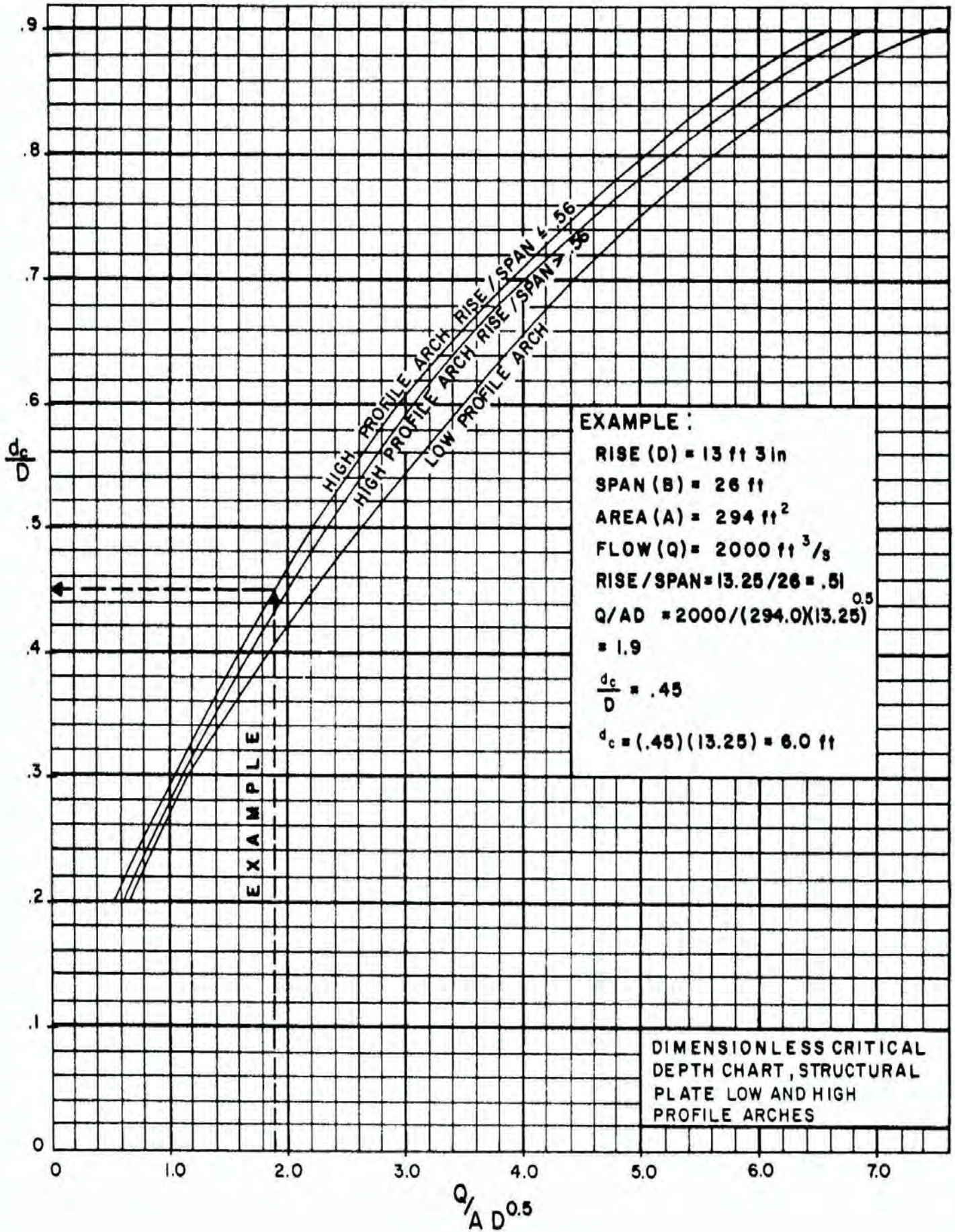
$\frac{d_c}{D} = .65$

$d_c = (.65)(13) = 8.5 \text{ ft}$

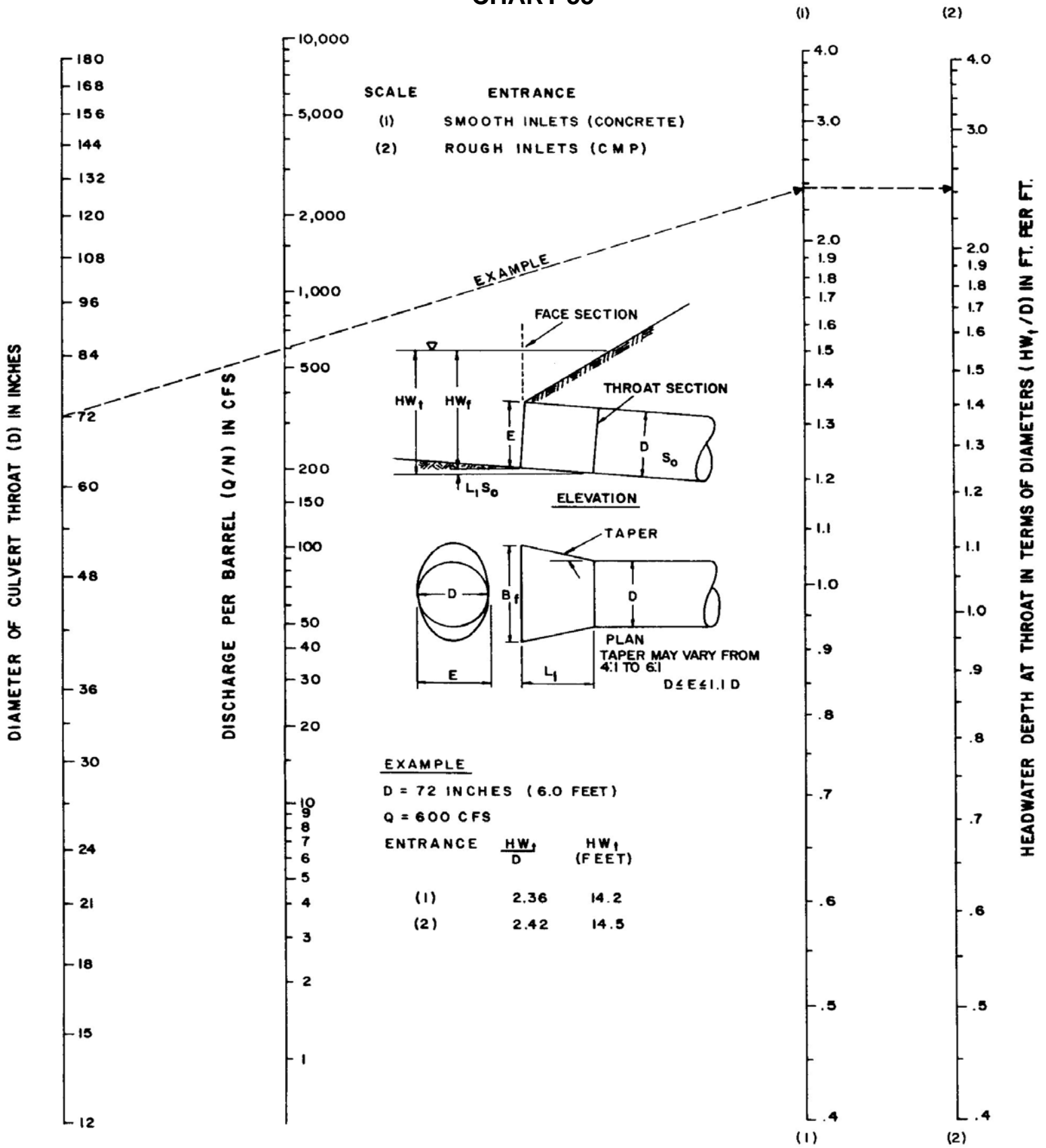
DIMENSIONLESS CRITICAL DEPTH CHART, STRUCTURAL PLATE ELLIPSE LONG AXIS HORIZONTAL



# CHART 54



# CHART 55



**EXAMPLE**

D = 72 INCHES ( 6.0 FEET )

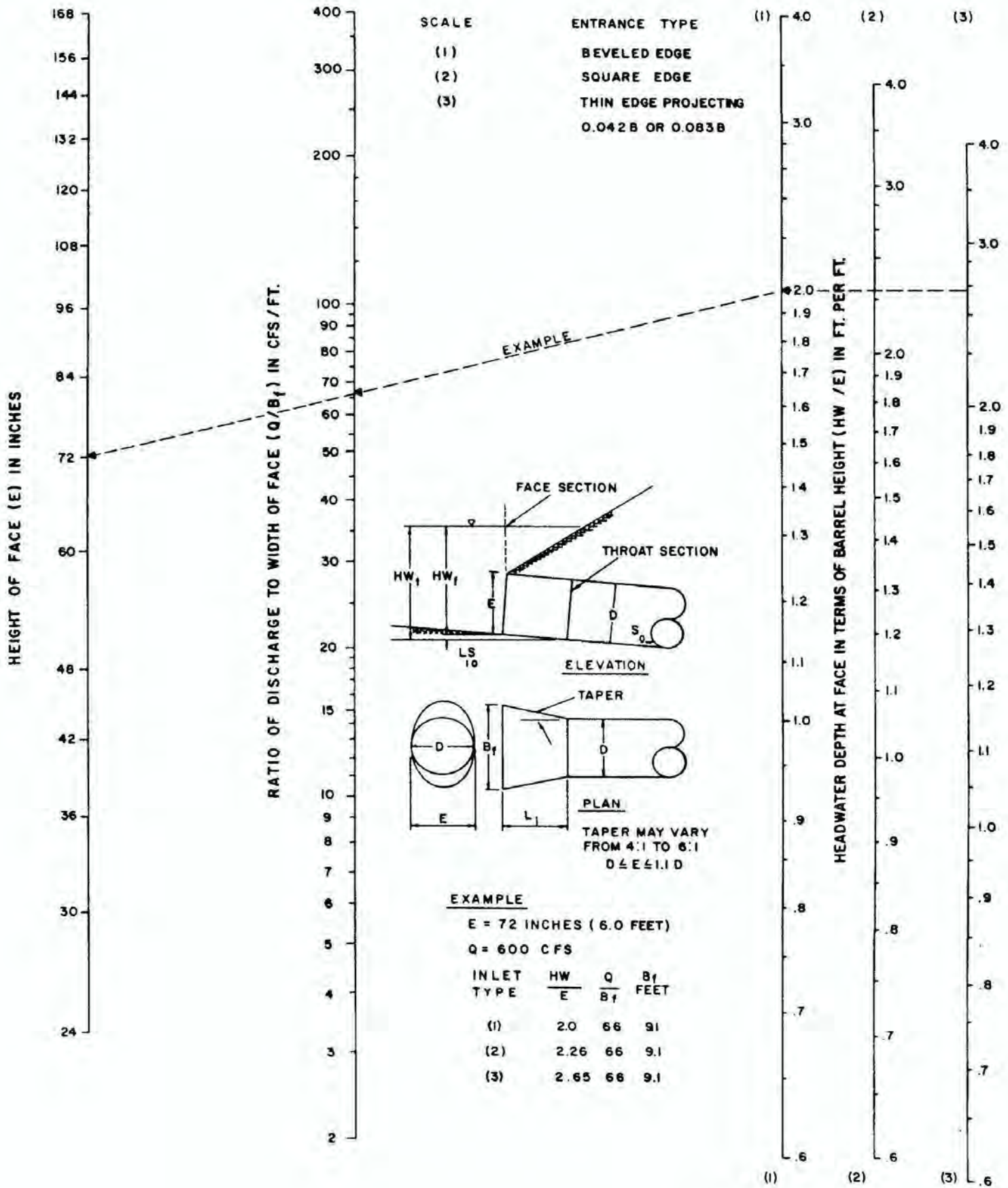
Q = 600 CFS

| ENTRANCE | $\frac{HW_1}{D}$ | HW <sub>1</sub> (FEET) |
|----------|------------------|------------------------|
| (1)      | 2.36             | 14.2                   |
| (2)      | 2.42             | 14.5                   |

**THROAT CONTROL FOR SIDE-TAPERED INLETS TO PIPE CULVERT (CIRCULAR SECTION ONLY)**



# CHART 56



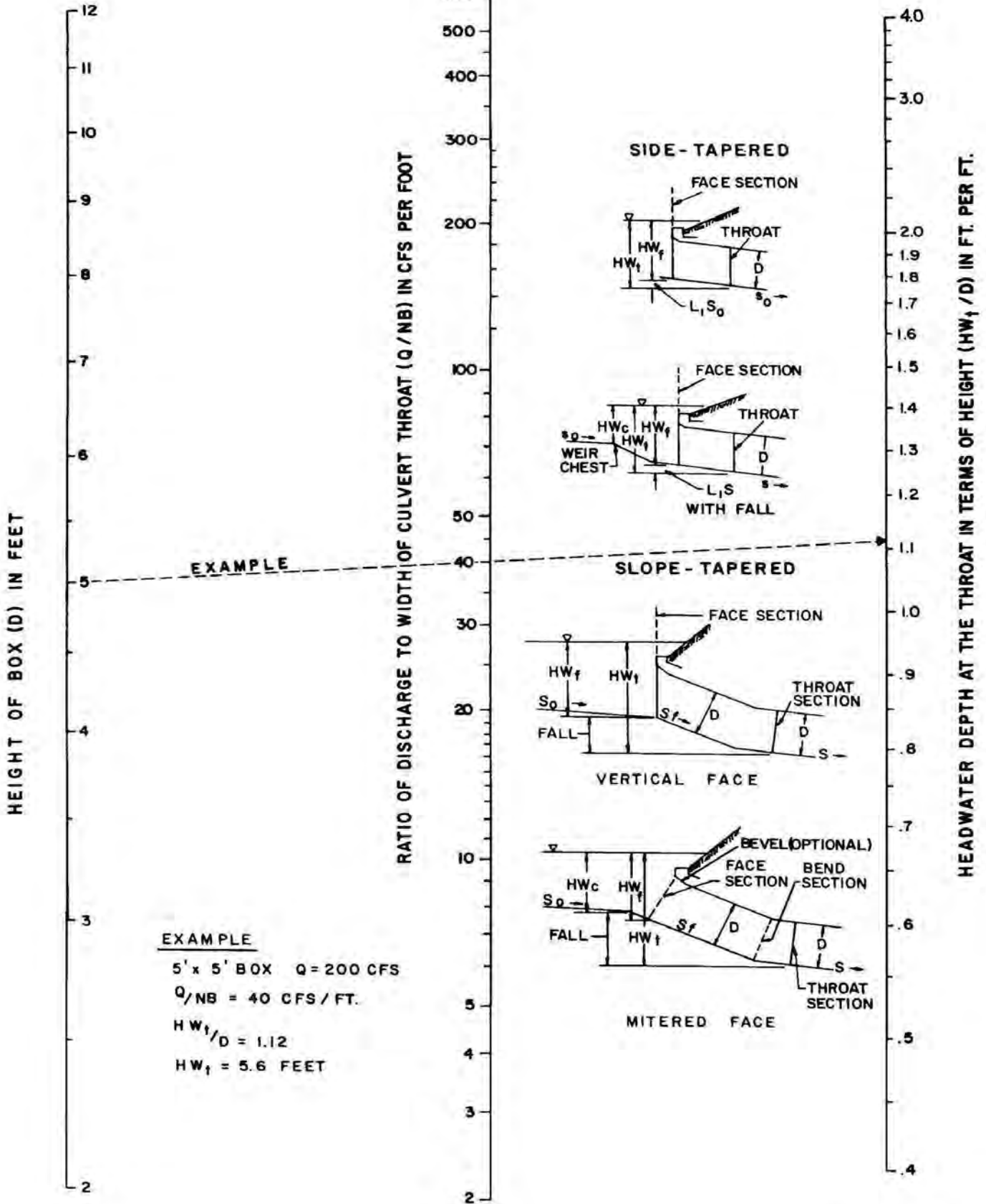
**EXAMPLE**

E = 72 INCHES (6.0 FEET)  
 Q = 600 CFS

| INLET TYPE | HW / E | Q / B <sub>f</sub> | B <sub>f</sub> FEET |
|------------|--------|--------------------|---------------------|
| (1)        | 2.0    | 66                 | 9.1                 |
| (2)        | 2.26   | 66                 | 9.1                 |
| (3)        | 2.65   | 66                 | 9.1                 |

**FACE CONTROL FOR SIDE-TAPERED INLETS TO PIPE CULVERTS (NON-RECTANGULAR SECTIONS ONLY)**

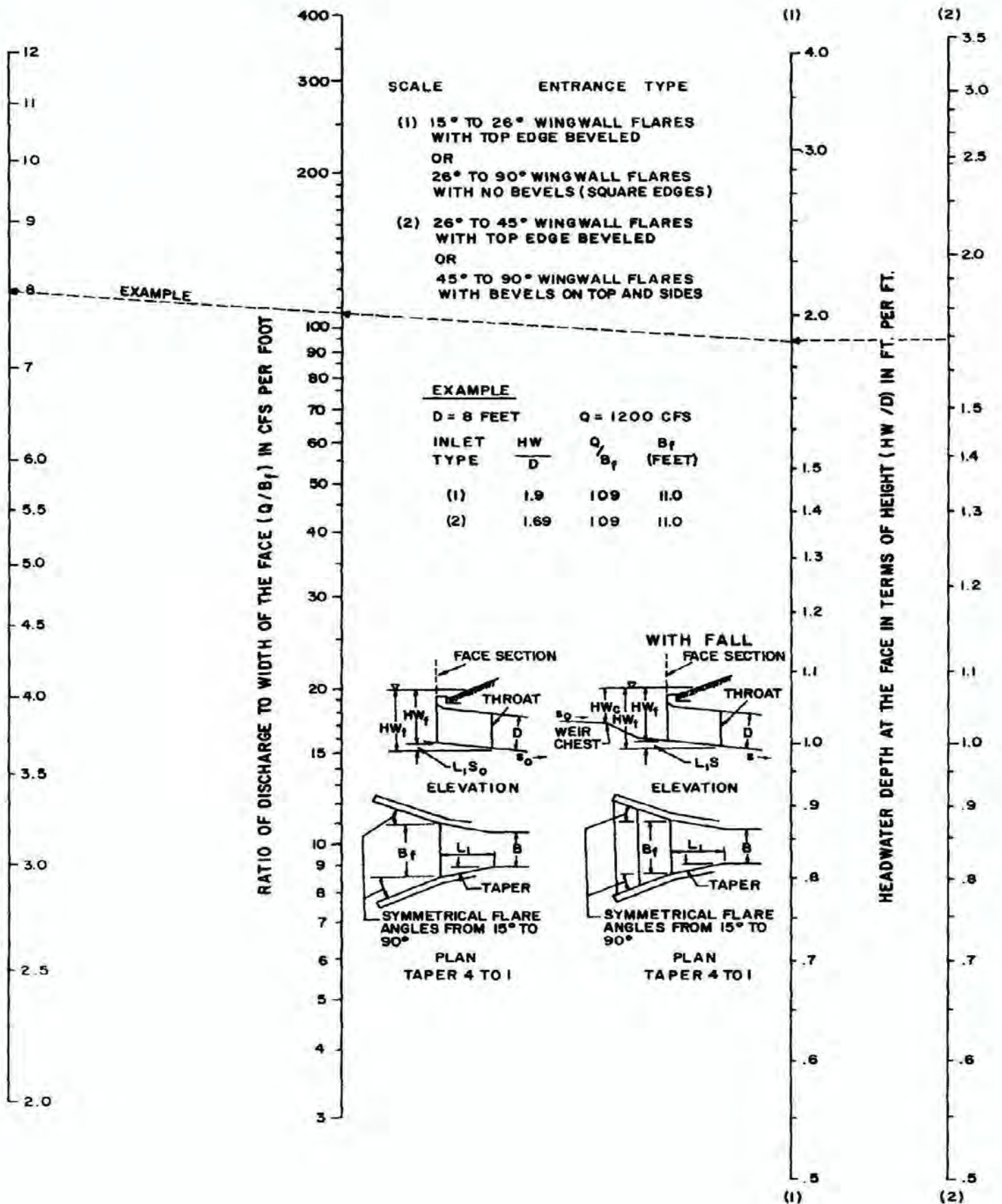
# CHART 57



**EXAMPLE**  
 5' x 5' BOX Q = 200 CFS  
 Q/NB = 40 CFS / FT.  
 $HW_t/D = 1.12$   
 $HW_t = 5.6$  FEET

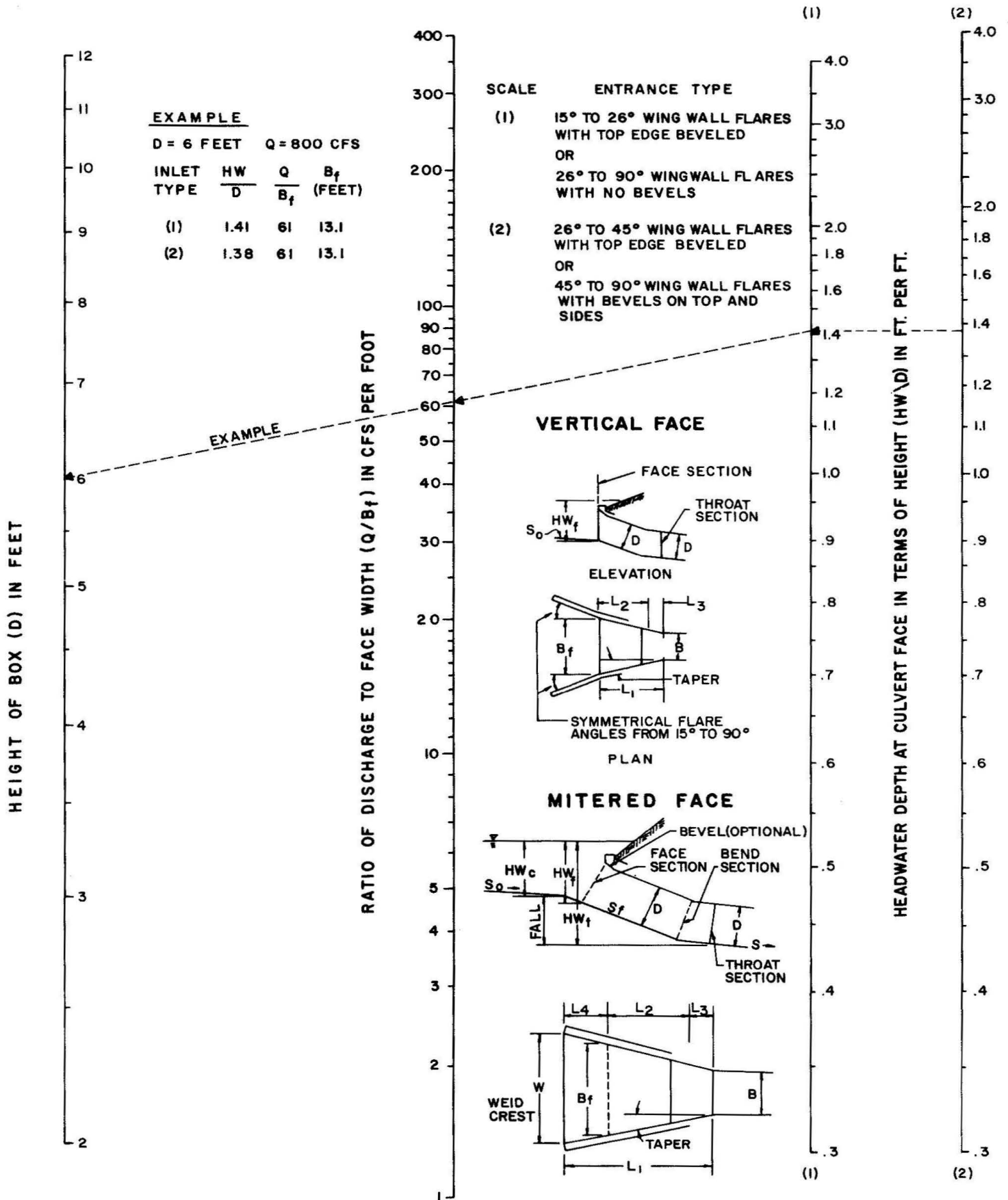
**THROAT CONTROL FOR BOX CULVERTS WITH TAPERED INLETS**

# CHART 58



**FACE CONTROL FOR BOX CULVERTS WITH SIDE TAPERED INLETS**

# CHART 59



FACE CONTROL FOR BOX CULVERTS WITH SLOPE TAPERED INLETS